

文件名称 File Name	文件编号 DOC NO.	客户代码 Code	版本 Version	日期 Date	产品类别 Product category	页码
产品规格书	FUXY/SPC-00340		2.0	2024/12/03	聚合物锂电池	2/15

SPECIFICATION AMENDMENT RECORDS (规格变更记录)

Edition 版本	Description 描述	Date 日期	Approved 审核
1.0	New	2024/12/03	

文件名称 File Name	文件编号 DOC NO.	客户代码 Code	版本 Version	日期 Date	产品类别 Product category	页码
产品规格书	FUXY/SPC-00340		2.0	2024/12/03	聚合物锂电池	3/15

Content

目录

1. Scope	4
适用范围	
2. Model: FUXY601525	4
编码规则	
3. Dimensions of cell	4
电芯尺寸	
4. Specification battery pack	5
电池规格	
5. Specification of cell	6
电芯规格	
6. Battery Cell Performance Criteria	7
电池性能检查及测试	
7. Handling Instructions	9
电池使用指南	
8. Notice for Designing Battery Pack	11
电池组装设计注意事项	
9. Required Protection Functions	12
保护板功能要求	
10. Guarantee Period of Quality	14
质量保证期	
11. Storing the Batteries	14
电池的存放	
12. Liability	14
产品责任	
13. Others	15
其他	

文件名称 File Name	文件编号 DOC NO.	客户代码 Code	版本 Version	日期 Date	产品类别 Product category	页码
产品规格书	FUXY/SPC-00340		2.0	2024/12/03	聚合物锂电池	4/15

1. Apply for Scope 适用范围

This specification describes the function of rechargeable polymer lithium battery that made in Shenzhen Fuxinyuan Energy Technology Co., Ltd.

本规格说明书描述了深圳市福新能源科技有限公司生产的可充电聚合物锂电池产品性能指标。

2. Model: FUXY601525

电池规格: FUXY601525

3. Dimensions of cell

电芯尺寸

T: $\leq 6.2\text{mm}$ * W: $\leq 15.5\text{mm}$ * L: $\leq 25.8\text{mm}$

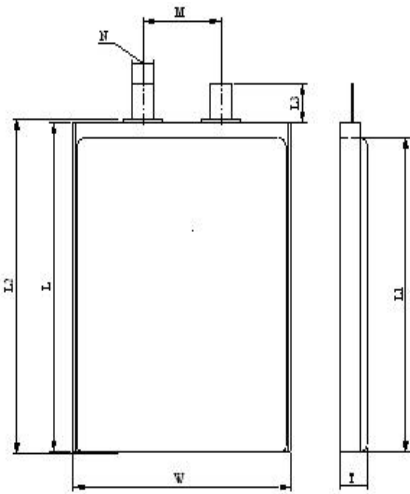

文件名称 File Name	文件编号 DOC NO.	客户代码 Code	版本 Version	日期 Date	产品类别 Product category	页码
产品规格书	FUXY/SPC-00340		2.0	2024/12/03	聚合物锂电池	5/15

4. Specification battery pack 电池规格

	Item	Specifications	Comments
4.1	Capacity (容量)	200mAh	0.2C Discharge(0.2C 放电)
4.2	Impedance (内阻)	$\leq 250\text{m}\Omega$	
4.3	Dimensions (mm) (尺寸)	≤ 6.2 (T) * 15.5 (W) * 27.5 (mm)	
4.4	Weight (g) (重量)	约 4g	
4.5	Max. charge voltage (最大充电电压)	4.2V	
4.6	Max. charge current (最大充电电流)	1.0CmA	
4.7	Discharge cut-off voltage (放电截止电压)	2.45V	
4.8	Max discharge current (最大放电电流)	1.0CmA	
4.9	Charge temperature (充电温度)	0°C ~ +45°C	
4.10	Discharge temperature (放电温度)	-20°C ~ +60°C	
4.11	Storage temperature (储存温度)	-20°C ~ +35°C	
4.12	Storage humidity (储存湿度)	< 85%	

文件名称 File Name	文件编号 DOC NO.	客户代码 Code	版本 Version	日期 Date	产品类别 Product category	页码
产品规格书	FUXY/SPC-00340		2.0	2024/12/03	聚合物锂电池	6/15

5. Specification of cell

电芯规格

NO.	Items	Specifications
1	Charge voltage 充电电压	4.2V
2	Nominal voltage 标称电压	3.7V
3	Nominal capacity 标称容量	200mAh 0.2C Discharge(0.2C 放电)
4	Charge current 充电电流	Standard Charging: 0.5C 标准充电: 0.5C Rapid charge: 1.0C 快速充电: 1.0C
5	Standard Charging method 标准充电方法	0.5C CC (constant current) charge to 4.2V, then CV(constant voltage 4.2V) charge till charge current decline to $\leq 0.02C$ 0.5C CC (恒流) 充电至 4.2V, 再 CV (恒压 4.2V) 充电直至充电电流 $\leq 0.02C$
6	Charging time 充电时间	Standard Charging: 5.0hours(Ref.) 标准充电: 5.0 小时 (参考值) Rapid charge: 2hours(Ref.) 快速充电: 2 小时 (参考值)
7	Max.charge current 最大充电电流	1.0C
8	Max.discharge current 最大放电电流	1.0C
9	Discharge cut-off voltage 放电截止电压	3.0V
10	Operating temperature 工作温度	Charging: 0°C~45°C 充电: 0°C~45°C Discharging: -20°C~60°C 放电: -20°C~60°C
11	Storage temperature 储存温度	-10°C~+35°C
12	Cell Weight 电芯重量	Approx: 3.7g 约: 3.7g

文件名称 File Name	文件编号 DOC NO.	客户代码 Code	版本 Version	日期 Date	产品类别 Product category	页码
产品规格书	FUXY/SPC-00340		2.0	2024/12/03	聚合物锂电池	7/15

6. Battery Cell Performance Criteria

电芯性能检查及测试

6.1 Electrical characteristics 充放电性能

NO.	Items	Test Method and Condition	Criteria
1	Standard Charge 标准充电	Charging the cell initially with constant current at 0.2C and then with constant voltage at 4.2V till charge current declines to 0.02C 先用 0.2C 恒流充电至 4.2V，再恒压 4.2V 充电直至充电电流 $\leq 0.02C$	
2	Rated Capacity 初始容量	The capacity means the discharge capacity of the cell, which is measured with discharge current of 0.2C with 3.0V cut-off voltage after standard charge. 该容量是指标准充电后，0.2C 放电至 3.0V 截止电压所放出的容量。	$\geq 200\text{mAh}$
3	Cycle Life 循环寿命	Test condition: Charge: 0.2C to 4.2V Discharge: 0.2 C to 3.0V 80% or more of 1 st cycle capacity at 0.2C discharge of Operation 测试条件: 充电: 0.2C 充电到 4.2V 放电: 0.2C 放电到 3.0V 当放电容量降至初始容量的 80% 时，所完成的循环次数定义为该电芯的循环寿命	≥ 300 次
4	Self-discharge 自放电	After charging standard, in $20 \pm 5^\circ\text{C}$ conditions storage 28 days, again with 0.2 C discharge to 3.0 V emit capacity. 标准充电后，在 $20 \pm 5^\circ\text{C}$ 条件下贮存 28 天，再以 0.2C 放电至 3.0V 所放出的容量。	Residual capacity >90 % 余容量 >90%
5	Initial impedance of cell 电池初始内阻	Internal resistance measured at AC 1KHz after 50% charge 半充状态下，测量其 AC 1KHz 下的交流阻抗	$\leq 80\text{m}\Omega$
6	Temperature Characteristics 温度特性	1. According to item 5.5, at $25 \pm 5^\circ\text{C}$. 2. Capacity comparison at each temperature, measured with constant discharge current 0.2C with 3.0V cut-off. Percentage as an index of the capacity compared with 100% at 25°C 1. 在 $25 \pm 5^\circ\text{C}$ 条件下，用 5.5 方法将电芯充电。 2. 在不同温度条件下，用 0.2C 的电流恒流放电至截止电压 3.0V。以 25°C 时放电容量为基准计算百分比。	-20°C : $\geq 50\%$ 25°C : 100% 50°C : $\geq 85\%$

文件名称 File Name	文件编号 DOC NO.	客户代码 Code	版本 Version	日期 Date	产品类别 Product category	页码
产品规格书	FUXY/SPC-00340		2.0	2024/12/03	聚合物锂电池	8/15

6.2 Mechanical characteristics

机械特性

NO.	Items	Test Method and Condition	Criteria
1	Vibration Test 振动测试	After standard charging, fixed the cell to vibration table and subjected to vibration cycling that the frequency is to be varied at the rate of 1Hz per minute between 10Hz and 55Hz, the excursion of the vibration is 1.6mm.The cell shall be vibrated for 30 minutes per axis of XYZ axes. 将标准充电后的电池固定在振动台上，沿 X、Y、Z 三个方向各振动 30 分钟，振幅 1.6 mm，振动频率为 10Hz~55Hz，每分钟变化为 1Hz。	No leakage 无泄漏 No fire 不起火
2	Drop Test 跌落测试	The cell is to be dropped from a height of meter twice onto concrete ground. 将标准充电后的电芯从 1 米高度跌落至混凝土地面 2 次	No fire, no leakage. 无起火、无泄漏

6.3 Visual inspection

外观检查

There shall be no such defect as scratch, flaw, crack, and leakage, which may adversely affect commercial value of the cell.

不允许有任何影响电芯性能的外观缺陷，诸如裂纹、裂缝、泄漏等。

6.4 Standard environmental test condition

标准测试环境

Unless otherwise specified, all tests stated in this Product Specification are conducted at below condition:

Temperature: $25 \pm 5^{\circ}\text{C}$

Humidity: $\leq 75\%RH$

除非特别说明，本标准中所有测试均在以下环境条件下进行：

温度： $25 \pm 5^{\circ}\text{C}$

湿度： $\leq 75\%RH$

文件名称 File Name	文件编号 DOC NO.	客户代码 Code	版本 Version	日期 Date	产品类别 Product category	页码
产品规格书	FUXY/SPC-00340		2.0	2024/12/03	聚合物锂电池	9/15

7. Handling Instructions

电池使用指南

Read and observe the following warnings and precautions to ensure correct and safe of Li-ion batteries. We are not responsible for any problems arising from any violation of the following matters need attention.

认真阅读下面的注意事项，确保正确使用锂离子电池。我司对违反下述注意事项而产生的任何问题不予负责。

Danger!

危险!

Failure to observe the following precautions may result in battery leakage, overheating, explosion or fire.

不仔细阅读下述事项可能导致电池泄露、发热、爆炸或起火。

- Do not immerse the battery in water or allow it to get wet.
勿将电池投入水中或将其弄湿。
- Do not use or store the battery near sources of heat such as a fire or heater.
勿在热源（如火或加热器）附件使用或贮存电池。
- Do not use any chargers other than those produced by qualified charger manufacturer.
请使用质量合格的充电器。
- Do not reverse the positive (+) and negative (-) terminals.
勿将正负极接反。
- Do not connect the battery directly to wall outlets or car cigarette-lighter sockets.
勿将电池直接连接到墙上插座或车载点烟式插座上。
- Do not put the battery into fire or apply direct heat to it.
勿将电池投入火中或给电池加热。
- Do not short-circuit the battery by connecting wires or other metal objects to the positive (+) and negative (-) terminals.
禁止用导线或其它金属物体将电池正负极短路。
- Do not carry or put the battery together with necklaces, hairpins or other metal objections.
禁止将电池和项链、发夹或其它金属物品放置在一起。
- Do not strike, throw or subject the battery near a fire or in extremely hot conditions.
禁止将电池投放到较热的容器里。

Warning!

警告!

Failure to observe the following precautions may result in battery leakage, overheating, explosion or fire.

不仔细阅读下述事项可能导致电池泄露、发热、爆炸或起火。

- Do not place the battery in a microwave oven or pressurized container.
禁止将电池置入微波炉或压力容器中。
- Do not use the battery in combination with primary batteries (such as dry-cell batteries) or batteries of different capacity, type or brand.
禁止与一次性电池（如干电池）或不同容量、型号、品种的电池组合使用。
- Do not using the battery if it gives off an odor, generates heat, deformation or anything unusual. If the abnormal battery is in use or being recharged, removed it from appliance or charger immediately and stop using.
如果电池发出异味、发热、变形或出现其它异常情况时，不得使用电池。如果异常的电池正在使用或者充电，请立即从电器或从充电器上取下来并停止使用电池。
- Do not pierce the battery casing with a nail or other sharp object, break it open with a hammer, or step on it.

文件名称 File Name	文件编号 DOC NO.	客户代码 Code	版本 Version	日期 Date	产品类别 Product category	页码
产品规格书	FUXY/SPC-00340		2.0	2024/12/03	聚合物锂电池	10/15

禁止用钉子或其它尖锐物体刺穿电池壳体，禁止锤击或脚踏电池。

- Do not directly solder the battery positive (+) and negative (-) terminals.

禁止直接焊接电池正负极。

- Do not attempt to disassemble or modify the battery in any way.

禁止用任何方式分解电池。

- Keep the batteries out of the reach of children. If a child somehow swallow a battery, seek medical attention immediately.

电池应放在小孩接触不到的地方，如果小孩不小心吞咽电池，应立即寻求医疗救助。

If the battery leaks or emits an odor, immediately remove it from the proximity of any exposed flame. The leaking electrolyte can ignite and cause a fire or explosion.

如果电池泄露或者发出异味，应立即将其从明火处移开。泄露的电解液可能引起火灾或爆炸。

If the battery leaks and electrolyte get in your eyes, do not rub them. Instead, rinse them with clean running water immediately and seek medical attention. If left as is, electrolyte can cause eye injury.

如果电池漏液后电解液进入眼睛，不要擦眼睛，应立即用清水冲洗并寻求医疗救助。如不及时处理，眼睛将会受到伤害。

Caution!

注意!

Do not use or store the battery where is exposed to extremely hot, such as under window of a car in direct sunlight in a hot day. Otherwise, the battery may be overheated. This can also reduce battery performance and shorten cycle life.

不要使用或贮存于极热环境中的电池，如在阳光直射或热天车内的电池。否则，电池会过热，同时会影响电池的性能、缩短电池的使用寿命。

The isolated measures are needed between battery (the bare AI layer at side and top sealing) and the PCB, and also between battery and electric equipment: especially avoid the AI layer in packing foil contact to cathode or anode (including electric equipment), otherwise this can cause battery leakage or swelling.

注意电芯（侧边和极耳封边包装膜断口位置裸露的铝层）与保护板，及电芯与电器之间采用绝缘结构措施：特别注意避免出现包装膜铝层与正负极（包括电器的带电部分）出现接触的隐患，否则可能造成电池漏液气胀。

Use the battery only under the following environmental conditions. Failure to do so can result in reduced performance or a shorten service life. Recharging the battery outside of these temperatures can cause the battery to overheat, explode or catch fire.

只能在下述条件下使用电池，否则将会降低电池的性能或缩短电池的使用寿命。在此温度范围外使用电池可能引起电池过热、爆炸或起火。

Operating environment 工作环境:

When charging the battery 电池充电温度: 10°C ~ +45°C

When discharging the battery 电池放电温度: 0°C ~ +55°C

When stored 存储温度: -10°C ~ +35°C

The voltage for a long time (≥ 6 months) storage shall be recharged 3.7V-3.9V range.

超过 6 个月请及时进行充放一周后补电到 3.7V 至 3.9V。

文件名称 File Name	文件编号 DOC NO.	客户代码 Code	版本 Version	日期 Date	产品类别 Product category	页码
产品规格书	FUXY/SPC-00340		2.0	2024/12/03	聚合物锂电池	11/15

In cases where children use the battery, instruct them on the contents of the user's guide and keep an eye on the to ensure that the battery is being used correctly.

当小孩使用电池时，需要按用户说明书的内容教他们，并密切注意他们确保正确使用电池。

If the battery leaks and electrolyte gets your skin or clothing, immediately rinse the affected area with clean running water. If left as is, the skin inflammation can occur.

如果电池漏液，电解液弄到皮肤或衣服上，立即用流动的清水冲洗受影响的区域，否则可能导致皮肤发炎。

For directions on batter installation and removal, read the instruction manual that accompanies the equipment in which the battery will be used.

阅读电池的装置说明书，正确进行电池的安装与拆卸。

If a device is not used for an extended period, the battery should be removed and stored in a cool, dry place. Otherwise, resting or reduced performance may occur.

如果设备长期不用，请将电池取出并放置在凉爽、干燥的地方，否则，电池可能生锈或者性能变差。

If the terminals of the battery are dirty, wipe them clean with dry cloth before use. Otherwise, solid electrical contact may not be charged with the equipment, and this can cause power outages or charging to fail.

如果电池的端子/正负极变脏，使用前请用干布擦干净，否则电池会接触不良，从而引起能量损耗或无法充电。

8. Notice for Designing Battery Pack

电池组装设计注意事项

8.1 Pack toughness

外壳坚韧度

Battery pack should have sufficient strength and the LIP cell inside should be protected from mechanical shocks.

电池外壳应该有足够的机械强度使聚合物电池免受机械撞击。

8.2 Cell fixing

电池的固定

The cell should be fixed to the battery pack by its large surface area.

No cell movement in the battery pack should be allowed.

电池最大面积的一面应该固定在外壳上，安装后电池不能有松动。

8.3 Inside design

外壳内部设计

No sharp edge components should be insides the pack containing the battery.

产品外壳内，安装电池的部位不应有锋锐边。

8.4 Assembling

装配

Shocks, high temperature, or contacts of sharp edge components should not be allowed in battery pack assembling process.

在电池装配过程中不允许撞击、高温或接触尖锐部分。

文件名称 File Name	文件编号 DOC NO.	客户代码 Code	版本 Version	日期 Date	产品类别 Product category	页码
产品规格书	FUXY/SPC-00340		2.0	2024/12/03	聚合物锂电池	12/15

9. Parameter of PCB

保护板参数

9.1 List of Parameter

保护板参数清单

符号	测试内容	检测标准值	测试实际值					判定条件
			1	2	3	4	5	
VOCTYP	过充电保护电压	4.275V+25mV/-50mV	4.265	4.270	4.265	4.275	4.260	
VDET1-1	有无0V充电功能	有0V充电功能						
VOCRTYP	过充电恢复电压	4.075±0.05V						
VODTYP	过放电保护电压	2.50±0.075V	2.542	2.542	2.497	2.485	2.513	
VODRTYP	过放电恢复电压	2.90±0.075V						
VRET2-1	有无休眠功能	有休眠功能						
VDET3	过放过流压差 (V/A)	0.14 ± 0.02V	3.05	3.11	3.07	3.01	2.98	
ICDC	最大持续放电电流 (A)	1-1.5A						
TOCTYP	充电保护延迟时间	80mS ± 30%						TA=25℃
TODTYP	放电保护延迟时间	40mS ± 30%						TA=25℃
TEDITYP	过充电流保护延迟时间	7.0mS ± 30%						TA=25℃
TVDET4	过放电流保护延迟时间	7.0mS ± 30%						TA=25℃
TSHORT	负载短路检测延时时间	80 ± 40μ S						TA=25℃
Istandy	自耗电流	I≤6.0uA	3.9	3.8	4.2	4.0	3.7	
RDS	PCB内阻	R≤60mΩ	37	35	37	40	42	

9.2 List of PCB BOM

主要原件清单

序号	物料代码	物料名称	规格	型号	单位	数量	厂商	备注
1	U1	控制 IC	VA7020	SOT-23-6	个	1	中星微	
2	U2	N-MOS管	8205A	SOT-23-6	个	1	鑫飞宏	
3	R1	贴片电阻	100Ω 5%	1/16W 0402	个	1	丽智	
4	R2	贴片电阻	1KΩ 5%	1/16W 0402	个	1	丽智	
5	C1	贴片电容	100nF 20%	50V 0402	个	1	丽智	
6	PCB	线路板	8.0*4.0*0.6mm		个	1	富士威	

文件名称 File Name	文件编号 DOC NO.	客户代码 Code	版本 Version	日期 Date	产品类别 Product category	页码
产品规格书	FUXY/SPC-00340		2.0	2024/12/03	聚合物锂电池	13/15

9.3 Dimension of PCB

保护板尺寸

顶层:

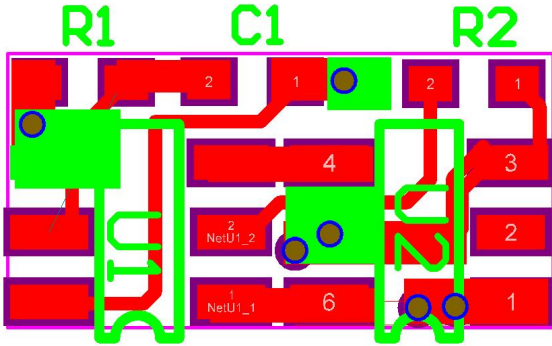

底层:

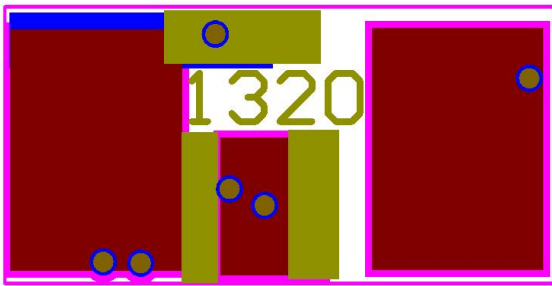

保护板尺寸: L8.4*W4.0±0.1mm

板厚度: 成品厚度 Max0.6mm

表面处理: PCB 喷无铅锡

注: 保护板的长度正负公差±0.15mm, 宽度正负公差±0.10mm, 厚度正公差 0.10mm

9.4 Circuit Diagram

原理图

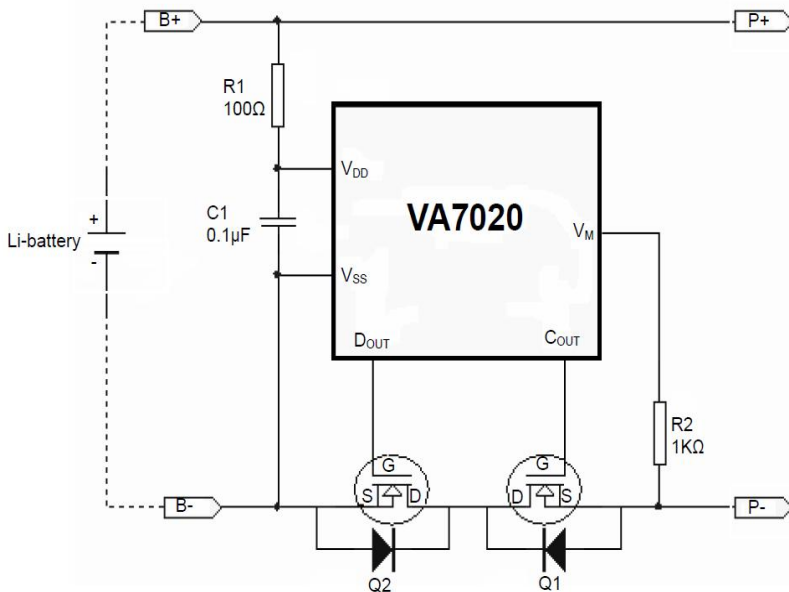

文件名称 File Name	文件编号 DOC NO.	客户代码 Code	版本 Version	日期 Date	产品类别 Product category	页码
产品规格书	FUXY/SPC-00340		2.0	2024/12/03	聚合物锂电池	14/15

9.5 PACK Battery External Dimension Drawing

电池尺寸示意图

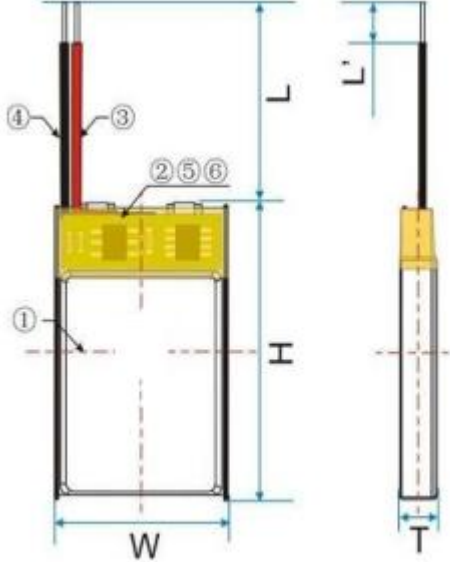
	<p>1. External Dimension: Thickness (T): Max. 6.2mm Width (W): Max. 15.5mm Height (H): Max. 27.5mm Wire long: L=30mm±5mm</p> <p>2. Material: ① Cell: FUXY601525 ② PCBA ③ Wire: Red(+) UL1571 30AWG ④ Wire: Black(-) UL1571 30AWG ⑤ Insulating Tape: 15mm ⑥ Insulating Tape: 6mm</p>
---	---

10. Guarantee Period of Quality

质量保证期

The period of warranty is one year from the date of shipment. Fuxinyuan guarantees to give a replacement in case of cells with defects proven due to manufacturing process instead of the customer abuse and misuse.

电池的保质期从出货之日算起为一年。如果证明电池的缺陷是在制造过程中形成的而不是由于用户滥用及错误使用造成，本公司负责更换电池。

11. Storing the Batteries

电池的存放

The batteries should be stored at room temperature, charged to about 30% to 50% of capacity.

We recommend that batteries be charged about once per half a year to prevent over discharge.

电池应当在室温下单独存放，应充到 30%至 50%的电量。

如长时间储存，建议每半年充一次电以防止电池过放电。

12. Liability

产品责任

Please use the rechargeable polymer lithium battery supplied by Fuxinyuan under the product specification.

It may cause fire or expansion if the batteries are used incorrect.

We will not guarantee the safety unless the batteries are used under the product specification.

请客户务必按照所提供的规格说明书和所附的注意事项来使用福新源公司生产的电池。

不正确地使用电池，可能会导致电池性能异常、着火或破裂现象。

对于客户在超出规格说明书以外的情况下使用电池，兄弟新能源公司不保证其使用的性能和安全性。

文件名称 File Name	文件编号 DOC NO.	客户代码 Code	版本 Version	日期 Date	产品类别 Product category	页码
产品规格书	FUXY/SPC-00340		2.0	2024/12/03	聚合物锂电池	15/15

13. Others

其它

13.1 Battery cells replacement

更换电池

The battery replacement shall be done only by either cells supplier or device supplier and never be done by the user. 更换电池应由电池生产商或设备供应商完成，用户不要自行更换。

13.2. Never disassemble the cells

不要拆卸电池

The disassembling may generate internal short circuit in the cell, which may cause gassing, firing, explosion, or other problems.

拆卸电池会发生电池内部短路，会引起起火、爆炸、有害气体或者其它问题。

13.3 Do not use abnormal battery

不要使用出现异常的电池

The cells might be damaged during shipping by shock. If any abnormal features of the cells are found such as damages in a plastic envelop of the cell, deformation of the cell package, smelling of an electrolyte, an electrolyte leakage and others, the cells shall never be used any more.

电池可能在出货途中碰撞而受损。如果发现电池有异常，例如包装损坏、电池包裹变形，有电解液的味道、发现漏液等等，不要再使用这些电池。

13.4 Storage Battery Properly

合理存放电池

Because batteries utilize a chemical reaction, battery performance will deteriorate over time even if stored for a long period of time without being used. In addition, if the various usage conditions such as charge, discharge, ambient temperature, etc. are not maintained within the specified ranges the life expectancy of the battery may be shortened or the device in which the battery is used may be damaged by electrolyte leakage. If the batteries cannot be charged for a long periods of time, even when they are charged correctly, this may indicate it is time to change the battery.

由于电池是利用化学反应的原理，所以随着时间的增加电池的性能会降低，即使是存放很长一段时间而不使用。如果使用条件如充电、放电及周围环境温度等情形不在指定的使用范围内，会使缩短电池的使用寿命，或者会产生漏液导致设备损坏。如果电池长周期不能充电，即使充电方法正确，这样需要更换电池了。

Note:

注释

Any matters that this specification does not cover should be conferred between the customer and Fuxinyuan.

其它事项任何本说明书中未提及的事项，须经双方协商确定。