

Primary lithium battery

LS 14500

3.6 V Primary lithium-thionyl chloride (Li-SOCl₂)
 High energy density
 AA-size bobbin cell



Benefits

- Enhanced capacity
- High voltage response, stable during most of the lifetime of the application
- Wide operating temperature range (-60°C/+85°C)
- Easy integration into compact system
- Superior resistance to atmospheric corrosion

Key features

- Stainless steel container and end caps (*low magnetic signature*)
- Hermetic glass-to-metal sealing
- Non-flammable electrolyte
- Low self-discharge rate (*less than 1 % after 1 year of storage at +20°C*)
- Compliant with IEC 60079-11 intrinsic safety standard
- Underwriters Laboratories (UL) Component Recognition (*File Number MH 12609*)
- Non-restricted for transport

Main applications

- Utility metering
- Automatic meter reading
- Alarms and security devices
- Tollgate systems
- Memory back-up
- Tracking systems
- Automotive electronics
- Professional electronics

Cell size references

R6 - AA

Electrical characteristics

(typical values relative to cells stored for one year or less at +30°C max.)

Nominal capacity <i>(at 2 mA +20°C 2.0 V cut-off. The capacity restored by the cell varies according to current drain, temperature and cut-off)</i>	2.6 Ah
Open circuit voltage (at +20°C)	3.67 V
Nominal voltage (at 0.2 mA +20°C)	3.6 V

Pulse capability: Typically up to 280 mA
(280 mA/0.1 second pulses, drained every 2 mn at +20°C from undischarged cells with 10 µA base current, yield voltage readings above 3.0 V. The readings may vary according to the pulse characteristics, the temperature, and the cell's previous history. Fitting the cell with a capacitor may be recommended in severe conditions. Consult Saft)

Maximum recommended continuous current <i>(Higher currents possible, consult Saft)</i>	70 mA
---	-------

Storage (recommended) <i>(for more severe conditions, consult Saft)</i>	+30°C (+86°F) max
--	-------------------

Operating temperature range <i>(Operation above ambient T may lead to reduced capacity and lower voltage readings at the beginning of pulses. Consult Saft)</i>	-60°C/+85°C (-76°F/+185°F)
--	-------------------------------

Physical characteristics

Diameter (max)	14.65 mm (0.58 in)
Height (max)	50.3 mm (1.98 in)
Typical weight	16.7 g (~0.6 oz)
Li metal content	approx. 0.7 g

Available termination suffix

CN, CNR	radial tabs
2 PF, 3 PF, 3 PF RP, 4 PF	radial pins
CNA (AX)	axial leads
FL	flying leads...etc.

勝特力材料 886-3-5753170
 勝特力电子(上海) 86-21-54151736
 勝特力电子(深圳) 86-755-83298787
[Http://www.100y.com.tw](http://www.100y.com.tw)



SAFT

LS 14500

Voltage plateau versus Current and Temperature (at mid-discharge)

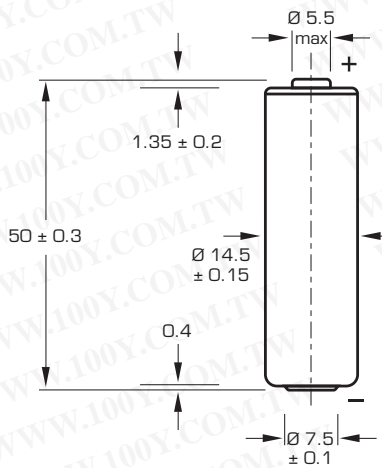
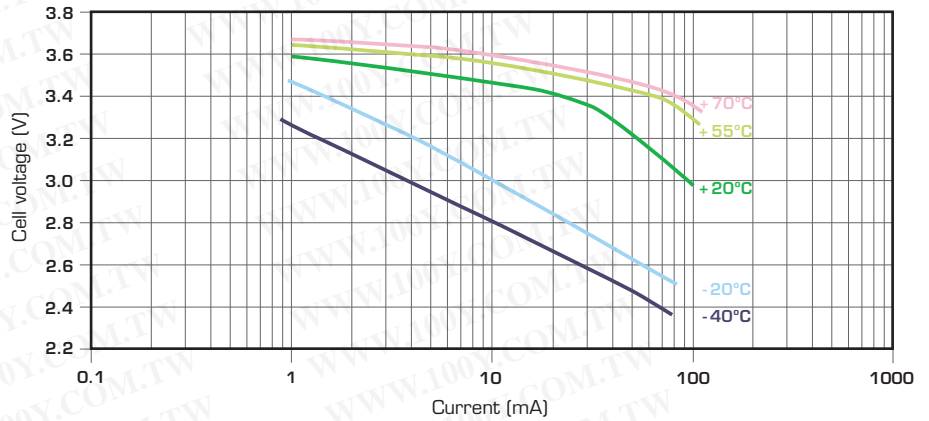

Typical discharge profiles at +20°C

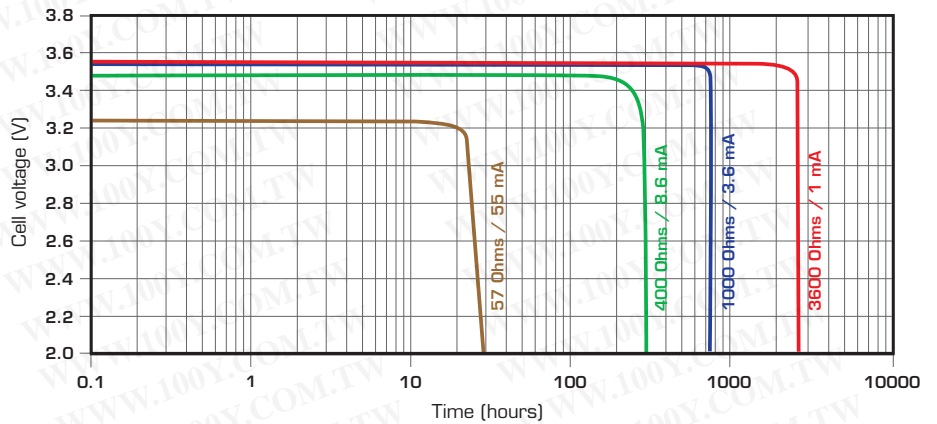

Storage

- The storage area should be clean, cool (preferably not exceeding +30°C), dry and ventilated.

Warning

- Fire, explosion and burn hazard.
- Do not recharge, short circuit, crush, disassemble, heat above 100°C (212°F), incinerate, or expose contents to water.
- Do not solder directly to the cell (use tabbed cell versions instead).

Restored Capacity versus Current and Temperature (2.0 V cut-off)

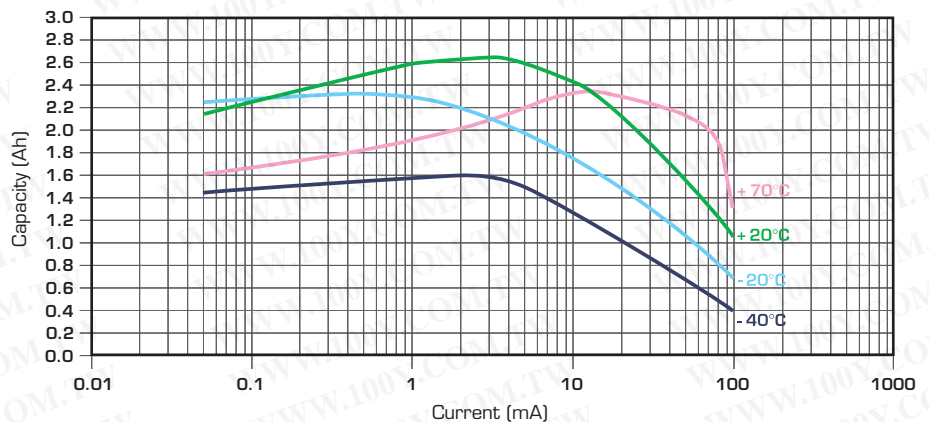

勝特力材料 886-3-5753170
 勝特力电子(上海) 86-21-54151736
 勝特力电子(深圳) 86-755-83298787
[Http://www.100y.com.tw](http://www.100y.com.tw)

