

MODEL TL-2450

勝特力材料 886-3-5753170
 勝特力电子(上海) 86-21-34970699
 勝特力电子(深圳) 86-755-83298787
[Http://www.100y.com.tw](http://www.100y.com.tw)

TECHNICAL DATA

(Typical values @+25°C for batteries stored for one year or less)

- Nominal capacity @ 0.5 mA, to 2V 0.55 Ah
- Rated voltage 3.6 V
- Maximum recommended continuous current 5 mA
- Maximum pulse current capability 10 mA
- Weight 8.8g (0.310 oz)
- Volume 2.60 cc
- Operating temperature range -55°C to +85°C
- Li metal content approx. 0.2 g
- U.L. Component Recognition MH 12193

TADIRAN LITHIUM BATTERIES

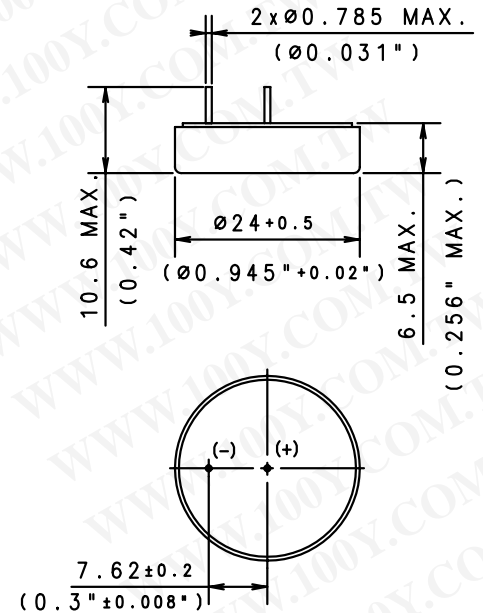

ADDITIONAL INFORMATION

SUFFIX - /P TIN PLATED NICKEL PINS
 CATALOGUE NO.: 15-2450-41000

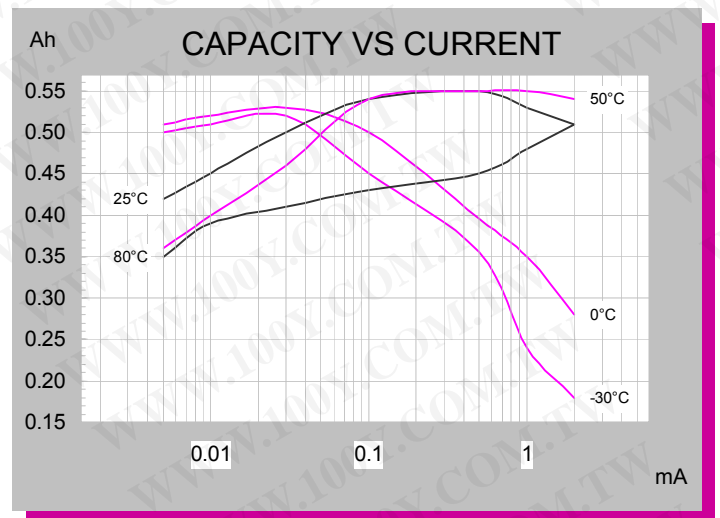
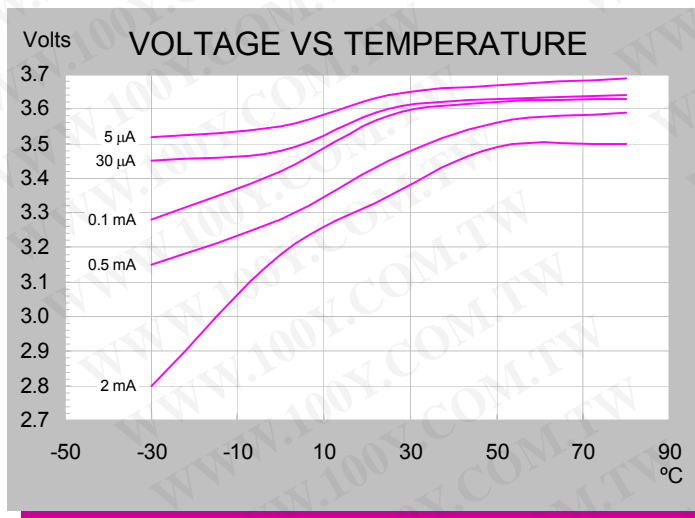
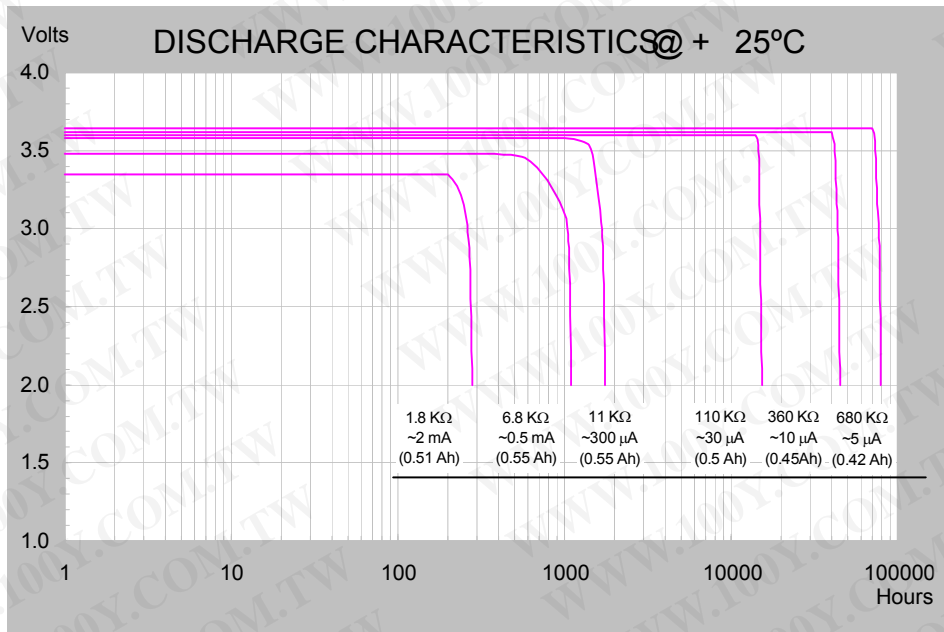

iXtra - Long Term High Performance

Note: Any presentations in this data sheet concerning performance are for information purpose only and are not construed as warranties either expressed or implied, of future performance. Rev. F 09/09 ECN 1502004

TL-2450

勝特力材料 886-3-5753170
勝特力电子(上海) 86-21-34970699
勝特力电子(深圳) 86-755-83298787
[Http://www.100y.com.tw](http://www.100y.com.tw)

TADIRAN LITHIUM BATTERIES

CELL FEATURES

- 3.6 V Primary lithium-thionyl chloride (Li-SOCl₂)
- Fast voltage recovery after long term storage and/or usage
- High energy density
- High and stable operating voltage
- Low self discharge rate
- 10 years shelf life
- Wafer construction
- Hermetic glass-to-metal-sealing
- Non-flammable electrolyte
- Non-restricted for transportation

MAIN APPLICATIONS

- Utility meters (elect., water & gas)
- Automatic meter reading
- RF systems
- Sensors & monitoring systems
- Tracking systems
- Wireless security systems
- Automotive electronics
- Industrial electronics
- Ultra Low Power (ULP)

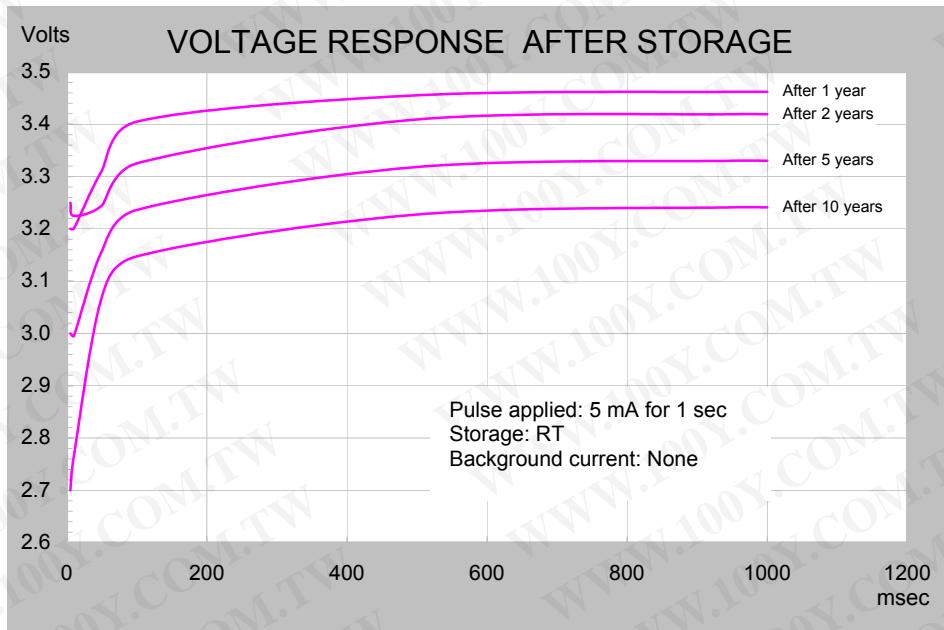

STORAGE CONDITIONS

- Cells should be stored in a clean & dry (less than 30 % RH) area

For updated information please visit our website www.tadiranbat.com

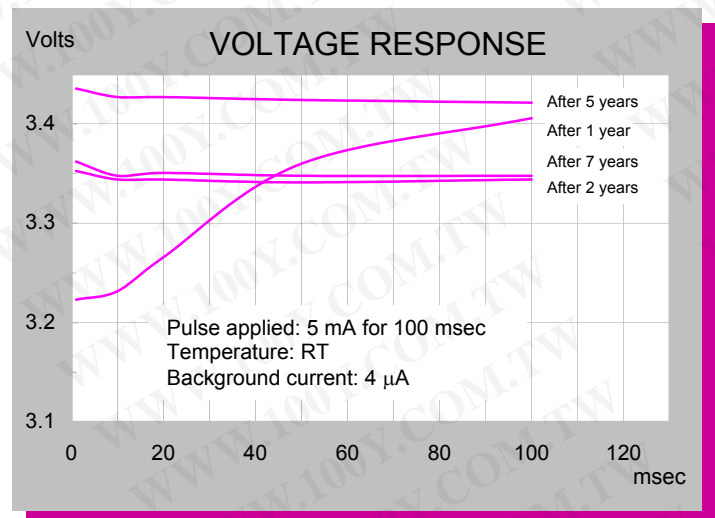
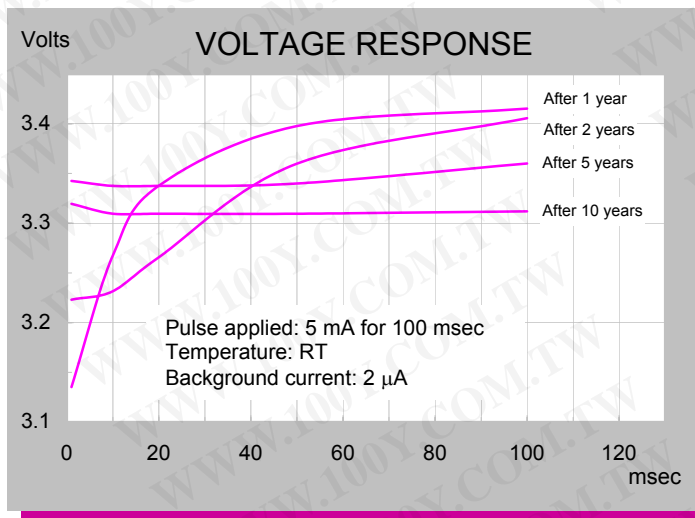

iXtra - Long Term High Performance

Note: Any presentations in this data sheet concerning performance are for information purpose only and are not construed as warranties either expressed or implied, of future performance.

Rev. F 09/09 ECN 1502004