

ADS-K8K8-1.25

2.92mm Jack To 2.92mm Jack
40GHz VSWR 1.25

50Ω

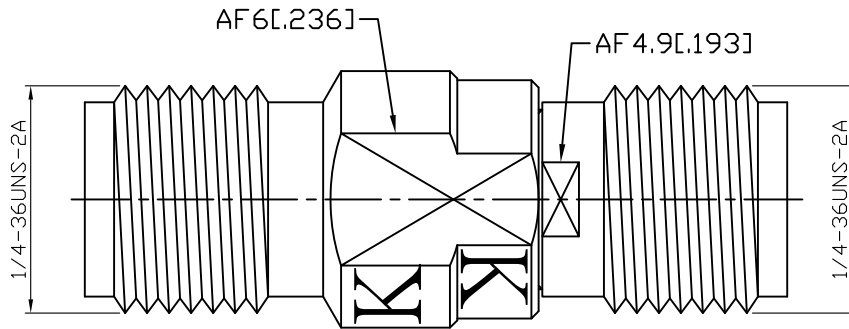

Parts	Material	Plating (Micro-inch)
Contact Pin	Beryllium Copper	Gold 4 Over Nickel-Phosphorus Alloy 80 Over Copper 20
Insulator	PPO	
Body	Stainless Steel	Passivated

This part number complies with RoHS.

Notice: JYEBAO reserves the right to make modifications deemed appropriate.

ADS-K8K8-1.25	2.92mm Jack To 2.92mm Jack 40GHz VSWR 1.25																		
<table border="0"> <tr> <td colspan="2" data-bbox="129 342 531 392">Interface</td> </tr> <tr> <td data-bbox="129 398 782 488">Standard Mechanically compatible with</td> <td data-bbox="782 398 1479 488">MIL-STD-348B 3.5 & SMA</td> </tr> </table>		Interface		Standard Mechanically compatible with	MIL-STD-348B 3.5 & SMA														
Interface																			
Standard Mechanically compatible with	MIL-STD-348B 3.5 & SMA																		
<table border="0"> <tr> <td colspan="2" data-bbox="129 602 531 651">Electrical Data</td> </tr> <tr> <td data-bbox="129 658 782 696">Impedance</td> <td data-bbox="782 658 1479 696">50Ω</td> </tr> <tr> <td data-bbox="129 703 782 741">Frequency Range</td> <td data-bbox="782 703 1479 741">DC to 40GHz</td> </tr> <tr> <td data-bbox="129 748 782 786">VSWR</td> <td data-bbox="782 748 1479 786">≤ 1.25 (DC To 40GHz)</td> </tr> <tr> <td data-bbox="129 792 782 831">Insertion Loss</td> <td data-bbox="782 792 1479 831">≤ 0.04 x √f(GHz) dB</td> </tr> <tr> <td data-bbox="129 837 782 875">Insulation Resistance</td> <td data-bbox="782 837 1479 875">≥ 5000MΩ</td> </tr> <tr> <td data-bbox="129 882 782 920">Dielectric Withstanding Voltage (at sea level)</td> <td data-bbox="782 882 1479 920">750 V rms</td> </tr> <tr> <td data-bbox="129 927 782 965">Working Voltage (at sea level)</td> <td data-bbox="782 927 1479 965">250 V rms</td> </tr> <tr> <td data-bbox="129 972 782 1010">RF Leakage</td> <td data-bbox="782 972 1479 1010">≥ 100dB to 1GHz</td> </tr> </table>		Electrical Data		Impedance	50Ω	Frequency Range	DC to 40GHz	VSWR	≤ 1.25 (DC To 40GHz)	Insertion Loss	≤ 0.04 x √f(GHz) dB	Insulation Resistance	≥ 5000MΩ	Dielectric Withstanding Voltage (at sea level)	750 V rms	Working Voltage (at sea level)	250 V rms	RF Leakage	≥ 100dB to 1GHz
Electrical Data																			
Impedance	50Ω																		
Frequency Range	DC to 40GHz																		
VSWR	≤ 1.25 (DC To 40GHz)																		
Insertion Loss	≤ 0.04 x √f(GHz) dB																		
Insulation Resistance	≥ 5000MΩ																		
Dielectric Withstanding Voltage (at sea level)	750 V rms																		
Working Voltage (at sea level)	250 V rms																		
RF Leakage	≥ 100dB to 1GHz																		
<table border="0"> <tr> <td colspan="2" data-bbox="129 1149 531 1198">Mechanical Data</td> </tr> <tr> <td data-bbox="129 1205 782 1243">Recommended Coupling Nut Torque</td> <td data-bbox="782 1205 1479 1243">11.47 in-lbs</td> </tr> <tr> <td data-bbox="129 1249 782 1288">Coupling Proof Torque</td> <td data-bbox="782 1249 1479 1288">15 in-lbs</td> </tr> <tr> <td data-bbox="129 1294 782 1332">Contact Captivation-axial</td> <td data-bbox="782 1294 1479 1332">≥ 4.9 lbs</td> </tr> <tr> <td data-bbox="129 1339 782 1377">Durability (mating)</td> <td data-bbox="782 1339 1479 1377">≥ 500</td> </tr> </table>		Mechanical Data		Recommended Coupling Nut Torque	11.47 in-lbs	Coupling Proof Torque	15 in-lbs	Contact Captivation-axial	≥ 4.9 lbs	Durability (mating)	≥ 500								
Mechanical Data																			
Recommended Coupling Nut Torque	11.47 in-lbs																		
Coupling Proof Torque	15 in-lbs																		
Contact Captivation-axial	≥ 4.9 lbs																		
Durability (mating)	≥ 500																		
<table border="0"> <tr> <td colspan="2" data-bbox="129 1503 531 1552">Environmental Data</td> </tr> <tr> <td data-bbox="129 1559 782 1597">Temperature Range</td> <td data-bbox="782 1559 1479 1597">-55°C to +105°C</td> </tr> <tr> <td data-bbox="129 1603 782 1641">Thermal Shock</td> <td data-bbox="782 1603 1479 1641">MIL-STD-202, Method 107, Condition B</td> </tr> <tr> <td data-bbox="129 1648 782 1686">Moisture Resistance</td> <td data-bbox="782 1648 1479 1686">MIL-STD-202, Method 206</td> </tr> <tr> <td data-bbox="129 1693 782 1731">Corrosion</td> <td data-bbox="782 1693 1479 1731">MIL-STD-202, Method 101, Condition B</td> </tr> <tr> <td data-bbox="129 1738 782 1776">RoHS</td> <td data-bbox="782 1738 1479 1776">Compliant</td> </tr> </table>		Environmental Data		Temperature Range	-55°C to +105°C	Thermal Shock	MIL-STD-202, Method 107, Condition B	Moisture Resistance	MIL-STD-202, Method 206	Corrosion	MIL-STD-202, Method 101, Condition B	RoHS	Compliant						
Environmental Data																			
Temperature Range	-55°C to +105°C																		
Thermal Shock	MIL-STD-202, Method 107, Condition B																		
Moisture Resistance	MIL-STD-202, Method 206																		
Corrosion	MIL-STD-202, Method 101, Condition B																		
RoHS	Compliant																		

Notice: JYEBAO reserves the right to make modifications deemed appropriate.

ADS-K8K8-1.25

