

ADS-N3AN3A-18-1.15

N Plug to N Plug
18GHz VSWR 1.15

50Ω

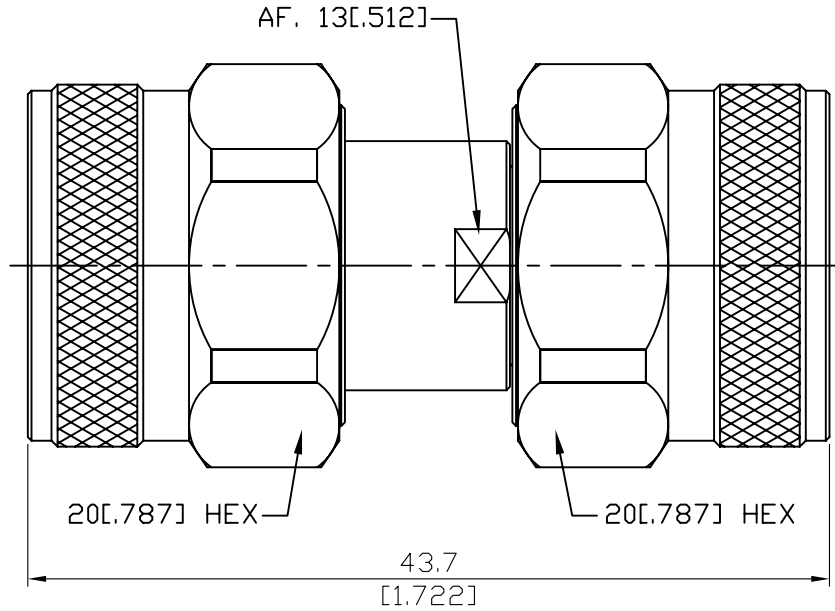

勝特力電材超市-龍山店 886-3-5773766
 勝特力電材超市-光復店 886-3-5729570
 勝特力电子(上海) 86-21-34970699
 勝特力电子(深圳) 86-755-83298787
<http://www.100y.com.tw>

Parts	Material	Plating (Micro-inch)
Retainer Ring	Beryllium Copper	Tin-Zinc-Copper-Alloy 100 Over Copper 50
Gasket	Silicone	
Contact Pin	Beryllium Copper	Gold 4 Over Nickel-Phosphorus Alloy 80 Over Copper 20
Insulator	PPO	
Body	Stainless Steel	Passivated
Coupling Nut	Stainless Steel	Passivated

ADS-N3AN3A-18-1.15	N Plug to N Plug 18GHz VSWR 1.15
<div data-bbox="129 344 531 394" style="border: 1px solid black; padding: 2px;">Interface</div> Standard	MIL-STD-348B
<div data-bbox="129 562 531 611" style="border: 1px solid black; padding: 2px;">Electrical Data</div> Impedance Frequency Range VSWR Insertion Loss Insulation Resistance Dielectric Withstanding Voltage (at sea level) Working Voltage (at sea level)	50Ω DC to 18GHz ≤ 1.15 (DC To 18GHz) $\leq 0.05 \times \sqrt{f(\text{GHz})}$ dB $\geq 5000\text{M}\Omega$ 2500 V rms 1000 V rms
<div data-bbox="129 1059 531 1108" style="border: 1px solid black; padding: 2px;">Mechanical Data</div> Recommended Coupling Nut Torque Coupling Proof Torque Coupling Nut Retention Force Contact Captivation-axial Durability (mating)	6 to 10 in-lbs 15 in-lbs ≥ 101.2 lbs ≥ 6.3 lbs ≥ 500
<div data-bbox="129 1458 531 1507" style="border: 1px solid black; padding: 2px;">Environmental Data</div> Temperature Range Thermal Shock Moisture Resistance Corrosion RoHS	-55°C to +105°C MIL-STD-202, Method 107, Condition B MIL-STD-202, Method 206 MIL-STD-202, Method 101, Condition B Compliant

ADS-N3AN3A-18-1.15

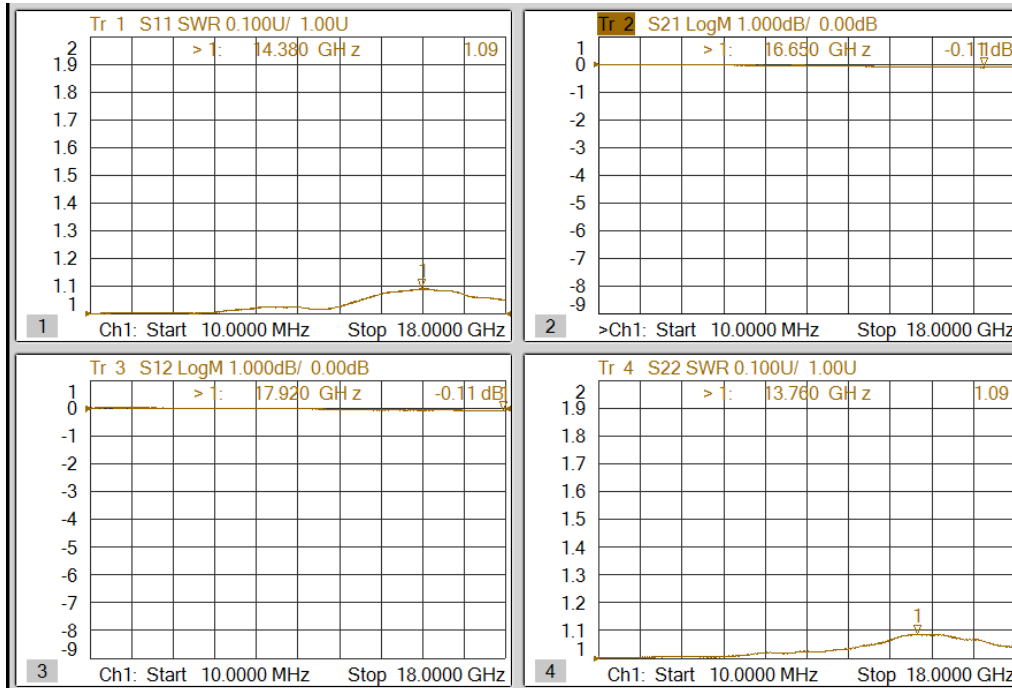

勝特力電材超市-龍山店 886-3-5773766
勝特力電材超市-光復店 886-3-5729570
勝特力電子(上海) 86-21-34970699
勝特力電子(深圳) 86-755-83298787
<http://www.100y.com.tw>