

勝特力電材超市-龍山店 886-3-5773766
 勝特力電材超市-光復店 886-3-5729570
 勝特力电子(上海) 86-21-34970699
 勝特力电子(深圳) 86-755-83298787
<http://www.100y.com.tw>

BNC3100-0058

BNC Plug Crimp For RG58, JBY195, LMR195;
1GHz VSWR 1.2; 4GHz VSWR 1.32

50Ω

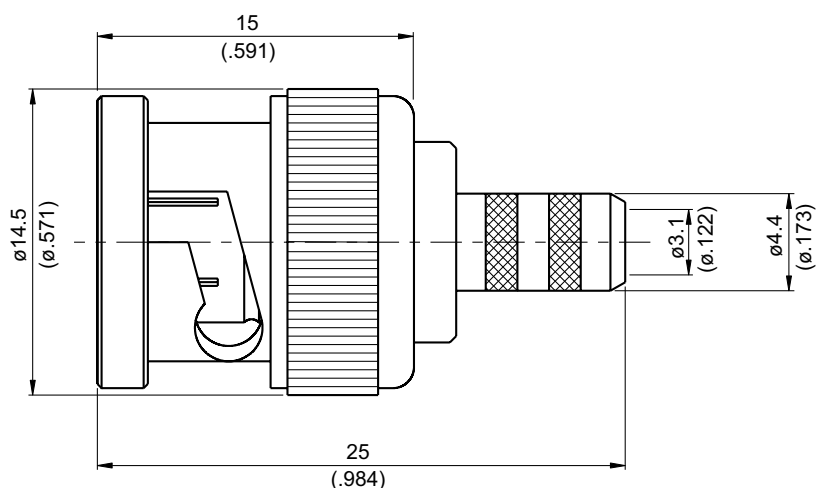

Parts	Material	Plating (Micro-inch)
Ferrule	Brass	Tin-Zinc-Copper-Alloy 100 Over Copper 50
Contact Pin	Brass	Gold 4 Over Nickel-Phosphorus Alloy 80 Over Copper 20
Gasket	Silicone	
Washer	Brass	Tin-Zinc-Copper-Alloy 100 Over Copper 50
Spring	SK5	Tin-Zinc-Copper-Alloy 100 Over Copper 50
Insulator	Teflon	
Body	Brass	Tin-Zinc-Copper-Alloy 100 Over Copper 50
Coupling Nut	Brass	Tin-Zinc-Copper-Alloy 100 Over Copper 50

Weight: 9.50 g

Suitable Cables: RG58, JBY195, LMR195

This part number complies with RoHS.

Notice: JYBAO reserves the right to make modifications deemed appropriate.

BNC	BNC3100-0058																		
<div data-bbox="169 344 571 394" style="border: 1px solid black; padding: 2px;">Interface</div> MIL-STD-348B																			
<div data-bbox="169 512 571 562" style="border: 1px solid black; padding: 2px;">Electrical Data</div> <table border="0" style="width: 100%;"> <tr> <td style="width: 50%;">Impedance</td> <td style="width: 50%;">50Ω</td> </tr> <tr> <td>Frequency range</td> <td>DC to 4GHz</td> </tr> <tr> <td>VSWR</td> <td>≤ 1.2 (1GHz) ; ≤ 1.32 (4GHz)</td> </tr> <tr> <td>Insertion loss</td> <td>$\leq 0.1 \times \sqrt{f(\text{GHz})}$dB</td> </tr> <tr> <td>Insulation resistance</td> <td>$\geq 5000\text{M}\Omega$</td> </tr> <tr> <td>Contact resistance inner conductor</td> <td>$\leq 1.5\text{m}\Omega$</td> </tr> <tr> <td>Contact resistance outer conductor</td> <td>$\leq 1\text{m}\Omega$</td> </tr> <tr> <td>Dielectric withstanding voltage (at sea level)</td> <td>1500 V rms</td> </tr> <tr> <td>Working voltage (at sea level)</td> <td>500 V rms</td> </tr> </table>		Impedance	50Ω	Frequency range	DC to 4GHz	VSWR	≤ 1.2 (1GHz) ; ≤ 1.32 (4GHz)	Insertion loss	$\leq 0.1 \times \sqrt{f(\text{GHz})}$ dB	Insulation resistance	$\geq 5000\text{M}\Omega$	Contact resistance inner conductor	$\leq 1.5\text{m}\Omega$	Contact resistance outer conductor	$\leq 1\text{m}\Omega$	Dielectric withstanding voltage (at sea level)	1500 V rms	Working voltage (at sea level)	500 V rms
Impedance	50Ω																		
Frequency range	DC to 4GHz																		
VSWR	≤ 1.2 (1GHz) ; ≤ 1.32 (4GHz)																		
Insertion loss	$\leq 0.1 \times \sqrt{f(\text{GHz})}$ dB																		
Insulation resistance	$\geq 5000\text{M}\Omega$																		
Contact resistance inner conductor	$\leq 1.5\text{m}\Omega$																		
Contact resistance outer conductor	$\leq 1\text{m}\Omega$																		
Dielectric withstanding voltage (at sea level)	1500 V rms																		
Working voltage (at sea level)	500 V rms																		
<div data-bbox="169 1055 571 1104" style="border: 1px solid black; padding: 2px;">Mechanical Data</div> <table border="0" style="width: 100%;"> <tr> <td style="width: 50%;">Recommended coupling nut torque</td> <td style="width: 50%;">0.6 to 2.5 inch lbs</td> </tr> <tr> <td>Coupling nut retention force</td> <td>≥ 101.2 lbs</td> </tr> <tr> <td>Contact captivation-axial</td> <td>≥ 6.1 lbs</td> </tr> <tr> <td>Durability (mating)</td> <td>≥ 500</td> </tr> </table>		Recommended coupling nut torque	0.6 to 2.5 inch lbs	Coupling nut retention force	≥ 101.2 lbs	Contact captivation-axial	≥ 6.1 lbs	Durability (mating)	≥ 500										
Recommended coupling nut torque	0.6 to 2.5 inch lbs																		
Coupling nut retention force	≥ 101.2 lbs																		
Contact captivation-axial	≥ 6.1 lbs																		
Durability (mating)	≥ 500																		
<div data-bbox="169 1359 571 1408" style="border: 1px solid black; padding: 2px;">Environmental Data</div> <table border="0" style="width: 100%;"> <tr> <td style="width: 50%;">Temperature range</td> <td style="width: 50%;">-65°C to +165°C</td> </tr> <tr> <td>Thermal shock</td> <td>MIL-STD-202, Method 107, Condition B</td> </tr> <tr> <td>Moisture resistance</td> <td>MIL-STD-202, Method 106</td> </tr> <tr> <td>Corrosion</td> <td>MIL-STD-202, Method 101, Condition B</td> </tr> <tr> <td>RoHS</td> <td>Compliant</td> </tr> </table>		Temperature range	-65°C to +165°C	Thermal shock	MIL-STD-202, Method 107, Condition B	Moisture resistance	MIL-STD-202, Method 106	Corrosion	MIL-STD-202, Method 101, Condition B	RoHS	Compliant								
Temperature range	-65°C to +165°C																		
Thermal shock	MIL-STD-202, Method 107, Condition B																		
Moisture resistance	MIL-STD-202, Method 106																		
Corrosion	MIL-STD-202, Method 101, Condition B																		
RoHS	Compliant																		
<div data-bbox="169 1711 571 1760" style="border: 1px solid black; padding: 2px;">Tooling</div> <table border="0" style="width: 100%;"> <tr> <td style="width: 50%;">Crimping tool</td> <td style="width: 50%;">CRT-1 or CRT-2</td> </tr> <tr> <td>Crimp insert</td> <td>INSERT-B</td> </tr> </table>		Crimping tool	CRT-1 or CRT-2	Crimp insert	INSERT-B														
Crimping tool	CRT-1 or CRT-2																		
Crimp insert	INSERT-B																		

Notice: JYEBAO reserves the right to make modifications deemed appropriate.

BNC3100-0058	DATE	2021/02/25	REV	A
--------------	------	------------	-----	---





A	B	C
		
BODY	CONTACT PIN	FERRULE

DIAGRAM	ASSEMBLY INSTRUCTION
---------	----------------------

	<p>Step 1: STRIP AS SHOWN.</p>
--	--------------------------------

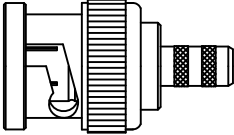
	<p>Step 2: SLIDE FERRULE " C " OVER CABLE. Step 3: PUT PIN " B " ON CENTER CONDUCTOR AND SOLDER OR CRIMP IN " Y ". (USE SQUARE 1.6mm/0.063inch SECTION OF INSERT-B IF CRIMPED)</p>
---	--

	<p>Step 4: LOOSEN BRAIDING AND SLIDE CONNECTOR " A " IN PLACE.</p>
---	--

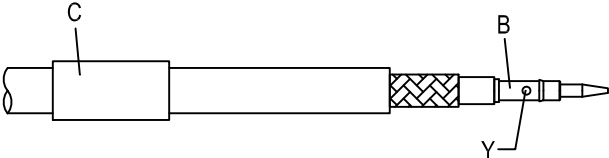
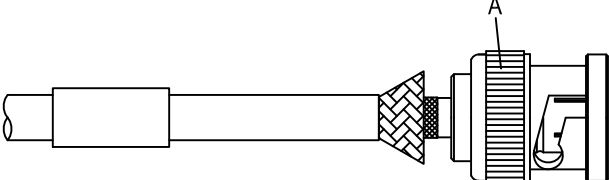
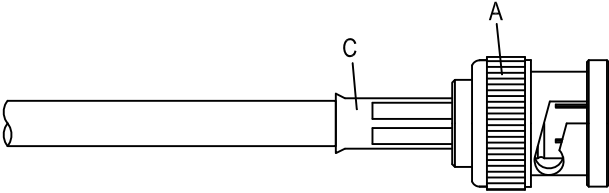
	<p>Step 5: SLIDE FERRULE " C " TOWARDS THE CONNECTOR " A " AND CRIMP. (USE 5.5mm/0.217inch HEX SECTION OF INSERT-B)</p>
---	--

<p>This part number complies with RoHS. Notice: JYEBAO reserves the right to make modifications deemed appropriate.</p>		
APPROVED	CHECKED	DRAWING
		<i>Albert</i>

BNC3100-0058

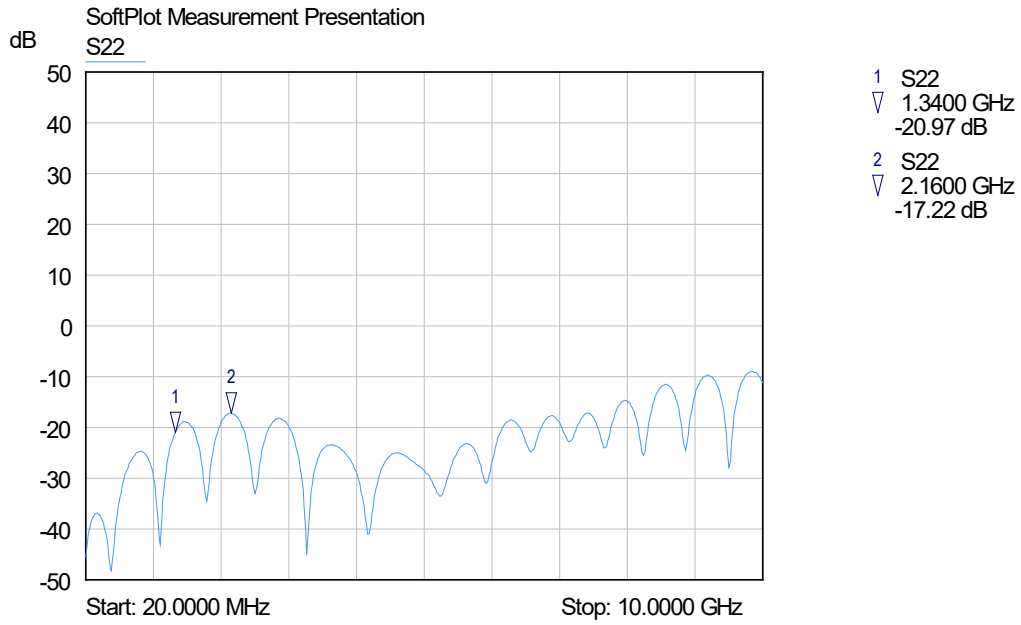

勝特力電材超市-龍山店 886-3-5773766
勝特力電材超市-光復店 886-3-5729570
勝特力電子(上海) 86-21-34970699
勝特力電子(深圳) 86-755-83298787
<http://www.100y.com.tw>