

MHV8200B-0058

MHV Jack Clamp

50Ω

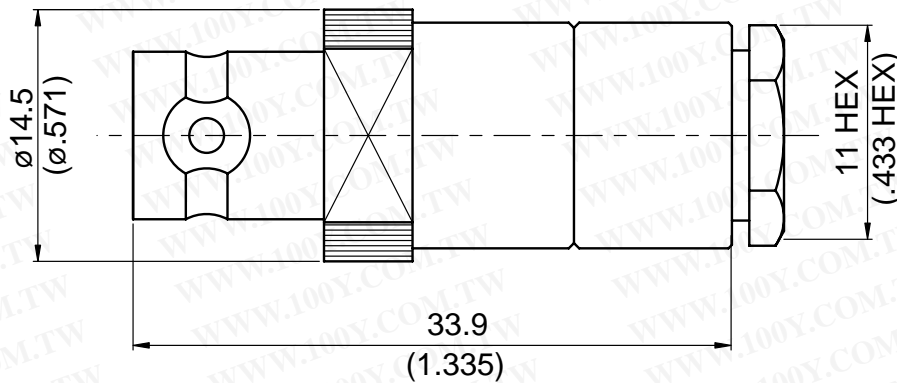

Parts	Material	Plating(Micro-inch)
Hex Nut	Brass	Tin-Zinc-Copper-Alloy 100 Over Copper 50
Washer	Brass	Tin-Zinc-Copper-Alloy 100 Over Copper 50
Gasket	Silicon	
Braid Clamp	Brass	Tin-Zinc-Copper-Alloy 100 Over Copper 50
Insulator	Teflon	
Contact Pin	Phosphor Bronze	Gold 5 Over Nickel 50 Over Copper 50
Insulator	Teflon	
Body	Brass	Tin-Zinc-Copper-Alloy 100 Over Copper 50

Weight: 20.13 g

Suitable Cables: RG58, JBY195, RG55, RG142, RG400, RG142-E

This part number complies with RoHS.

Notice: JYEBAO reserves the right to make modifications deemed appropriate.

CABLE ASSEMBLY INSTRUCTION

MHV8200B-0058

JYE BAO CO., LTD.

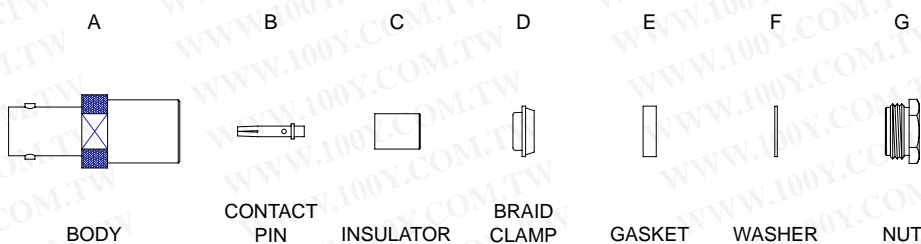

DIAGRAM	ASSEMBLY INSTRUCTION
	Step 1: STRIP AS SHOWN .
	Step 2: SLIDE BRAID CLAMP " D " ,GASKET " E " , WASHER " F " AND NUT " G" OVER CABLE .
	Step 3: WRAP THE BRAIDING OVER " D " .
	Step 4: STRIP AS SHOWN .
	Step 5: SLIDE PREPARED CABLE INTO INSULATOR " C " . Step 6: PUT CONTACT PIN " B " ON CENTER CONDUCTOR AND SOLDER IN " Y " .
	Step 7: FINALLY SCREW " G " ON THE CONNECTOR BODY " A " .

This part number complies with RoHS.

Notice: JYEBAO reserves the right to make modifications deemed appropriate.