

勝特力電材超市-龍山店 886-3-5773766  
 勝特力電材超市-光復店 886-3-5729570  
 勝特力电子(上海) 86-21-34970699  
 勝特力电子(深圳) 86-755-83298787  
<http://www.100y.com.tw>

SMA3100-0058

SMA Plug Crimp For RG58, JBY195, LMR195  
6GHz VSWR 1.2\*

50Ω

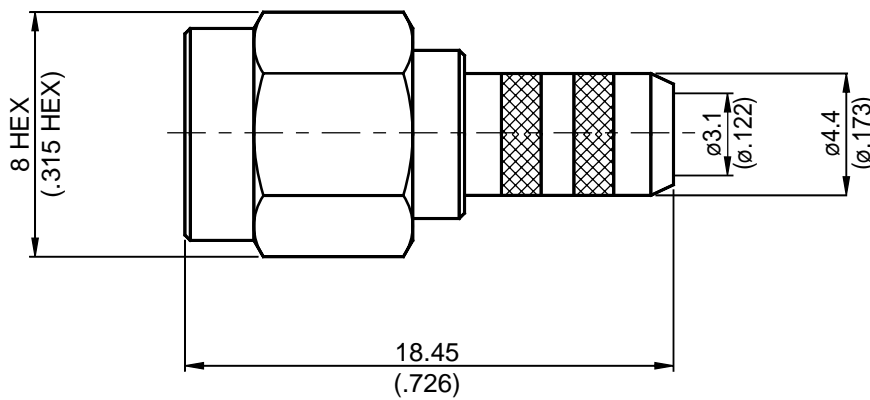

Parts	Material	Plating (Micro-inch)
Ferrule	Brass	Gold 4 Over Nickel-Phosphorus Alloy 80 Over Copper 20
Contact Pin	Brass	Gold 4 Over Nickel-Phosphorus Alloy 80 Over Copper 20
Renber Ring	Beryllium Copper	Tin-Zinc-Copper-Alloy 100 Over Copper 50
Gasket	Silicon	
Insulator	Teflon	
Body	Brass	Gold 4 Over Nickel-Phosphorus Alloy 80 Over Copper 20
Coupling Nut	Brass	Gold 4 Over Nickel-Phosphorus Alloy 80 Over Copper 20

Weight: 4.12 g

Suitable Cables: RG58, JBY195, LMR195

This part number complies with RoHS.

Notice: JYBAO reserves the right to make modifications deemed appropriate.

SMA	SMA3100-0058
<div data-bbox="169 383 568 432" style="border: 1px solid black; padding: 2px;">Interface</div> <p data-bbox="169 443 384 472">MIL-STD-348B</p> <p data-bbox="169 488 1007 517">Mechanically compatible with 2.92 &amp; 3.5</p>	
<div data-bbox="169 551 568 600" style="border: 1px solid black; padding: 2px;">Electrical Data</div> <p data-bbox="169 607 916 636">Impedance 50Ω</p> <p data-bbox="169 651 1027 680">Frequency range DC to 6GHz</p> <p data-bbox="169 696 1134 725">VSWR <math>\leq 1.2</math> (DC to 6GHz)</p> <p data-bbox="169 741 1150 770">Insertion loss <math>\leq 0.04 \times \sqrt{f(\text{GHz})}</math> dB</p> <p data-bbox="169 786 1007 815">Insulation resistance <math>\geq 5000\text{M}\Omega</math></p> <p data-bbox="169 831 954 860">Contact resistance inner conductor <math>\leq 3\text{m}\Omega</math></p> <p data-bbox="169 875 954 904">Contact resistance outer conductor <math>\leq 2\text{m}\Omega</math></p> <p data-bbox="169 920 1018 949">Dielectric withstanding voltage (at sea level) 1000 V rms</p> <p data-bbox="169 965 1018 994">Working voltage (at sea level) 335 V rms</p>	
<div data-bbox="169 1093 568 1142" style="border: 1px solid black; padding: 2px;">Mechanical Data</div> <p data-bbox="169 1149 991 1178">Recommended coupling nut torque 4 inch lbs</p> <p data-bbox="169 1193 1018 1223">Coupling proof torque 5.3 inch lbs</p> <p data-bbox="169 1238 999 1267">Coupling nut retention force <math>\geq 60.7</math> lbs</p> <p data-bbox="169 1283 979 1312">Contact Captivation-axial <math>\geq 6.1</math> lbs</p> <p data-bbox="169 1328 938 1357">Durability (mating) <math>\geq 100</math></p>	
<div data-bbox="169 1402 568 1451" style="border: 1px solid black; padding: 2px;">Environmental Data</div> <p data-bbox="169 1458 1091 1487">Temperature range -65°C to +165°C</p> <p data-bbox="169 1503 1422 1532">Thermal shock MIL-STD-202, Method 107, Condition B</p> <p data-bbox="169 1547 1235 1576">Moisture resistance MIL-STD-202, Method 106</p> <p data-bbox="169 1592 1422 1621">Corrosion MIL-STD-202, Method 101, Condition B</p> <p data-bbox="169 1637 1002 1666">RoHS Compliant</p>	
<div data-bbox="169 1749 568 1798" style="border: 1px solid black; padding: 2px;">Tooling</div> <p data-bbox="169 1805 804 1834">Crimping tool CRT-1 or CRT-2</p> <p data-bbox="169 1850 724 1879">Crimp insert INSERT-B</p> <p data-bbox="169 1895 671 1924">Soldering gauge ST-0.3</p>	

Notice: JYEBAO reserves the right to make modifications deemed appropriate.

# CABLE ASSEMBLY RECOMMENDATION

SMA3100-0058	DATE	2017/07/04	REV	—
--------------	------	------------	-----	---





<p>A</p>  <p>BODY</p>	<p>B</p>  <p>CONTACT PIN</p>	<p>C</p>  <p>FERRULE</p>
--	---	---

DIAGRAM	ASSEMBLY INSTRUCTION
---------	----------------------

	<p>Step 1: STRIP AS SHOWN.</p>
--	--------------------------------

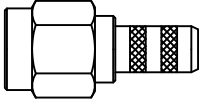
	<p>Step 2: SLIDE FERRULE " C " OVER CABLE.          Step 3: PUT 0.3 MM GAGE IN PLACE, INSERT CABLE'S CENTER CONDUCTOR INTO CENTER PIN " B " AND SOLDER IN " Y ".</p>
---	--

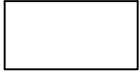
	<p>Step 4: LOOSEN BRAIDING AND SLIDE CONNECTOR " A " IN PLACE.</p>
---	--

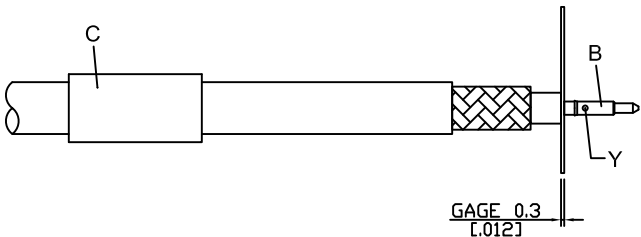
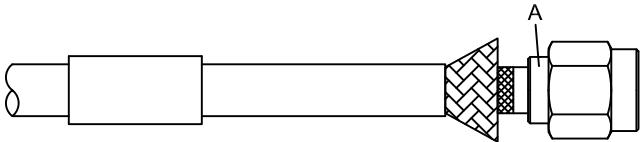
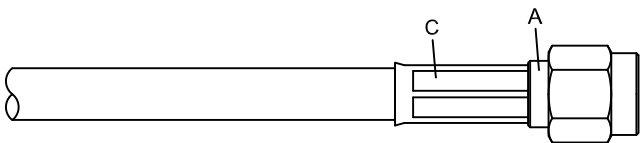
	<p>Step 5: SLIDE FERRULE " C " TOWARDS THE CONNECTOR " A " AND CRIMP.          (USE 5.5mm/0.217inch HEX SECTION OF INSERT-B)</p>
---	--

This part number complies with RoHS.

Notice: JYEBAO reserves the right to make modifications deemed appropriate.

APPROVED	CHECKED	DRAWING
----------	---------	---------

*Albert*

# SMA3100-0058

S11

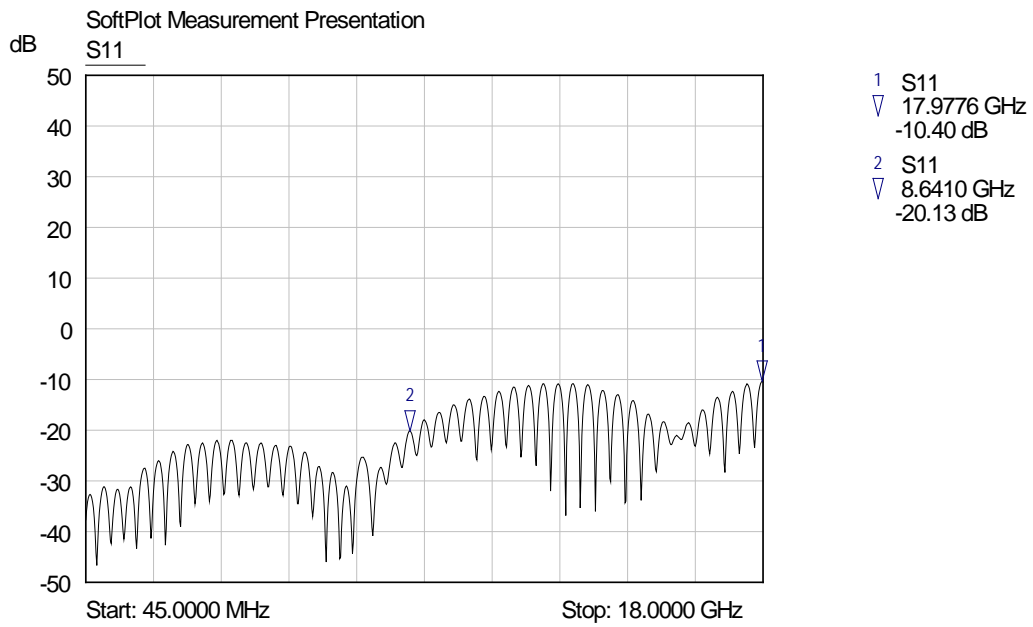

勝特力電材超市-龍山店 886-3-5773766  
勝特力電材超市-光復店 886-3-5729570  
勝特力電子(上海) 86-21-34970699  
勝特力電子(深圳) 86-755-83298787  
<http://www.100y.com.tw>