

勝特力電材超市-龍山店 886-3-5773766
 勝特力電材超市-光復店 886-3-5729570
 勝特力電子(上海) 86-21-34970699
 勝特力電子(深圳) 86-755-83298787
<http://www.100y.com.tw>

SMA3100-L400

SMA Plug Crimp

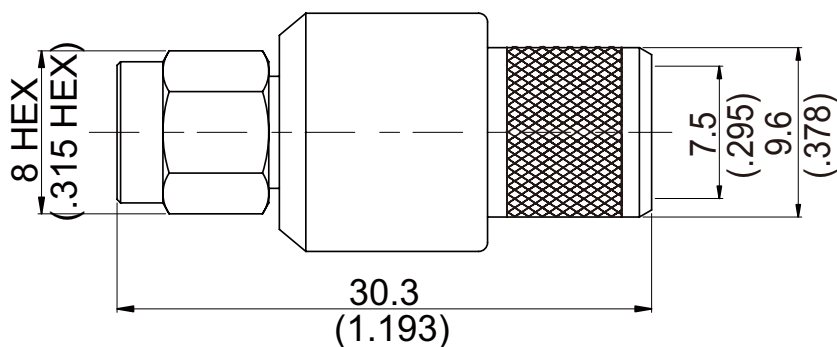

50Ω



Parts	Material	Plating(Micro-inch)
Ferrule	Brass	Tin-Zinc-Copper-Alloy 100 Over Copper 50
Contact Pin	Brass	Gold 20 Over Nickel 50 Over Copper 50
Renbrock Ring	Beryllium Copper	Tin-Zinc-Copper-Alloy 100 Over Copper 50
Gasket	Silicon	
Barrel	Brass	Tin-Zinc-Copper-Alloy 100 Over Copper 50
Insulator	Teflon	
Body	Brass	Tin-Zinc-Copper-Alloy 100 Over Copper 50
Coupling Nut	Brass	Tin-Zinc-Copper-Alloy 100 Over Copper 50

Weight: 34.22 g

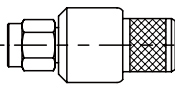
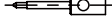
Suitable Cables: LMR400, JBY400

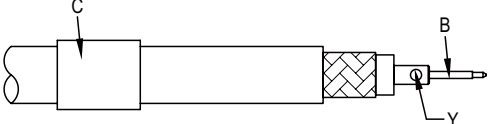
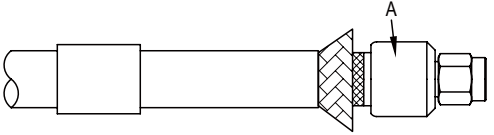
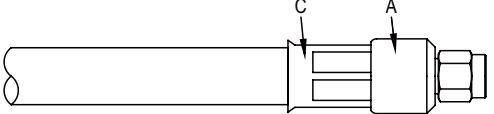
SMA3100-L400		DATE	2014/04/29	REV	—
A	B	C			
					
BODY	CONTACT PIN	FERRULE			
DIAGRAM		ASSEMBLY INSTRUCTION			
		Step 1: STRIP AS SHOWN.			
		Step 2: SLIDE FERRULE " C " OVER CABLE. Step 3: PUT PIN " B " ON CENTER CONDUCTOR AND SOLDER IN " Y ".			
		Step 4: LOOSEN BRAIDING AND SLIDE CONNECTOR " A " IN PLACE.			
		Step 5: SLIDE FERRULE " C " TOWARDS THE CONNECTOR " A " AND CRIMP. (USE 10.7mm/0.421inch HEX SECTION OF INSERT-C)			