

勝特力電材超市-龍山店 886-3-5773766
 勝特力電材超市-光復店 886-3-5729570
 勝特力电子(上海) 86-21-34970699
 勝特力电子(深圳) 86-755-83298787
<http://www.100y.com.tw>

SMA9100L-0316

SMA Reverse Polarity Jack Crimp Bulkhead 50Ω
For RG174, RG188, RG316; 6GHz VSWR 1.25

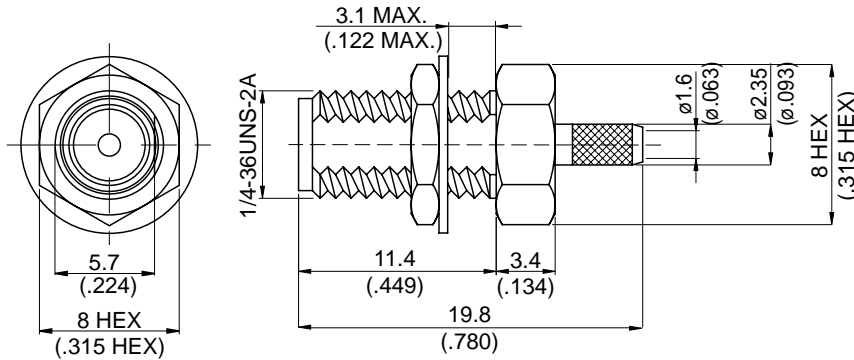

MOUNTING HOLE :

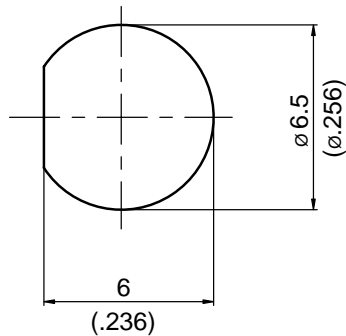

Parts	Material	Plating (Micro-inch)
Ferrule	Brass	Gold 4 Over Nickel-Phosphorus Alloy 80 Over Copper 20
Hex Nut	Brass	Gold 4 Over Nickel-Phosphorus Alloy 80 Over Copper 20
Lock Washer	Brass	Gold 4 Over Nickel-Phosphorus Alloy 80 Over Copper 20
Contact Pin	Brass	Gold 4 Over Nickel-Phosphorus Alloy 80 Over Copper 20
Barrel	Brass	Gold 4 Over Nickel-Phosphorus Alloy 80 Over Copper 20
Insulator	Teflon	
Body	Brass	Gold 4 Over Nickel-Phosphorus Alloy 80 Over Copper 20

Weight: 3.65 g

Suitable Cables: RG174, RG188, RG316, RG316-FEP



This part number complies with RoHS.

Notice: JYBAO reserves the right to make modifications deemed appropriate.

SMA	SMA9100L-0316																		
<div data-bbox="169 387 568 432" style="border: 1px solid black; padding: 2px;">Interface</div> <p data-bbox="169 443 1086 477">Per JYEBAO SMA Reverse Polarity derived from MIL-STD-348B</p>																			
<div data-bbox="169 551 568 595" style="border: 1px solid black; padding: 2px;">Electrical Data</div> <table data-bbox="169 600 1150 1025"> <tr> <td>Impedance</td> <td>50Ω</td> </tr> <tr> <td>Frequency range</td> <td>DC to 6GHz</td> </tr> <tr> <td>VSWR</td> <td>≤ 1.25 (DC to 6GHz)</td> </tr> <tr> <td>Insertion loss</td> <td>≤ 0.04 x √f(GHz) dB</td> </tr> <tr> <td>Insulation resistance</td> <td>≥ 5000MΩ</td> </tr> <tr> <td>Contact resistance inner conductor</td> <td>≤ 3mΩ</td> </tr> <tr> <td>Contact resistance outer conductor</td> <td>≤ 2mΩ</td> </tr> <tr> <td>Dielectric withstanding voltage (at sea level)</td> <td>750 V rms</td> </tr> <tr> <td>Working voltage (at sea level)</td> <td>250 V rms</td> </tr> </table>		Impedance	50Ω	Frequency range	DC to 6GHz	VSWR	≤ 1.25 (DC to 6GHz)	Insertion loss	≤ 0.04 x √f(GHz) dB	Insulation resistance	≥ 5000MΩ	Contact resistance inner conductor	≤ 3mΩ	Contact resistance outer conductor	≤ 2mΩ	Dielectric withstanding voltage (at sea level)	750 V rms	Working voltage (at sea level)	250 V rms
Impedance	50Ω																		
Frequency range	DC to 6GHz																		
VSWR	≤ 1.25 (DC to 6GHz)																		
Insertion loss	≤ 0.04 x √f(GHz) dB																		
Insulation resistance	≥ 5000MΩ																		
Contact resistance inner conductor	≤ 3mΩ																		
Contact resistance outer conductor	≤ 2mΩ																		
Dielectric withstanding voltage (at sea level)	750 V rms																		
Working voltage (at sea level)	250 V rms																		
<div data-bbox="169 1093 568 1137" style="border: 1px solid black; padding: 2px;">Mechanical Data</div> <table data-bbox="169 1142 1018 1328"> <tr> <td>Recommended coupling nut torque</td> <td>4 inch lbs</td> </tr> <tr> <td>Coupling proof torque</td> <td>5.3 inch lbs</td> </tr> <tr> <td>Contact Captivation-axial</td> <td>≥ 6.1 lbs</td> </tr> <tr> <td>Durability (mating)</td> <td>≥ 100</td> </tr> </table>		Recommended coupling nut torque	4 inch lbs	Coupling proof torque	5.3 inch lbs	Contact Captivation-axial	≥ 6.1 lbs	Durability (mating)	≥ 100										
Recommended coupling nut torque	4 inch lbs																		
Coupling proof torque	5.3 inch lbs																		
Contact Captivation-axial	≥ 6.1 lbs																		
Durability (mating)	≥ 100																		
<div data-bbox="169 1402 568 1447" style="border: 1px solid black; padding: 2px;">Environmental Data</div> <table data-bbox="169 1451 1422 1682"> <tr> <td>Temperature range</td> <td>-65°C to +165°C</td> </tr> <tr> <td>Thermal shock</td> <td>MIL-STD-202, Method 107, Condition B</td> </tr> <tr> <td>Moisture resistance</td> <td>MIL-STD-202, Method 106</td> </tr> <tr> <td>Corrosion</td> <td>MIL-STD-202, Method 101, Condition B</td> </tr> <tr> <td>RoHS</td> <td>Compliant</td> </tr> </table>		Temperature range	-65°C to +165°C	Thermal shock	MIL-STD-202, Method 107, Condition B	Moisture resistance	MIL-STD-202, Method 106	Corrosion	MIL-STD-202, Method 101, Condition B	RoHS	Compliant								
Temperature range	-65°C to +165°C																		
Thermal shock	MIL-STD-202, Method 107, Condition B																		
Moisture resistance	MIL-STD-202, Method 106																		
Corrosion	MIL-STD-202, Method 101, Condition B																		
RoHS	Compliant																		
<div data-bbox="169 1749 568 1794" style="border: 1px solid black; padding: 2px;">Tooling</div> <table data-bbox="169 1798 804 1888"> <tr> <td>Crimping tool</td> <td>CRT-1 or CRT-2</td> </tr> <tr> <td>Crimp insert</td> <td>INSERT-A</td> </tr> </table>		Crimping tool	CRT-1 or CRT-2	Crimp insert	INSERT-A														
Crimping tool	CRT-1 or CRT-2																		
Crimp insert	INSERT-A																		

Notice: JYEBAO reserves the right to make modifications deemed appropriate.

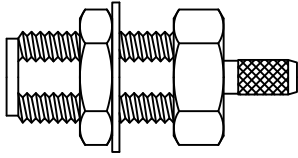
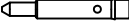
CABLE ASSEMBLY INSTRUCTION

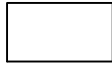
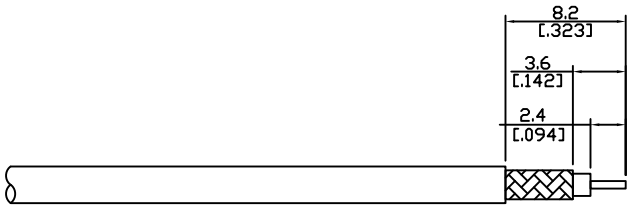
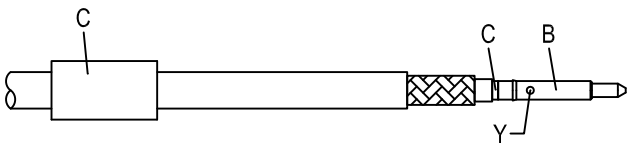
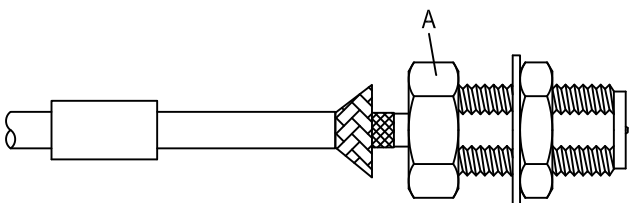
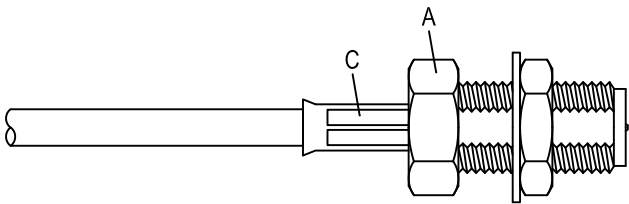
SMA9100L-0316	DATE	2020/05/15	REV	—
A	B	C	D	
				
BODY	CONTACT PIN	INSULATOR	FERRULE	
DIAGRAM	ASSEMBLY INSTRUCTION			
	Step 1: STRIP AS SHOWN.			
	Step 2: SLIDE FERRULE " C " OVER CABLE. Step 3: PUT INSULATOR " C " AND PIN " B " ON CENTER CONDUCTOR AND SOLDER IN " Y ".			
	Step 4: LOOSEN BRAIDING AND SLIDE CONNECTOR " A " IN PLACE.			
	Step 5: SLIDE FERRULE " C " TOWARDS THE CONNECTOR " A " AND CRIMP. (USE 3.3mm/0.130inch HEX SECTION OF INSERT-A)			
<p>This part number complies with RoHS. Notice: JYEBAO reserves the right to make modifications deemed appropriate.</p>				
APPROVED	CHECKED	DRAWING	<i>Albert</i>	

SMA9100L-0316

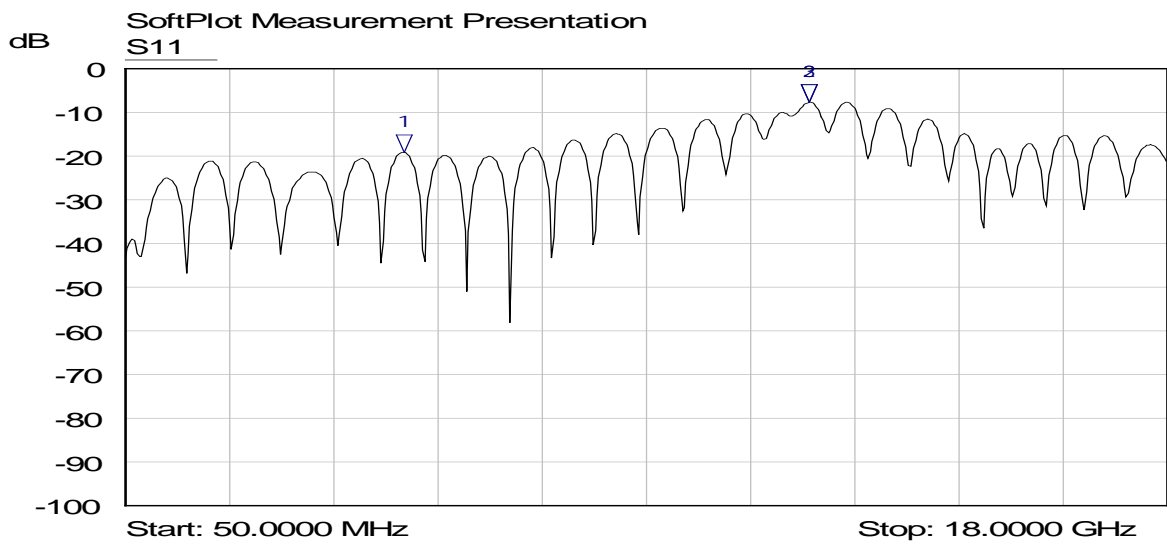

Mkr	Trace	X-Axis	Value	Notes
1 ▽	S11	4.8464 GHz	-19.11 dB	
2 ▽	S11	11.8313 GHz	-7.66 dB	
3 ▽	S11	11.8313 GHz	-7.66 dB	

勝特力電材超市-龍山店 886-3-5773766
勝特力電材超市-光復店 886-3-5729570
勝特力电子(上海) 86-21-34970699
勝特力电子(深圳) 86-755-83298787
<http://www.100y.com.tw>