

# RG 316



内部导体  
Inner Conductor

绝缘体  
Dielectric

外部导体  
Outer Conductor

护套  
Jacket

## 型号 Model

FEP RG 316

## 描述 Description

(316) 高频同轴电缆 FEP(茶色)护套  
(316) High Frequency coaxial cable with FEP (Brown) jacket

## 结构参数 Structure parameter

内部导体 Inner Conductor	镀银铜, 镀银铜包钢 Silver-Plated Copper, Silver-Plated Copper Clad Steel	7x0.175mm
绝缘层 Insulation Layer	聚四氟乙烯(PTFE) Polytetrafluoroethylene(PTFE)	1.53mm
外部导体 Outer Conductor	镀银铜线编织 Silver-Plated Copper Wire Braiding	1.95mm
护套 Jacket	聚全氟乙丙烯 (FEP), 茶色 Fluorinated Ethylene Propylene (FEP), Brown	2.50mm

## 电气特性 Electrical Data

阻抗 Impedance, nominal	50ohms
电容 Capacitance, nominal	106pF/m
延时 Signal delay, nominal	4.7ns/m
耐电压 Voltage withstand(AC)	2000V rms/min
绝缘电阻 Insulation resistance, nominal	1500 M $\Omega$ · km
传输速率 Velocity of propagation, nominal	70%

## 机械特性 Mechanical Data

恒定温度 Temperature rating	150°C
最小弯曲半径 Minimum bending radius	15mm
最大拉伸强度 Maximum tensile strength	3.4kg
重量 Weight of cable	17g/m

## 衰减量和功率 Attenuation and Power

频率数 Frequency(MHz)	衰减量 Attenuation(dB/m)	功率 Power(Watts CW)
100	0.29	420
400	0.58	210
900	0.88	140
1000	0.93	135
1800	1.27	100
2400	1.46	78
3000	1.65	72
5000	2.14	61
6000	2.34	52

# 产品规格书

## PRODUCT SPECIFICATION

This document contains proprietary information and such information may not be disclosed to others for any purposes,  
本文件包含专有信息，不得出于任何目的向他人披露此类信息。  
not used for sales/marketing/procurement purposes without written permission.  
未经书面许可，不得用于销售/营销/采购目的。

- 1..Electrical/电气
  - 1.1 Impedance /阻抗 50Ω
  - 1.2 Frequency /频率 DC-6GHz
  - 1.3 VSWR/驻波  $\leq 1.2$
  - 1.4 Dielectric withstanding voltage /介质耐压 1000V(rms)
  - 1.5 Center contact resistance /中心接触电阻  $\leq 3m\Omega$
  - 1.6 Outer contact resistance /外部接触电阻  $\leq 2m\Omega$
  - 1.7 Insulation resistance /绝缘电阻  $\geq 5000M\Omega$

- 2 Environment & Mechanical /环境与机械
  - 2.1 Temperature range /温度范围  $-45^{\circ}\sim +125^{\circ}$
  - 2.2 Rohs Compliant /符合RoHS
  - 2.3 Durability /耐久性 500cycles

- 3 Material and Plating /材料和电镀
  - 3.1 Inner Contact /内导体: Brass, Gold plated /黄铜镀金
  - 3.2 Outer Contact /外导体: Brass, Gold plated /黄铜镀金
  - 3.3 Insulators /绝缘体: PTFE /聚四氟乙烯

Suitable cables /适配电缆: RG316.RG174

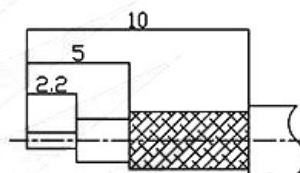
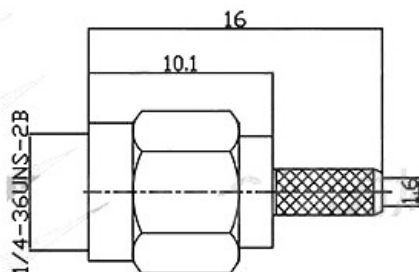

推荐剥线尺寸  
Recommended stripping size

产品型号P/N: SMA-C-J-1.5

# 产品规格书

## PRODUCT SPECIFICATION

This document contains proprietary information and such information may not be disclosed to others for any purposes,  
本文件包含专有信息，不得出于任何目的向他人披露此类信息。  
not used for sales/marketing/procurement purposes without written permission.  
未经书面许可，不得用于销售/营销/采购目的。

- 1..Electrical/电气
  - 1.1 Impedance /阻抗 50Ω
  - 1.2 Frequency /频率 DC-6GHz
  - 1.3 VSWR/驻波  $\leq 1.25$
  - 1.4 Dielectric withstanding voltage /介质耐压 500V(rms)
  - 1.5 Center contact resistance /中心接触电阻  $\leq 10m\Omega$
  - 1.6 Outer contact resistance /外部接触电阻  $\leq 5m\Omega$
  - 1.7 Insulation resistance /绝缘电阻  $\geq 1000M\Omega$

- 2 Environment & Mechanical /环境与机械
  - 2.1 Temperature range /温度范围  $-45^{\circ}\sim +125^{\circ}$
  - 2.2 Rohs Compliant /符合RoHS
  - 2.3 Durability /耐久性 500cycles

- 3 Material and Plating /材料和电镀
  - 3.1 Inner Contact /内导体: Brass, Gold plated /黄铜镀金
  - 3.2 Outer Contact /外导体: Brass, Gold plated /黄铜镀金
  - 3.3 Insulators /绝缘体: PTFE /聚四氟乙烯

Suitable cables /适配电缆: RG316.RG174

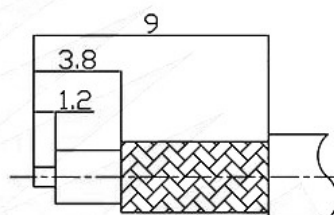
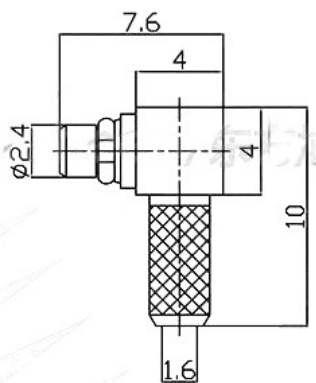

推荐剥线尺寸

产品型号P/N: MMCX-C-JW-1.5

# 射频连接线

跳线 延长线

MMCX-JW

MMCX弯公头



SMA-J

SMA公头



频率：0-6G

线缆：镀银RG316

直径：2.55mm

长度：可订做任意长度

