

勝特力材料 886-3-5753170
 勝特力电子(上海) 86-21-54151736
 勝特力电子(深圳) 86-755-83298787
[Http://www.100y.com.tw](http://www.100y.com.tw)

SMA3100S-0316

SMA Plug Crimp

50Ω

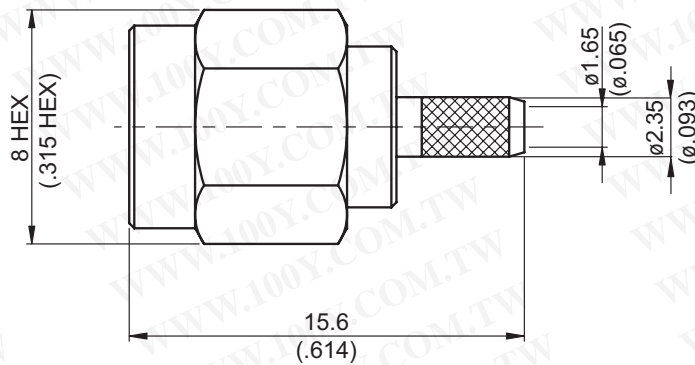

Parts	Material	Plating (Micro-inch)
Ferrule	Brass	Tin-Zinc-Copper-Alloy 100 Over Copper 50
Contact Pin	Brass	Gold 20 Over Nickel 50 Over Copper 50
Renber Ring	Beryllium Copper	Tin-Zinc-Copper-Alloy 100 Over Copper 50
Gasket	Silicon	
Insulator	Teflon	
Body	Stainless	Passivated
Coupling Nut	Stainless	Passivated

Weight: 2.98 g

Suitable Cables: RG174, RG188, RG316, RG316-E, RG316-FEP

This part number complies with RoHS.

CABLE ASSEMBLY INSTRUCTION

SMA3100S-0316

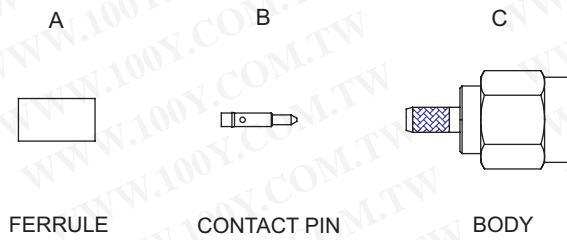

DIAGRAM	ASSEMBLY INSTRUCTION
	<p>Step 1: STRIP AS SHOWN.</p>
	<p>Step 2: SLIDE FERRULE "A" OVER CABLE. Step 3: PUT PIN "B" ON CENTER CONDUCTOR AND SOLDER IN "Y".</p>
	<p>Step 4: LOOSEN BRAIDING AND SLIDE CONNECTOR "C" IN PLACE.</p>
	<p>Step 5: SLIDE FERRULE "A" TOWARDS THE CONNECTOR "C" AND CRIMP.</p>

This part number complies with RoHS.