

勝特力材料 886-3-5753170
 勝特力电子(上海) 86-21-34970699
 勝特力电子(深圳) 86-755-83298787
 Http://www.100y.com.tw

- NOTES:
- MATERIALS:
 HOUSING: HIGH TEMPERATURE THERMOPLASTIC, UL94 V-0, COLOR:BLACK
 TAIL ALIGNER: HIGH TEMPERATURE THERMOPLASTIC,
 TERMINAL: HIGH PERFORMANCE COPPER ALLOY
 BRACKET: BRASS
 SHELL: STEEL
 INSERT: BRASS
 - FINISHES:
 TERMINAL: 0.05-0.25 MICROMETERS GOLD FLASH IN CRITICAL AREA
 OVER 0.75 MICROMETERS MINIMUM PALLADIUM NICKEL IN
 CRITICAL AREA. 1.87 MICROMETERS MINIMUM TIN IN
 SOLDER TAIL AREA OVER 1.25 MICROMETERS MINIMUM NICKEL.
 BRACKET: 5.0 MICROMETERS BRIGHT TIN OVER 2.50 MICROMETERS COPPER.
 SHIELD: 3.8 MICROMETERS MINIMUM BRIGHT TIN OVER 1.3 MICROMETERS
 MINIMUM NICKEL OVER COPPER FLASH (OPTIONAL).
 INSERT: 2.54 MICROMETERS MINIMUM NICKEL.
 - PART PERFORMS TO MOLEX PRODUCT SPECIFICATION
 PS-71425-9999.
 - PACKAGE PER PK-70873-0823.
 - APPLICABLE STANDARDS: EIA-3652 AND SFF-8441.
 - DATE CODE: YR/WK PER EIA-476-A.
 - PRODUCT COMPLIES WITH COSMETIC SPECIFICATION PS-45499-002.
 SEE SIDE VIEW FOR SURFACE CLASSIFICATIONS.
 - TORQUE TO INSTALL SCREWLOCKS INTO THREADED INSERTS:
 0.34 Nm MAXIMUM.

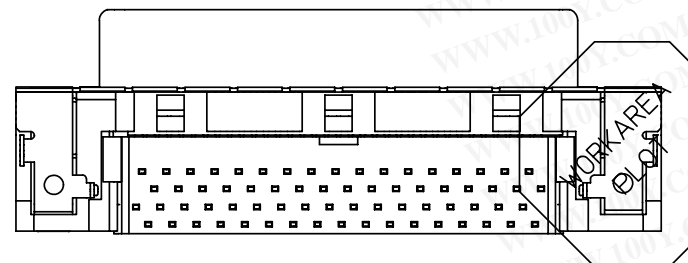
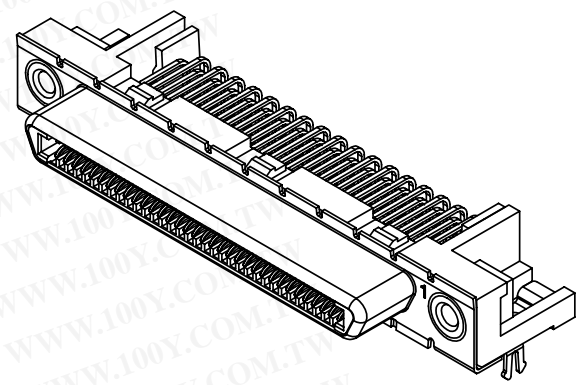
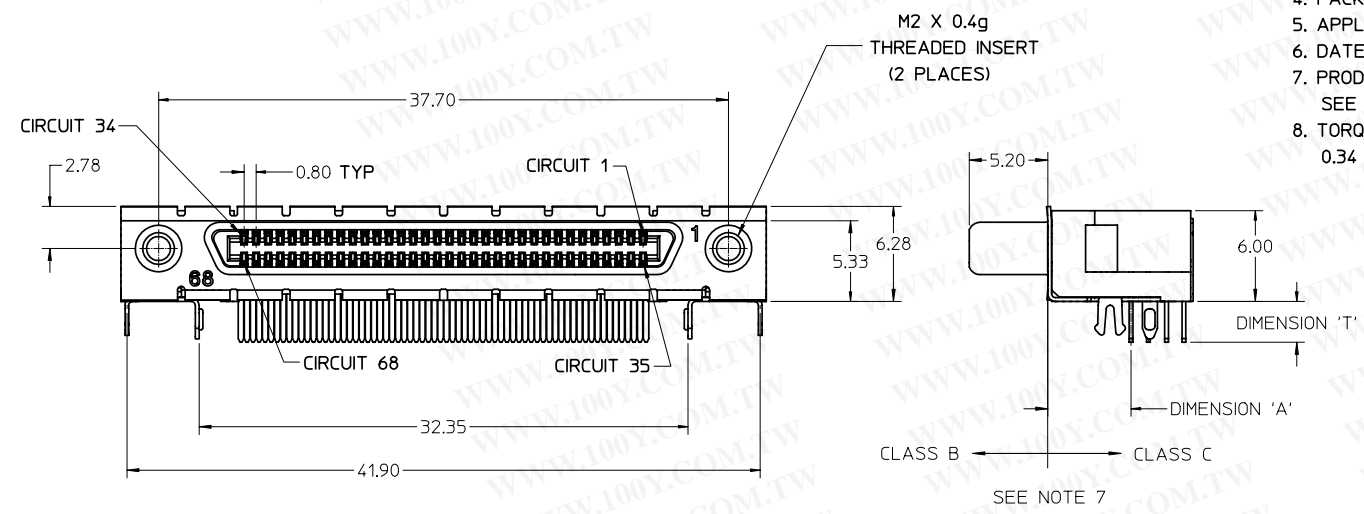
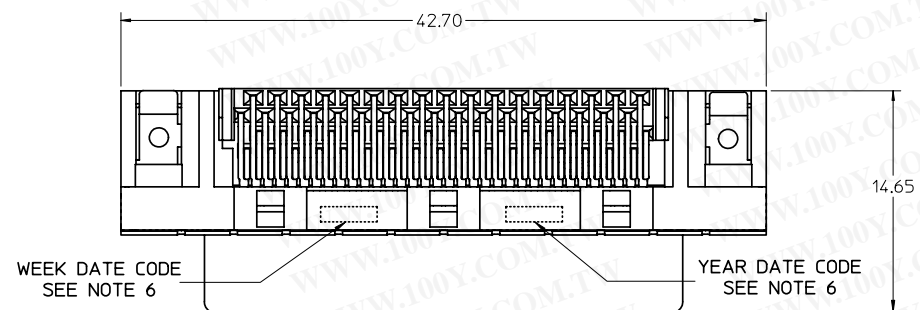

ADD -0012 AND -0013 EC NO: DRWN:BBARKER 2007/07/12 CHKD:DMORGAN APPR:	QUALITY SYMBOLS ▽ 0 ∇ 0	GENERAL TOLERANCES (UNLESS SPECIFIED)		SCALE 4:1	DESIGN UNITS METRIC	THIRD ANGLE PROJECTION REVISIONS: REVISE ON CAD ONLY	
		mm	INCH	DIMENSION STYLE MM ONLY			TITLE
		4 PLACES ±---	±---	DRAWN BY KSTILES	DATE 11/14/2002	MOLEX INCORPORATED SEE CHART SD-71430-015	
		3 PLACES ±---	±---	CHECKED BY KSTILES	DATE 11/15/2002		
2 PLACES ±0.13	±---	DRAFT WHERE APPLICABLE		APPROVED BY MBNAKIS	DATE 11/22/2002	MATERIAL NO. SEE CHART	
1 PLACE ±0.25	±---	MUST REMAIN WITHIN DIMENSIONS		DOCUMENT NO. SD-71430-015	SHEET NO. 1 OF 3		
				THIS DRAWING CONTAINS INFORMATION THAT IS PROPRIETARY TO MOLEX INCORPORATED AND SHOULD NOT BE USED WITHOUT WRITTEN PERMISSION			

PCB THICKNESS	PART NUMBER	TAIL LENGTH 'T'	ENHANCED GROUND TABS	SCREWLOCKS	TAIL LOC. 'A'	HOLE LOCATION 'B'
1.60	71430-0101	2.08	NO	NONE	5.50	6.50 MAXIMUM
1.60	71430-0007	2.08	NO	LOOSE IN BAGS		
1.60	71430-0005	2.08	YES	NONE		
1.60	71430-0008	2.08	YES	LOOSE IN BAGS		
2.36	71430-0268	2.71	NO	NONE		
2.36	71430-0006	2.71	NO	INSTALLED		
2.36	71430-0004	2.71	YES	NONE		
2.36	71430-0009	2.71	YES	INSTALLED		
2.36	71430-0016	2.71	NO	LOOSE IN BAGS		
2.36	71430-0019	2.71	YES	LOOSE IN BAGS		
2.36	71430-0012	2.71	YES	NONE	5.30	6.30 MAXIMUM
1.60	71430-0013	2.08	YES	NONE		

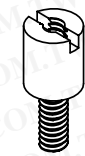
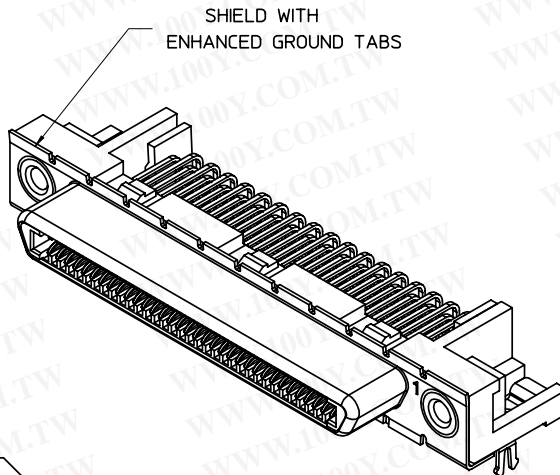
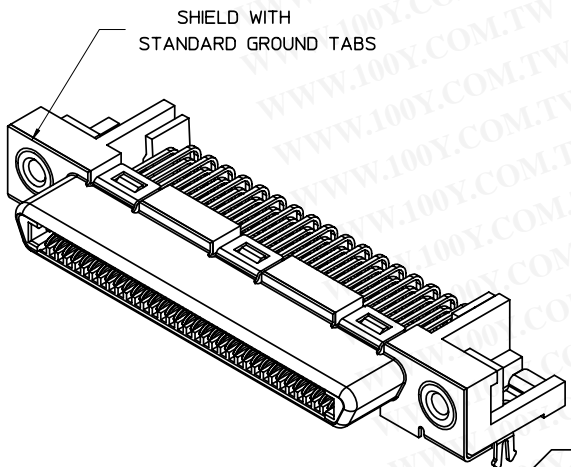

OPTIONAL SCREWLOCK
PART NUMBER 71433-0002

WORKAREA PLOT

ADD -0012 AND -0013 EC NO: DRWIN:BBARKER 2007/07/12 CHKD:DMORGAN APPR:	QUALITY SYMBOLS ▽ 0 ∇ 0	GENERAL TOLERANCES (UNLESS SPECIFIED)		SCALE 4:1	DESIGN UNITS METRIC	THIRD ANGLE PROJECTION REVISE ON CAD ONLY	
		mm	INCH	DIMENSION STYLE MM ONLY			
		4 PLACES ±---	±---	DRAWN BY KSTILES	DATE 11/14/2002	TITLE VHDCI RIGHT ANGLE ASSEMBLY	
		3 PLACES ±---	±---	CHECKED BY KSTILES	DATE 11/15/2002		
2 PLACES ±0.13	±---	DRAFT WHERE APPLICABLE		MOLEX INCORPORATED SEE CHART SD-71430-015			
1 PLACE ±0.25	±---	MUST REMAIN WITHIN DIMENSIONS		APPROVED BY MBNAKIS	DATE 11/22/2002	MATERIAL NO. SHEET NO. 2 OF 3	
THIS DRAWING CONTAINS INFORMATION THAT IS PROPRIETARY TO MOLEX INCORPORATED AND SHOULD NOT BE USED WITHOUT WRITTEN PERMISSION							

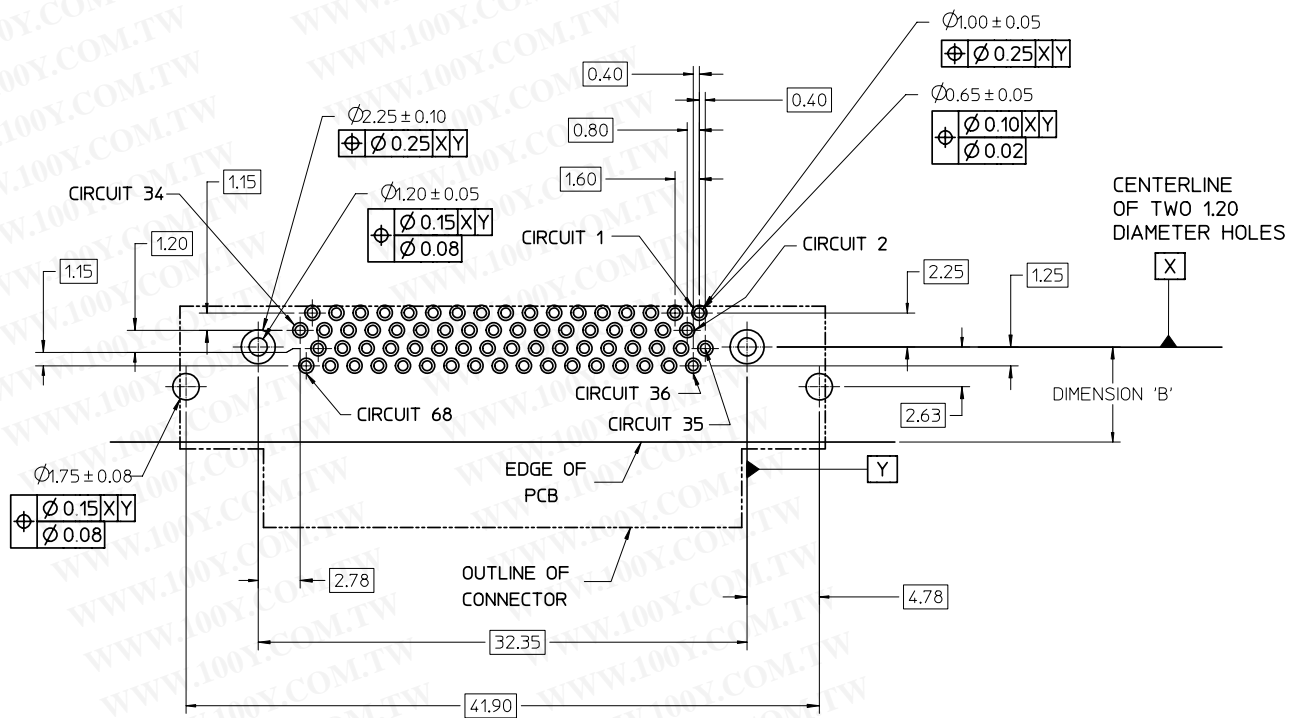

NOTES:

1. FOR FULL MATE WITH PLUG, PANEL THICKNESS SHOULD NOT EXCEED 1.0mm.

FUNCTIONAL MATING WITH MOLEX PLUG CAN STILL BE MAINTAINED WITH PANELS AS THICK AS 2.5mm (BUT PLUG AND RECEPTACLE WILL NOT BE FULLY MATED).

2. GUIDELINES FOR CHOOSING A MOLEX SCREWLOCK:

PANEL THICKNESS	RECOMMENDED SCREWLOCK
LESS THAN OR EQUAL TO 1.00 MM	71433-0002
1.01 TO 2.15 MM	71433-0010

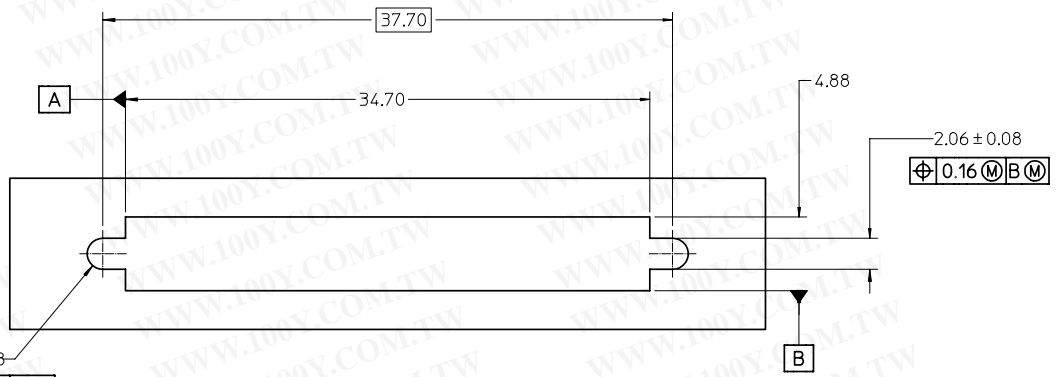

WORKAREA PLOT

INCREASE REV LEVEL EC NO: DRWN:BBARKER 2007/07/12 CHKD:DMORGAN APPR:	QUALITY SYMBOLS ▼ - 0 ∇ - 0	GENERAL TOLERANCES (UNLESS SPECIFIED) mm INCH 4 PLACES ± --- ± --- 3 PLACES ± --- ± --- 2 PLACES ± 0.13 ± --- 1 PLACE ± 0.25 ± --- ANGULAR ± 1/2°	SCALE 4:1 DESIGN UNITS METRIC DIMENSION STYLE MM ONLY	THIRD ANGLE PROJECTION REVISIONS REV 1
	DRAFT WHERE APPLICABLE MUST REMAIN WITHIN DIMENSIONS	DRAWN BY DATE KSTILES 11/14/2002 CHECKED BY DATE KSTILES 11/15/2002 APPROVED BY DATE MBNAKIS 11/22/2002	TITLE VHDCI RIGHT ANGLE ASSEMBLY	MATERIAL NO. DOCUMENT NO. SHEET NO. SEE CHART SD-71430-015 3 OF 3
	THIS DRAWING CONTAINS INFORMATION THAT IS PROPRIETARY TO MOLEX INCORPORATED AND SHOULD NOT BE USED WITHOUT WRITTEN PERMISSION	MOLEX INCORPORATED	MOLEX INCORPORATED	MOLEX INCORPORATED
	INCREASE REV LEVEL	INCREASE REV LEVEL	INCREASE REV LEVEL	INCREASE REV LEVEL