



RoHS
Ready 

AMP Circular Connectors for Commercial Signal & Power Applications

勝特力材料 886-3-5753170
勝特力电子(上海) 86-21-34970699
勝特力电子(深圳) 86-755-83298787
[Http://www.100y.com.tw](http://www.100y.com.tw)

 **Tyco Electronics**
Our commitment. Your advantage.

Note: All part numbers are RoHS Compliant.

CPC Connector Accessories

Cable Clamps

Cable clamps provide strain relief and can be used on all series receptacles and plugs.

Material

Black thermoplastic heat-stabilized, fire-resistant, self-extinguishing, UL 94V-0 rated

Standard Size

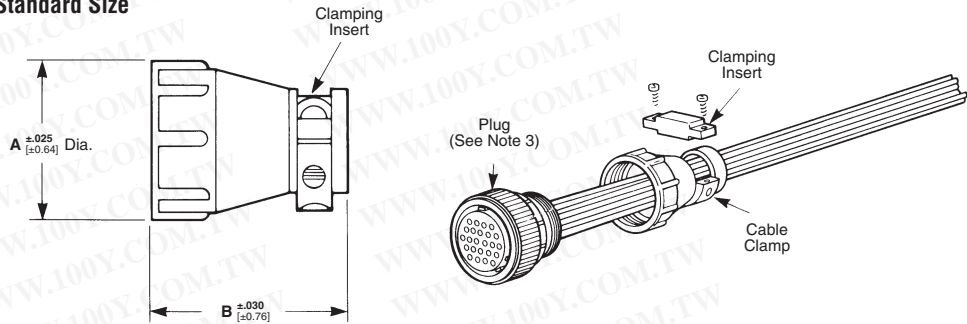

| Shell Size | Dimensions | | Cable O.D. (Max.) | Thread Size | Part No. | |
|------------|----------------|----------------|-------------------|------------------|-----------------------|-----------------------|
| | A | B | | | Individually Packaged | Bulk Packaged* |
| 11 | .825 20.96 | 1.250 31.75 | .329 8.36 | 5/8-24 UNEF-2B | 1-206062-4 | 1-206062-7** (400) |
| 13 | .950 24.13 | 1.400 35.56 | .453 11.51 | 3/4-20 UNEF-2B | 206966-7 | 206966-9** (200) |
| 17 | 1.125 28.58 | 1.400 35.56 | .453 11.51 | 15/16-20 UNEF-2B | 206070-8 | 1-206070-0** (200) |
| 23 | 1.600 40.64 | 1.555 39.5 | .703 17.86 | 1-3/8-18 UNEF-2B | 206138-8 | 1-206138-0** (100) |

*Numbers in parentheses specify, in multiples, the minimum quantity of parts that can be ordered.
 **Packaging includes two screws: shell sizes 11-17, screw length .500 [12.7]; shell size 23, screw length .625 [15.88].
Notes: 1. Clamping areas adjustable by inverting or changing clamping inserts. The quantity of inserts supplied with each assembly is as follows: for size 11 cable clamps, one insert; for all other cable clamps, two inserts.
 2. Components for all cable clamps are packaged unassembled. This includes the cable clamp, two screws and the clamping inserts.
Notes: 3. Cable clamps can be threaded directly onto plugs or receptacles, or onto back-shell extenders (page 40).
 4. Replacement screws are available in the following sizes: 3/8 in. [9.52]—**5019024-1**, 1/2 in. [12.7]—**5019024-2**, 5/8 in. [15.88]—**5019024-3**, 1 in. [25.4]—**5019024-4**, 3/4 in. [19.05]—**5019024-5**.
 5. Cable clamp inserts not sold separately.

Large Size

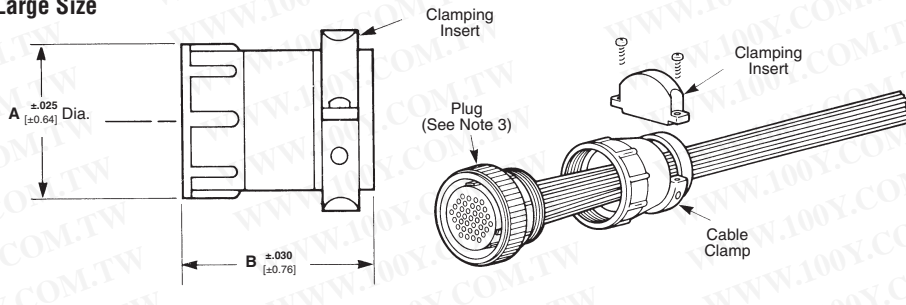

| Shell Size | Dimensions | | Cable O.D. (Max.) | Thread Size | Part No. | |
|------------|----------------|----------------|-------------------|------------------|-----------------------|-----------------------|
| | A | B | | | Individually Packaged | Bulk Packaged* |
| 11 | .850 21.59 | 1.450 36.83 | .453 11.51 | 5/8-24 UNEF-2B | 206358-5 | 206358-6** (200) |
| 13 | 1.131 28.73 | 1.655 42.04 | .703 17.86 | 3/4-20 UNEF-2B | 207008-5 | 207008-6** (100) |
| 17 | 1.131 28.73 | 1.655 42.04 | .703 17.86 | 15/16-20 UNEF-2B | 206322-9 | 1-206322-0** (100) |
| 23 | 1.600 40.64 | 1.655 42.04 | 1.125 28.58 | 1-3/8-18 UNEF-2B | 206512-5 | 206512-6** (75) |

*Numbers in parentheses specify, in multiples, the minimum quantity of parts that can be ordered.
 **Packaging includes two screws: shell size 11, screw length .500 [12.7]; shell sizes 13-23, screw length .625 [15.88].
Notes: 1. Clamping areas adjustable by inverting or changing clamping inserts. The quantity of inserts supplied with each assembly is as follows: for size 23 cable clamps, four inserts; for all other cable clamps, two inserts.
 2. Components for all cable clamps are packaged unassembled. This includes the cable clamp, two screws and the clamping inserts.
Notes: 3. Cable clamps can be threaded directly onto plugs or receptacles, or onto back-shell extenders (page 40).
 4. Replacement screws are available in the following sizes: 3/8 in. [9.52]—**5019024-1**, 1/2 in. [12.7]—**5019024-2**, 5/8 in. [15.88]—**5019024-3**, 1 in. [25.4]—**5019024-4**, 3/4 in. [19.05]—**5019024-5**.
 5. Cable clamp inserts not sold separately.

勝特力材料 886-3-5753170
 勝特力电子(上海) 86-21-34970699
 勝特力电子(深圳) 86-755-83298787
 Http://www.100y.com.tw

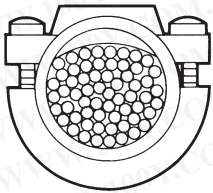

The clamping area can be adjusted by reversing the clamping insert as shown below.

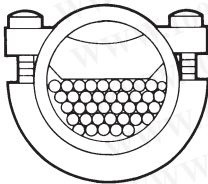

For additional information concerning cable clamps, refer to Instruction Sheet 408-7582.

Note: All part numbers are RoHS Compliant.

CPC Connector Accessories (Continued)

Self-Centering Cable Clamp (for Shell Size 23)

The self-centering cable clamp is used in applications where strain relief protection is required and the cable or wire bundle is large and/or stiff.

Material

Black thermoplastic, UL 94V-0 rated

Part Numbers

207774-3 (individually packaged)

207774-4 (bulk packaged)

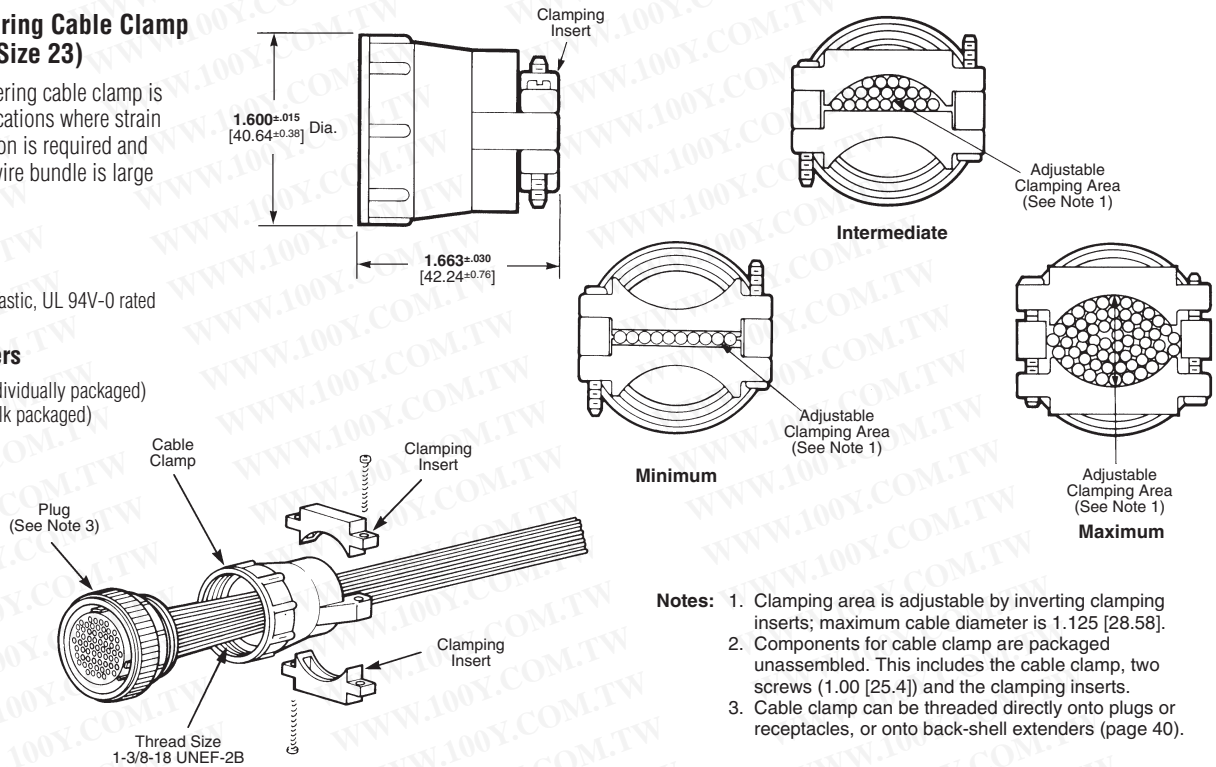

- Notes:**
1. Clamping area is adjustable by inverting clamping inserts; maximum cable diameter is 1.125 [28.58].
 2. Components for cable clamp are packaged unassembled. This includes the cable clamp, two screws (1.00 [25.4]) and the clamping inserts.
 3. Cable clamp can be threaded directly onto plugs or receptacles, or onto back-shell extenders (page 40).

Right-Angle Cable Clamps

Right-angle cable clamps are used in tight areas where typical 180° cable clamp strain reliefs will not fit.

Material

Black thermoplastic, UL 94V-0 rated

Related Product Data

Technical Documents — page 80

Style A Kit

Kit w/Cover

Style B

Part Number 213982-1 (for Shell Size 13)

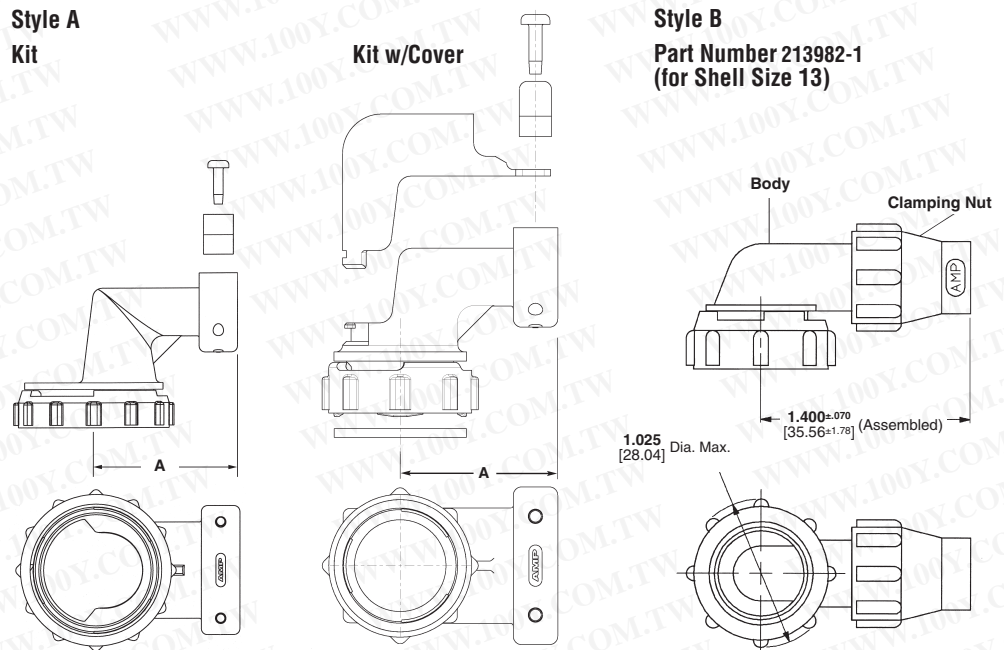

| Shell Size | Dim. A | Cable O.D. Max. | Coupling Ring Thread Size | Part Number | |
|------------|---------------|-----------------|---------------------------|-------------|-------------|
| | | | | Kit | Kit w/Cover |
| 11 | .900 [22.86] | .329 [8.36] | 5/8-24 UNEF-2B | 796379-2 | 1546347-2 |
| 13 | 1.100 [27.94] | .453 [11.51] | 3/4-20 UNEF-2B | 796380-2 | 1546348-2 |
| 17 | 1.200 [30.48] | .453 [11.51] | 15/16-20 UNEF-2B | 796381-2 | 1546349-2 |
| 23 | 1.500 [38.10] | .703 [17.86] | 1-3/8-18 UNEF-2B | 796382-2 | 1546350-2 |

勝特力材料 886-3-5753170
 勝特力电子(上海) 86-21-34970699
 勝特力电子(深圳) 86-755-83298787
[Http://www.100y.com.tw](http://www.100y.com.tw)