



Turned crimp contacts

Identification	Wire gauge (mm ²)	Part No.		
		Male contacts	Female contacts	High-end female contacts
		Performance level 1*	Performance level 1*	Performance level 1*
Individual contacts ¹⁾	AWG 22-18 0.33-0.82	09 67 000 3576	09 67 000 3476	09 67 000 3676
	AWG 24-20 0.25-0.52	09 67 000 8576	09 67 000 8476	09 67 000 8676
	AWG 26-22 0.13-0.33	09 67 000 5576	09 67 000 5476	09 67 000 5676
	AWG 28-24 0.09-0.25	09 67 000 7576	09 67 000 7476	09 67 000 7676

¹⁾ Minimum order 100 pieces or multiples of 100

Male contacts

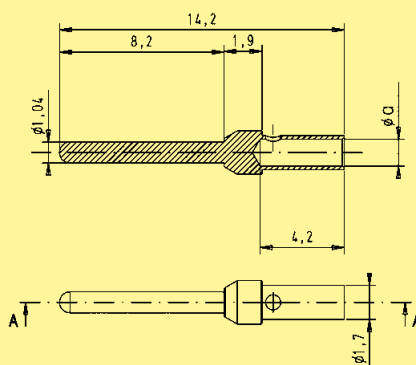

	a	groove
AWG 22-18	1.34	none
AWG 24-20	1.13	1
AWG 26-22	0.88	2
AWG 28-24	0.64	3

Female contacts

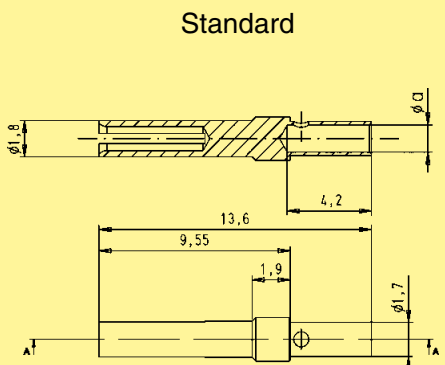

Standard

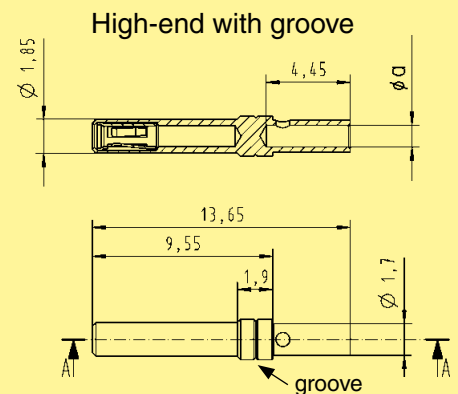

High-end with groove

* Performance level 1 as per CECC 75 301-802, 500 mating cycles, 10 days 4 mixed gas test – IEC 60 512
 Use crimp tool with the part no. 09 99 000 0501 and the locator with the part no. 09 99 000 0531. Details see chapter 20

1 2 3 4 5 6

A

B

C

D

A-A

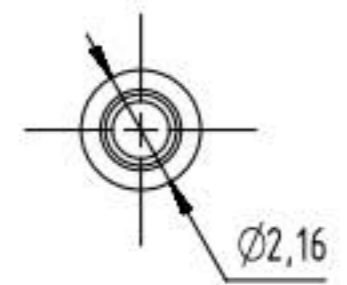
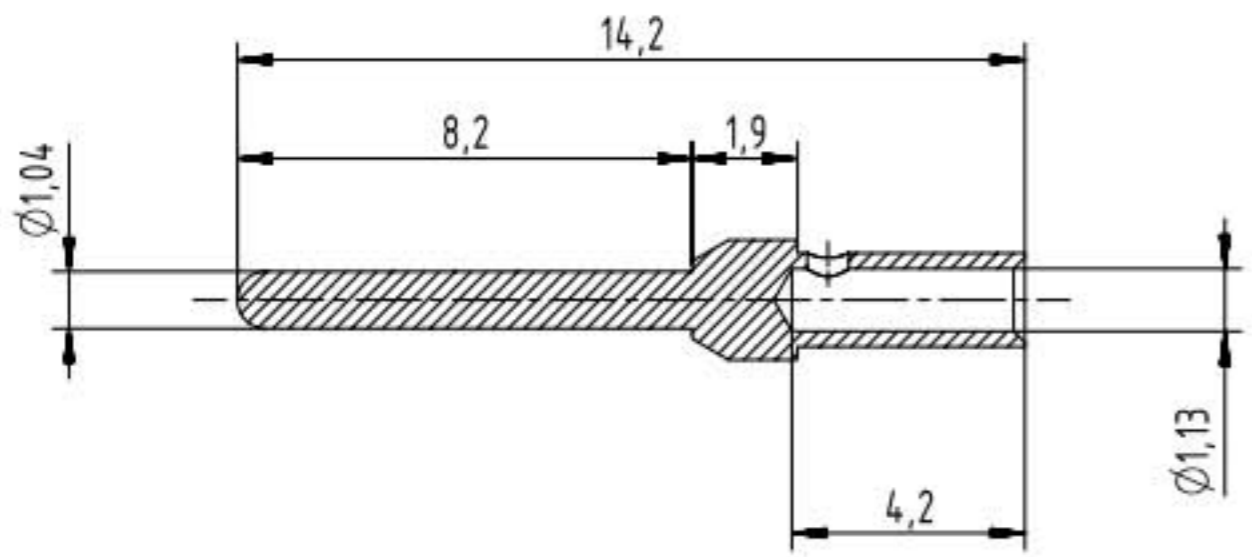

Crimping of AWG 20-24:

hand tool: 09 99 000 0501
locator: 09 99 000 0531

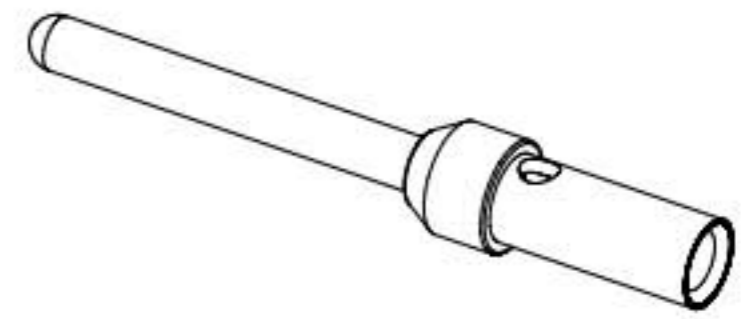
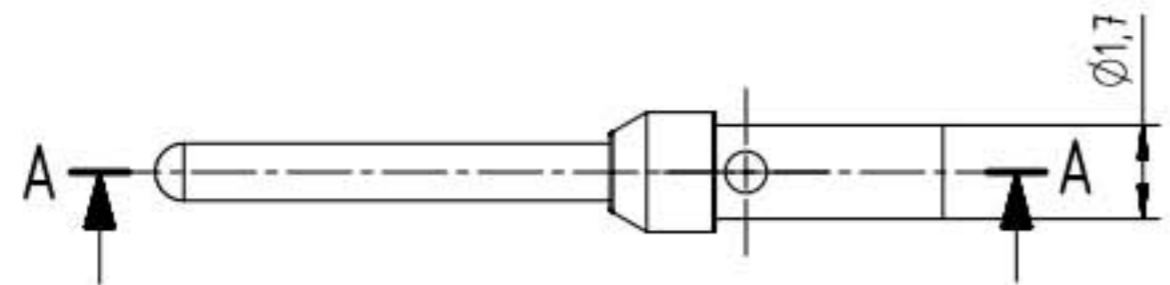

	All Dimensions in mm Original Size DIN A4		Scale 5:1	Free size tol.		Ref.	
	All rights reserved		Created by BOURGEOIS	Inspected by BAGDIKIAN	Standardisation KOHLER	Date 2014-06-18	State Final Release
Department EC PD - FR		Title D-Sub, MA AWG 20-24 crimp cont				Doc-Key / ECM-Nr. 100562538/UGD/001/8 500000076079	
HARTING Electronics GmbH D-32339 Espelkamp		Type TB Number 09670008576				Rev. B Page 1/1	

09 67 000 8576 580	PL1	5000
09 67 000 8576	PL1	100
Part number	Gold plating (over nickel)	Bulk packaging