



00 NIM-CAMAC & 01 COAXIAL CONNECTORS

00
&
01
SERIES

勝特力材料 886-3-5753170
勝特力电子(上海) 86-21-34970699
勝特力电子(深圳) 86-755-83298787
[Http://www.100y.com.tw](http://www.100y.com.tw)

 **LEMO**

勝特力材料 886-3-5753170
勝特力电子(上海) 86-21-34970699
勝特力电子(深圳) 86-755-83298787
[Http://www.100y.com.tw](http://www.100y.com.tw)



LEMO coaxial 00 and 01 Series (50 Ω)

Fundamental research in particle physics as practised within CERN and other nuclear research establishments requires more and more complex equipment of high performance in order to achieve the objectives. The needs of such research contribute to the development of leading products for the whole of industry. For many years LEMO has participated in this evolution. This has resulted in a range of miniature coaxial connectors (50 Ω) with a push-pull self-latching system, the LEMO 00.250 series. These connectors now form the basis of the NIM-CAMAC CD/N 549 standard.

The plugs and sockets of the 01 series are amongst the smallest available 50 Ω coaxial connectors with a self-latching intermating capability. In spite of their small size and light weight, their technical characteristics remain excellent. Available in a wide range of housing configurations, they are especially useful when connecting onto printed circuit boards.

The LEMO 00 series and 01 are now used in many areas such as: telecommunications, sensors, medical equipment, space research, etc...

The program covered in this catalog now includes more than 50 models suitable for many cable types.

Table of Contents

2 steps to select the right connector	3
00.250 (NIM-CAMAC CD/N 549) Series	
Part numbering system	7
Metal housing models	8
Plastic housing models	21
Watertight or vacuumtight models	22
Metal housing models with mechanical keying	24
Threaded-latching models	26
Adaptors	27
Variant	30
Assembled cables	31
Accessories	31
Spare parts	33
Tooling	35
Panel cut-outs	37
Cable assembly	38
01.250 (Minax) Series	
Part numbering system	45
Metal housing models	46
Threaded-latching models	50
Adaptors	50
Spare parts	51
Tooling	52
Panel cut-outs	53
Cable assembly	53
Technical characteristics	
Outer shell	55
Insulator	56
Electrical contact	56
Cable fixing	58
Technical tables (VSWR)	58
Product safety notice	59

勝特力材料 886-3-5753170
 勝特力电子(上海) 86-21-34970699
 勝特力电子(深圳) 86-755-83298787
[Http://www.100y.com.tw](http://www.100y.com.tw)

Precision modular connectors to suit your application

Since its creation in Switzerland in 1946 the LEMO Group has been recognized as a global leader of circular Push-Pull connectors and connector solutions. Today LEMO and its affiliated companies, REDEL and COELVER, are active in more than 80 countries with the help of over 40 subsidiaries and distributors.

Over 50'000 connectors

The modular design of the LEMO range provides over 50'000 connectors from miniature \varnothing 3 mm to \varnothing 50 mm, capable of handling cable diameters up to 30 mm and for up to 106 contacts.

This vast portfolio enables you to select the ideal connector configuration to suit almost any specific requirement in most markets, including medical devices, test and measurement instruments, machinery, audio video broadcast, telecommunications and military.

LEMO's Push-Pull Self-Latching Connection System

This self-latching system is renowned worldwide for its easy and quick mating and unmating features. It provides absolute security against vibration, shock or pull on the cable, and facilitates operation in a very limited space.

The LEMO self-latching system allows the connector to be mated by simply pushing the plug axially into the socket.

	Series	
Force	00	01
Fv	9N	5N

Fv: average latching force

Once firmly latched, connection cannot be broken by pulling on the cable or any other component other than the outer release sleeve.

	Series	
Force	00	01
Fa	120N	110N

Fa: average pull force with axial pull on the collet nut

When required, the connector is disengaged by a single axial pull on the outer release sleeve. This first disengages the latches and then withdraws the plug from the socket.

	Series	
Force	00	01
Fd	7N	6N

Fd: average unmating force with axial pull on the outer release sleeve.

1N = 0,102 kg.

Force measured according to the standard IEC 60512- test

UL Recognition

LEMO connectors are recognized by the Underwriters Laboratories (UL), file E119802. The approval of the overall electrical system (LEMO connector, cable and your equipment) will be easier because of LEMO connectors recognition.

CE marking

When used according to the protection requirements of the European safety directives, LEMO connectors are designed to comply with equipment bearing CE marking.

RoHS

LEMO connectors are in compliance with the RoHS directives (2002/95/EC) of the European Parliament. This directive specifies the restrictions of the use of the above-mentioned hazardous substances in electrical and electronic equipment marketed in Europe. LEMO guarantees that its connectors are free of mercury, cadmium, lead, hexavalent chromium and polybromide biphenyl (PBB) or polybromide diphenyl ether (PBDE).

2 steps to select the right connector

● Step 1: Select connector series

Select the appropriate LEMO connector series according to the standard, the cable, according to the application or the mated connector already on your equipment.

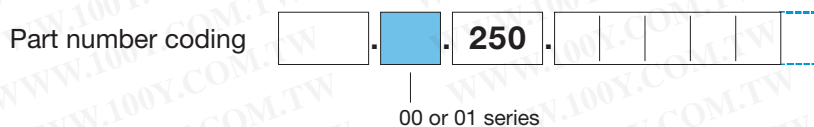

The NIM-CAMAC 00.250 series

The 00 series is coaxial (50 Ω). This connectors family was conceived for all applications where a high density of connectors is necessary, especially for patch panels. Because of LEMO's special self-latching system, it is possible to connect them with a simple axial push-pull thereby reducing the space needed to mount sockets to an absolute minimum, up to 50 sockets per square decimetre. LEMO 00 connectors served as the norm for NIM-CAMAC CD/N549 standard, used in nuclear physics as well as many other applications.

The miniature 01.250 series

The 01 series is coaxial (50 Ω). The plugs and sockets are amongst the smallest available 50 Ω coax connectors with a self-latching intermating capability. In spite of their small size and light weight, their technical characteristics remain excellent. Available in a wide range of housing configurations, they are especially useful when connecting onto printed circuit boards.

勝特力材料 886-3-5753170
 勝特力电子(上海) 86-21-34970699
 勝特力电子(深圳) 86-755-83298787
[Http://www.100y.com.tw](http://www.100y.com.tw)

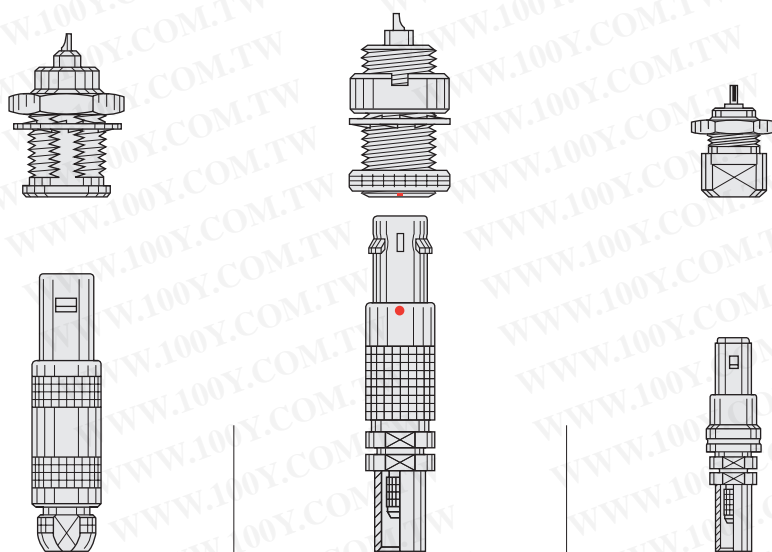

	00	00	01
Series	00	00	01
Standard	NIM-CAMAC	-	-
Environment	indoor	indoor	indoor
Ingress Protection ¹⁾	IP50	IP50	IP50
Ingress Protection ²⁾	IP64	IP50	IP64
Temperature range	- 55 to 260°C	- 55 to 260°C	- 55 to 230°C
Keying	-	Yes	-
Latching	Push-Pull self-latching		
Contact type	Solder, crimp or print	Solder, crimp or print	Solder or print
Cable fixing type	Clamping or crimping	Crimping	Crimping

Note: ¹⁾ IP50 = Protection from the amount of dust that would interfere with the operation of the equipment
²⁾ Ingress protection between LEMO socket and your device (IP64 = protection from splashed water and dust tight)

Step 2: Complete the part number

Complete the part numbering by choosing the model depending on your cable and the application.

Part number coding . . **250** .

Verify the fitting to your cable and cable wire

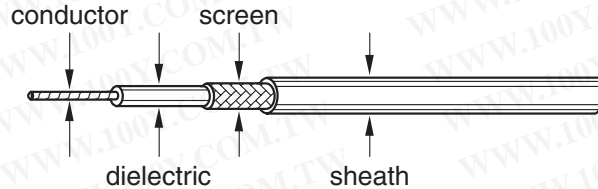

勝特力材料 886-3-5753170
 勝特力电子(上海) 86-21-34970699
 勝特力电子(深圳) 86-755-83298787
[Http://www.100y.com.tw](http://www.100y.com.tw)

Recommended coaxial cables

Electrical and general properties

	MIL-C-17	IEC 60096-2	CCTU 10-01A	LEMO Part-No	LEMO Cable group	Impedance	Capacitance	Attenuation	Operating voltage	Temperature °C		Series	
						Ohm	pF/m	db/100 m at 100 MHz	U max. KV eff.	from	to	00	01
Standard	RG 58 C/U	50.3.1	KX 15	CCX.50.RG5.8CU50N	6	50 ± 2	101	23	1.90	-25	+70	•	
	RG 142 B/U			CCX.50.RG1.42BU50M	7	50 ± 2	95	12.8	1.50	-70	+200	•	
	RG 174 /U	50.2.1	KX 38	CCX.50.RG1.74U25N	3	50 ± 2	101	35	2.50	-40	+75	•	•
	RG 174 A/U	50.2.1	KX 3A	CCX.50.RG1.74AU27N	3	50 ± 2	101	31.5	1.50	-25	+70	•	•
	RG 178 B/U	50.1.1	KX 21A	CCX.50.RG1.78BU18M	1	50 ± 2	96	48	0.70	-90	+205	•	•
	RG 179 B/U	75.2.1		CCX.75.RG1.79BU26M	2	75 ± 3	64	33	1.20	-90	+205	•	•
	RG 187 A/U	75.2.2		CCX.75.RG1.87AU26B	2	75 ± 3	64	33	1.20	-50	+205	•	•
	RG 188 A/U	50.2.3		CCX.50.RG1.88AU24B	4	50 ± 2	96	33	1.20	-50	+205	•	•
	RG 195 A/U			CCX.95.RG1.95AU37B	5	95 ± 5	49	17	1.50	-90	+205	•	•
	RG 196 A/U	50.1.2		CCX.50.RG1.96AU20B	1	50 ± 2	96	48	0.70	-50	+205	•	•
RG 316 /U	50.2.2	KX 22A	CCX.50.RG3.16U26M	4	50 ± 2	96	33	1.20	-90	+205	•	•	
Non standard	Huber+Suhner	G02232D-60			8	50 ± 2	101	24	1.50	-40	+105	•	
	Huber+Suhner	K01152-07			9	50 ± 5	96	72	0.45	-45	+165	•	
	Storm	421-099			8	50 ± 2	96	72	2.50	-40	+75	•	

Mechanical properties

	Type	Conductor			Dielectric		Screen		Sheath			Weight kg/100m.
		Mat.	Stranding	ø mm	Mat.	ø mm	Mat.	ø mm	Mat.	Colour	ø mm	
Standard	RG 58 C/U	CuSn	19 x 0.18	0.90	PE	2.92	CuSn	3.6	PVC	black	4.95	3.80
	RG 142 B/U	CuStAg	solid	0.95	PTFE	2.95	CuAg CuAg	1 st : 3.53 2 nd : 4.20	FEP		4.95	6.60
	RG 174 U	CuSt	7 x 0.16	0.48	PE	1.50	CuSn	2.0	PVC1	black	2.55	
	RG 174 A/U	CuSt	7 x 0.16	0.48	PE	1.50	CuSn	2.0	PVC2	black	2.80	1.10
	RG 178 B/U	CuStAg	7 x 0.10	0.30	PTFE	0.87	CuAg	1.4	FEP	brown	1.80	0.85
	RG 179 B/U	CuStAg	7 x 0.10	0.30	PTFE	1.50	CuAg	2.0	FEP	brown	2.60	1.50
	RG 187 A/U	CuStAg	7 x 0.10	0.30	PTFE	1.50	CuAg	2.0	PFA	white	2.60	1.60
	RG 188 A/U	CuStAg	7 x 0.18	0.54	PTFE	1.50	CuAg	2.0	PFA	white	2.60	1.60
	RG 195 A/U	CuStAg	7 x 0.10	0.30	PTFE	2.52	CuAg	3.1	PFA	white	3.70	2.80
	RG 196 A/U	CuStAg	7 x 0.10	0.30	PTFE	0.87	CuAg	1.37	PFA	white	2.00	1.10
RG 316 /U	CuStAg	7 x 0.18	0.54	PTFE	1.50	CuAg	2.1	FEP	brown	2.60	1.60	
Non standard	G02232D-60	Cu	7 x 0.16	0.50	PE	1.50	CuAg CuSn	1 st : 1.95 2 nd : 2.40	PVC	grey	3.10	2.10
	K01152-07	CuAg	7 x 0.06	0.19	PFA	0.52	CuAg	0.9	PFA	white	1.25	0.90
	421-099	CuStAg	7 x 0.16	0.50	PTFE	1.52	CuAg CuAg	1 st : 2.00 2 nd : 2.50	FEP		3.05	1.95

勝特力材料 886-3-5753170
勝特力电子(上海) 86-21-34970699
勝特力电子(深圳) 86-755-83298787
[Http://www.100y.com.tw](http://www.100y.com.tw)

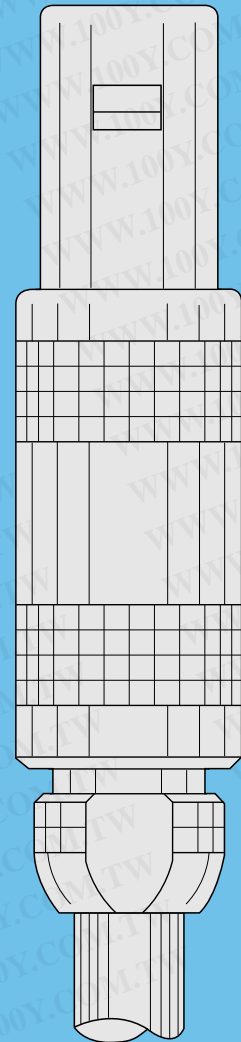
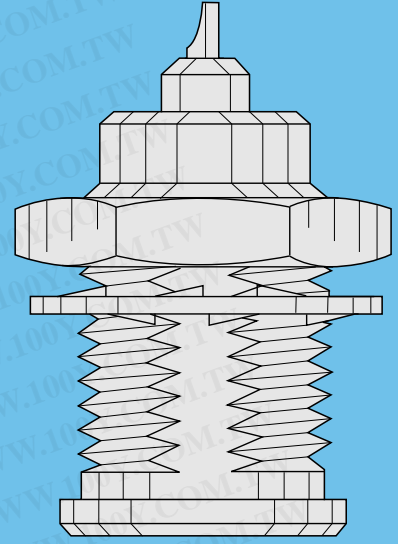

00 SERIES (NIM-CAMAC)

00 Series (NIM-CAMAC CD/N 549)

The 00 series is a range of 50 Ω coaxial connectors. They are suitable for a wide variety of applications particularly in measurement, control system and nuclear physics, having formed the basis for the NIM-CAMAC CD/N 549 standard. LEMO 00 connectors offer customers many benefits including:

- Self-latching push-pull system
- Aesthetically pleasing appearance
- Small size
- High packing density
- Rugged construction
- Ease of use
- Low weight
- Reliable performances
- Wide choice to suit application

Metal housing models (page 8)

Fixed plugs

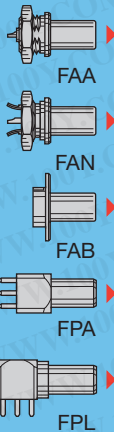

Straight plugs

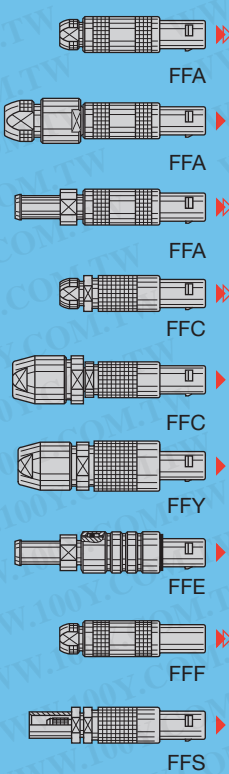

Fixed sockets

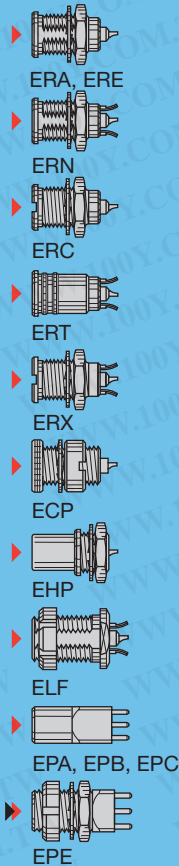

Elbow sockets

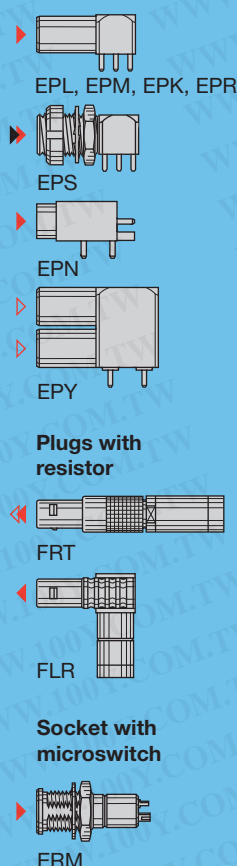

Free sockets

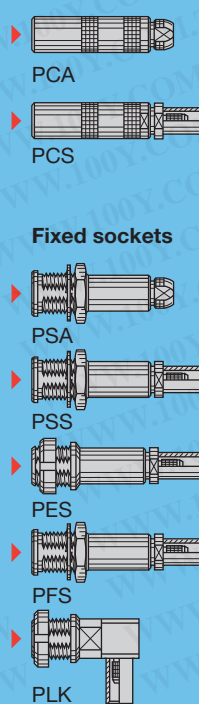

Fixed coupler

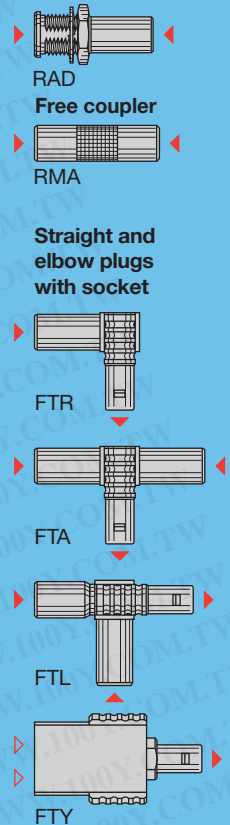

Plastic housing models* (page 21)

Straight plug

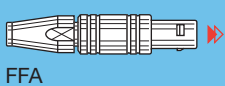

Fixed socket

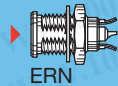

Threaded latching models* (page 26)

Straight plug

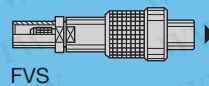

Adaptors

(See page 27)

Watertight or vacuumtight models (page 22)

Straight sockets

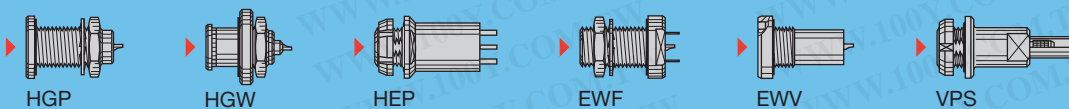

Straight coupler

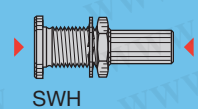

Metal housing models with mechanical keying* (page 24)

Straight plug



Elbow sockets



Fixed sockets



* not included in NIM-CAMAC standard

Part Numbering System

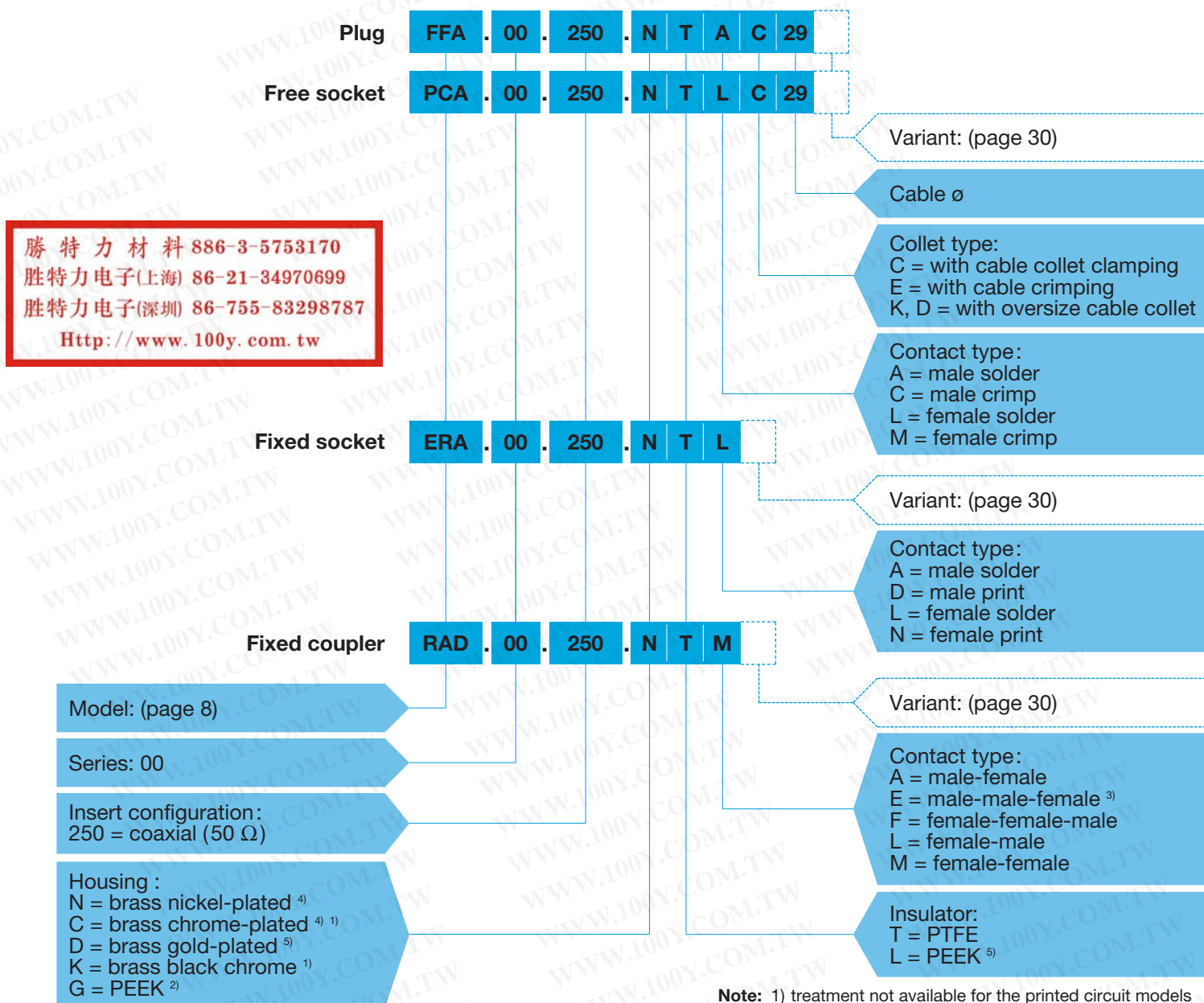

Note: 1) treatment not available for the printed circuit models
 2) available for the FFA and ERN model only
 3) used only for models: FTA, FTL and FTY.
 4) standard
 5) non-standard, on request only

Part Number Example

FFA.00.250.NTAC29 = straight plug with cable collet, series 00, coaxial type (50 Ω), outer shell in nickel-plated brass, PTFE insulator, male solder contact, C type collet of 2.9 mm diameter.

Part Section Showing Internal Components

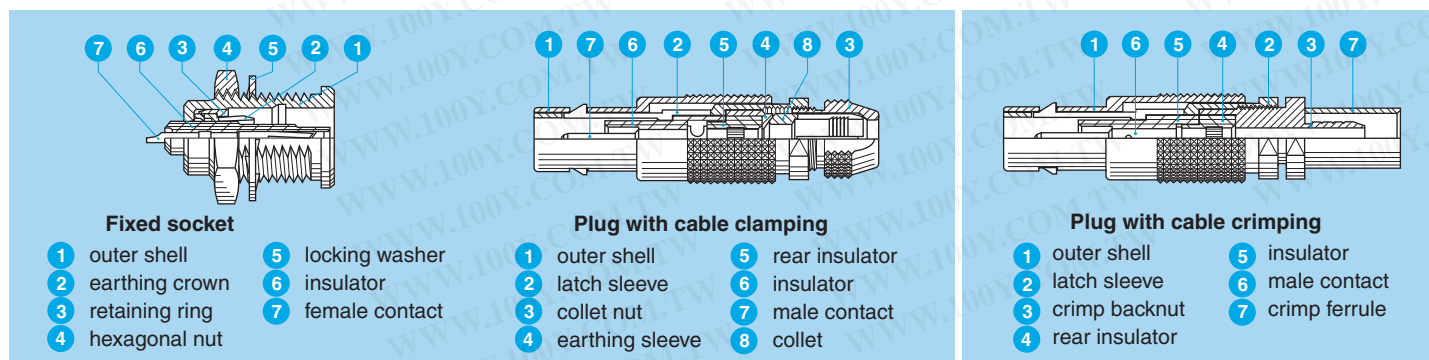

Metal housing models

Technical Characteristics

Mechanical and climatical

Characteristics	Value	Standard	Test
Contact retention force	> 18 N	IEC 60512-8	15a
Cable pull off force ¹⁾	> 100 N	IEC 60512-9	17c
Connector pull off force	> 90 N	IEC 60512-8	15f
Endurance	> 5000 cycles	IEC 60512-5	9a
Operating temperature	- 55°C + 260°C		

Note: ¹⁾ depending on cable design

Voltage Standing Wave Ratio

The VSWR (Voltage Standing Wave Ratio) is the value representing the power reflected in a connection. The VSWR varies with frequency, in most cases, the working frequency range is where VSWR is ≤ 1.25 .

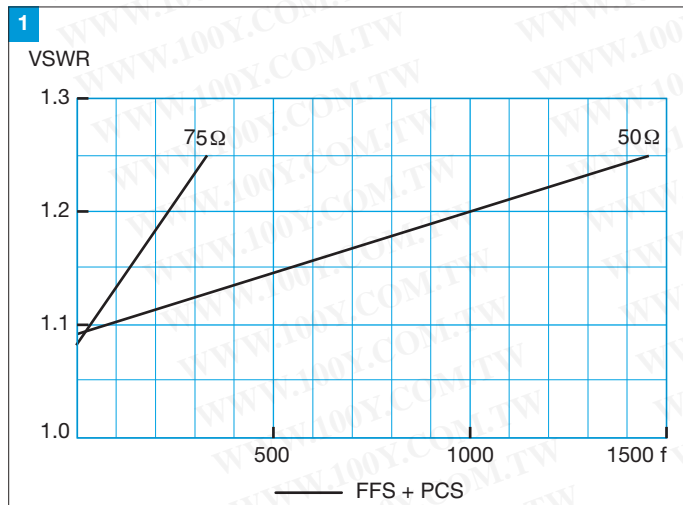

Note: value for connectors with PTFE insulator. VSWR measured 50 Ω with a RG-174 A/U cable and 75 Ω with a RG-179 B/U cable. Measured according to IEC-60169-1-1.

Electrical

Characteristics	Value	Standard	Test
Impedance	50 Ω	–	
Operating voltage (50 Hz)	0.7 kV rms	–	
Test voltage (50 Hz)	2.1 kV rms	IEC 60512-2	4a
Rated current	4 A	IEC 60512-3	5a
Contact resistance	< 6 m Ω	IEC 60512-2	2a
Shell electrical continuity	< 3.5 m Ω	IEC 60512-2	2f
Insulating resistance	> 10 ¹² Ω	IEC 60512-2	3a
VSWR	see chart N°1 below		
Shielding efficiency	see chart N°2 below		

Shielding efficiency (EMC properties) in dB (transfer impedance in dB Ω m)

The shielding efficiency is the ratio between the electromagnetic field inside the connector and a power source at the outside of the connector (or vice versa).

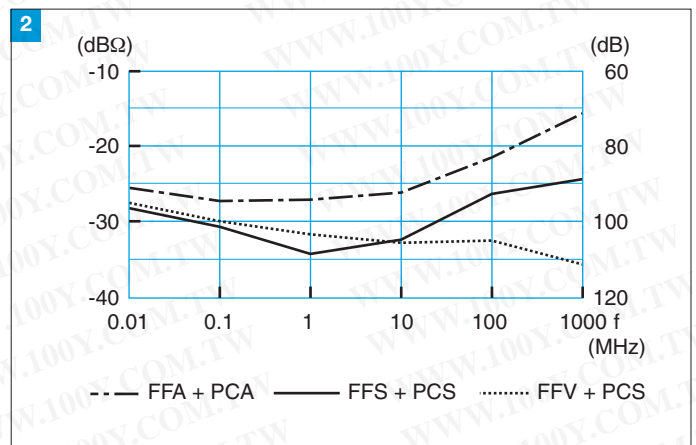

Note: measured according to IEC-60169-1-3 standard.

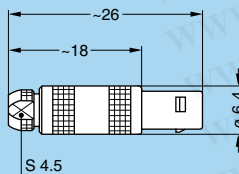

FFA Straight plug with cable collet

Part number	Cable group	Cond. \varnothing max.	Dielectric \varnothing max.	Sheath \varnothing	
				min.	max.
FFA.00.250.NTAC15	9	0.55	1.45	1.1	1.4
FFA.00.250.NTAC17	–	0.55	1.45	1.3	1.6
FFA.00.250.NTAC22	1	0.55	1.95	1.7	2.1
FFA.00.250.NTAC27	4	0.55	1.95	2.2	2.6
FFA.00.250.NTAC29	2-3	0.55	1.95	2.4	2.8
FFA.00.250.NTAC31	8	0.55	1.95	2.6	3.0

M1 Cable assembly, solder contact (page 39)



FFA Straight plug with oversize cable collet

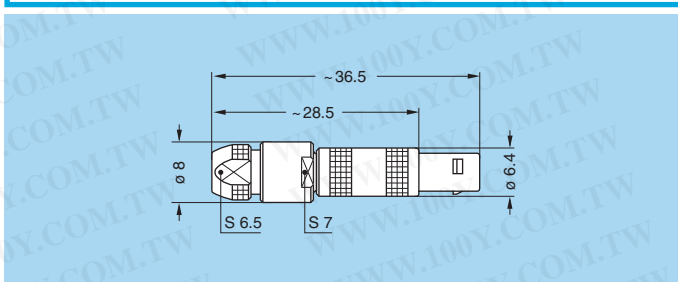

Part number	Cable group	Cond. Ø max	Dielectric Ø maxi	Sheath Ø	
				mini	maxi
FFA.00.250.NTAK37	8	0.55	1.95	3.0	3.6
FFA.00.250.NTAK42	-	0.55	1.95	3.3	4.1

M1 Cable assembly, solder contact (page 39)

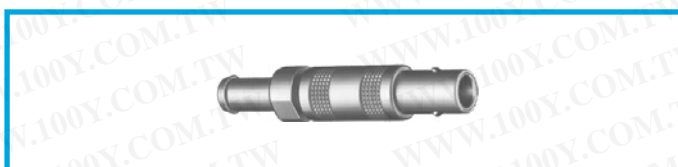

FFA Straight plug with cable collet and nut for fitting a bend relief

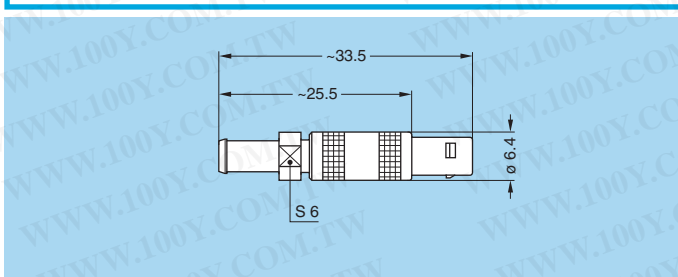

Part number	Cable group	Cond. Ø max	Dielectric Ø maxi	Sheath Ø	
				mini	maxi
FFA.00.250.NTAC15Z	9	0.55	1.45	1.1	1.4
FFA.00.250.NTAC17Z	-	0.55	1.45	1.3	1.6
FFA.00.250.NTAC22Z	1	0.55	1.95	1.7	2.1
FFA.00.250.NTAC27Z	4	0.55	1.95	2.2	2.6
FFA.00.250.NTAC29Z	2-3	0.55	1.95	2.4	2.8
FFA.00.250.NTAC31Z	8	0.55	1.95	2.6	3.0

M1 Cable assembly, solder contact (page 39)

Note: the bend relief must be ordered separately (see page 30).

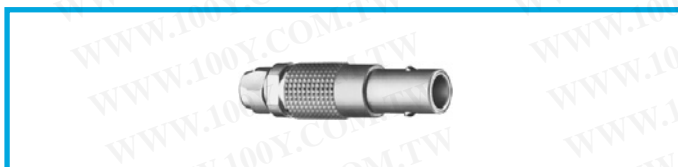

FFC Straight plug with flats on latch sleeve and cable collet

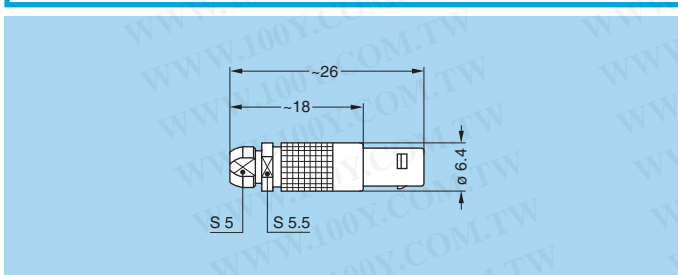

Part number	Cable group	Cond. Ø max	Dielectric Ø maxi	Sheath Ø	
				mini	maxi
FFC.00.250.CTAC22	1	0.60	1.55	1.7	2.1
FFC.00.250.CTAC27	4	0.60	1.95	2.2	2.6
FFC.00.250.CTAC29	2-3	0.60	1.95	2.4	2.8
FFC.00.250.CTAC31	8	0.60	1.95	2.6	3.0

M3 Cable assembly, solder contact (page 39)

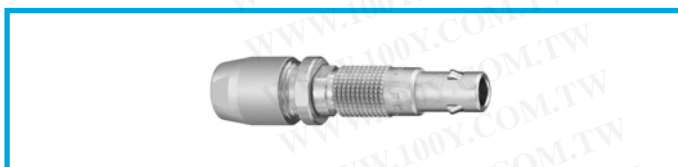

FFC Straight plug with flats on latch sleeve and oversize cable collet

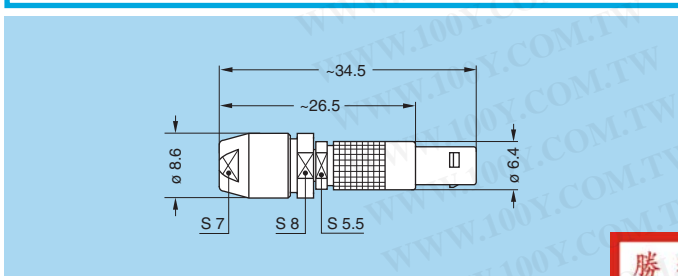

Part number	Cable group	Cond. Ø max	Dielectric Ø maxi	Sheath Ø	
				mini	maxi
FFC.00.250.CTAD42	5	1.05	3.05	3.1	4.0
FFC.00.250.CTAD52	6-7	1.05	3.05	4.1	5.0
FFC.00.250.CTAD56	-	1.05	3.05	5.1	5.5

M3 Cable assembly, solder contact (page 39)

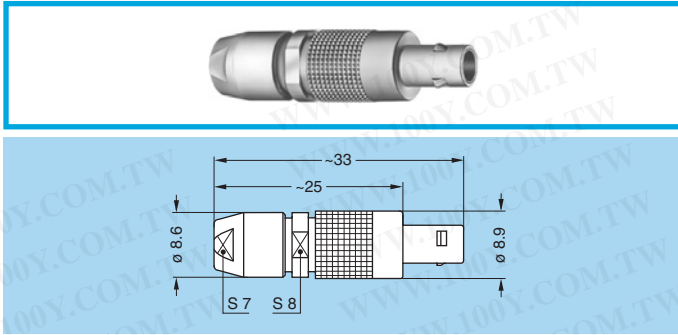

FFY Straight plug, large shell with cable collet

Part number	Cable group	Cond. Ø max	Dielectric Ø maxi	Sheath Ø	
				mini	maxi
FFY.00.250.NTAC40	5	1.05	3.05	3.2	3.8
FFY.00.250.NTAC47	-	1.05	3.05	3.9	4.5
FFY.00.250.NTAC52	6-7	1.05	3.05	4.6	5.0

M2 Cable assembly, solder contact (page 39)

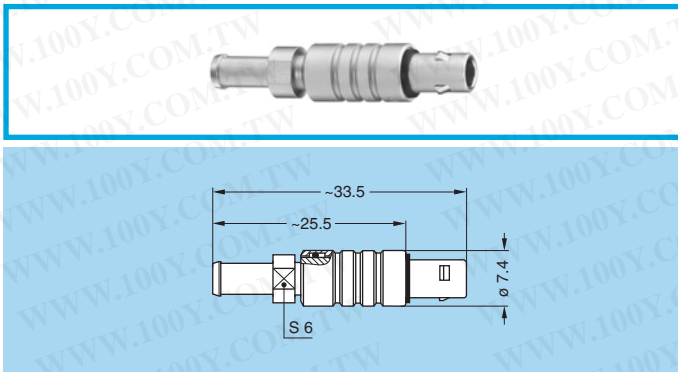

FFE Straight plug with front sealing ring, cable collet and nut for fitting a bend relief (IP 54 protection index when mated)

Part number	Cable group	Cond. Ø max	Dielectric Ø maxi	Sheath Ø	
				mini	maxi
FFE.00.250.NTAC22Z	1	0.55	1.95	1.7	2.1
FFE.00.250.NTAC27Z	4	0.55	1.95	2.2	2.6
FFE.00.250.NTAC29Z	2-3	0.55	1.95	2.4	2.8
FFE.00.250.NTAC31Z	8	0.55	1.95	2.6	3.0

M1 Cable assembly, solder contact (page 39)

Note: the bend relief must be ordered separately (see page 30).

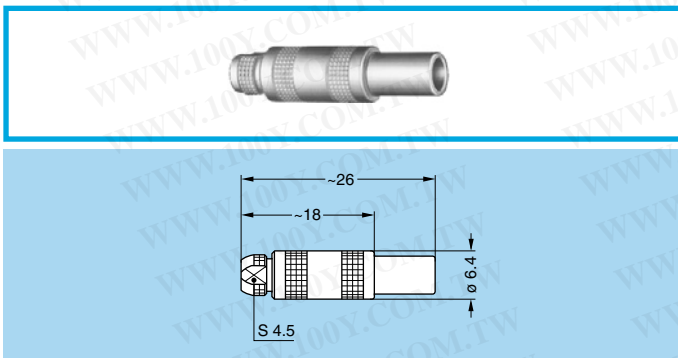

FFF Straight plug, non-latching, with cable collet

Part number	Cable group	Cond. Ø max	Dielectric Ø maxi	Sheath Ø	
				mini	maxi
FFF.00.250.NTAC22	1	0.55	1.95	1.7	2.1
FFF.00.250.NTAC27	4	0.55	1.95	2.2	2.6
FFF.00.250.NTAC29	2-3	0.55	1.95	2.4	2.8
FFF.00.250.NTAC31	8	0.55	1.95	2.6	3.0

M1 Cable assembly, solder contact (page 39)



FFS Straight plug for cable crimping

Part number	Dim		Cable group	Cond. Ø maxi	Dielec. Ø maxi	Sheath Ø maxi
	L	M				
FFS.00.250.CTAE24	31	23	1	0.4	0.95	2.35
FFS.00.250.CTAE31	31	23	3-4	0.55	1.65	3.0
FFS.00.250.CTAE52	34	26	6	0.97	3.05	5.2

M5 Cable assembly, solder contact (page 41)

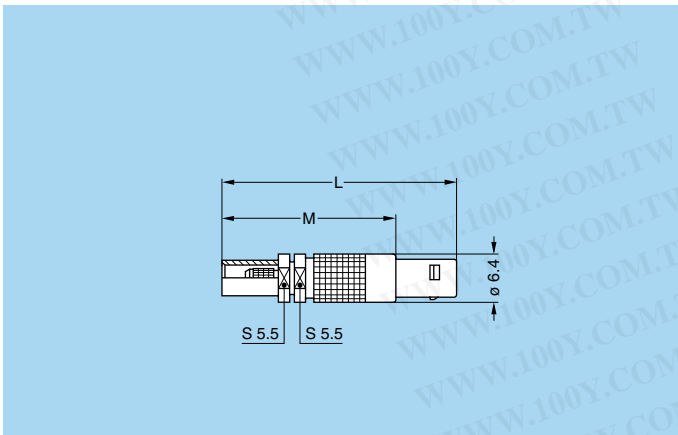

Part number	Dim		Cable group	Cond. Ø		Dielec. Ø maxi	Sheath Ø maxi
	L	M		mini	maxi		
FFS.00.250.CTCE24	31	23	1	0.28	0.4	0.95	2.35
FFS.00.250.CTCE25	31	23	1	0.28	0.4	1.15	2.35
FFS.00.250.CTCE30	31	23	2	0.28	0.4	1.65	3.0
FFS.00.250.CTCE31	31	23	3-4	0.46	0.55	1.65	3.0
FFS.00.250.CTCE35	31	23	8	0.46	0.55	1.65	3.35
FFS.00.250.CTCE44	31	23	5	0.28	0.4	2.65	4.35
FFS.00.250.CTCE52	34	26	6	0.90	0.97	3.05	5.2
FFS.00.250.CTCE56	34	26	7	0.90	0.97	3.05	5.45

M4 Cable assembly, crimp contact (page 40)

勝特力材料 886-3-5753170
 勝特力电子(上海) 86-21-34970699
 勝特力电子(深圳) 86-755-83298787
[Http://www.100y.com.tw](http://www.100y.com.tw)



FFV Straight plug for cable crimping with improved screen efficiency ¹⁾

Part number	Dim		Cable group	Cond. Ø maxi	Dielec. Ø maxi	Sheath Ø maxi
	L	M				
FFV.00.250.NTAE24	31	23	1	0.4	0.95	2.35
FFV.00.250.NTAE31	31	23	3-4	0.55	1.65	3.0
FFV.00.250.NTAE52	34	26	6	0.97	3.05	5.2

M5 Cable assembly, solder contact (page 41)

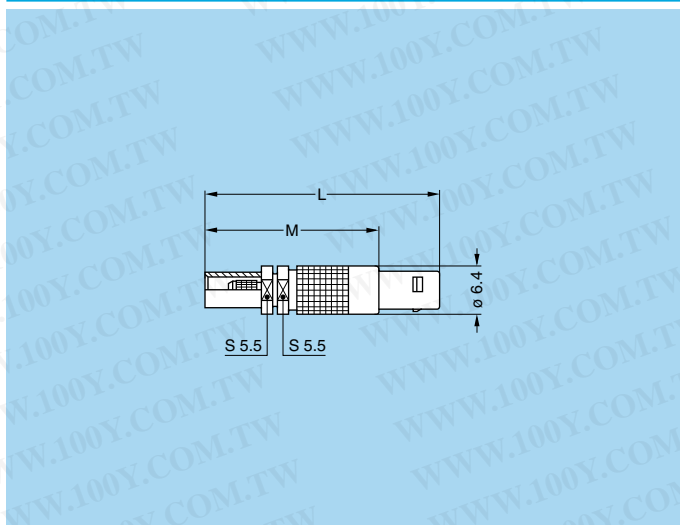

Part number	Dim		Cable group	Cond. Ø		Dielec. Ø maxi	Sheath Ø maxi
	L	M		mini	maxi		
FFV.00.250.NTCE24	31	23	1	0.28	0.4	0.95	2.35
FFV.00.250.NTCE30	31	23	2	0.28	0.4	1.65	3.0
FFV.00.250.NTCE31	31	23	3-4	0.46	0.55	1.65	3.0
FFV.00.250.NTCE35	31	23	8	0.46	0.55	1.65	3.35
FFV.00.250.NTCE44	31	23	5	0.28	0.4	2.65	4.35
FFV.00.250.NTCE52	34	26	6	0.90	0.97	3.05	5.2
FFV.00.250.NTCE56	34	26	7	0.90	0.97	3.05	5.45

M4 Cable assembly, crimp contact (page 40)

Note: ¹⁾ Screen efficiency >100dB at 1 GHz, see page 8.

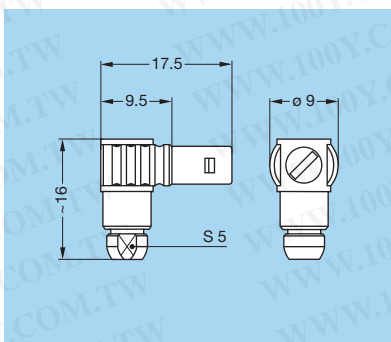

FLA Elbow plug (90°) with cable collet

Part number	Cable group	Cond. Ø max	Dielectric Ø maxi	Sheath Ø	
				mini	maxi
FLA.00.250.CTAC22	1	0.35	1.55	1.7	2.1
FLA.00.250.CTAC27	4	0.35	1.75	2.2	2.6
FLA.00.250.CTAC29	2-3	0.35	1.75	2.4	2.8
FLA.00.250.CTAC31	8	0.35	1.75	2.6	3.0

M6 Cable assembly, solder contact (page 42)

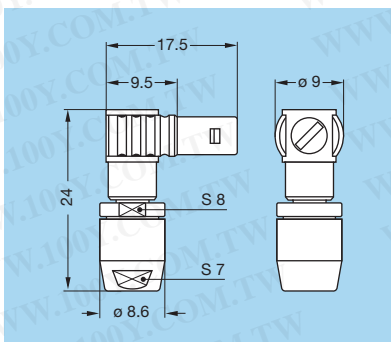

FLA Elbow plug (90°) with oversized cable collet

Part number	Cable group	Cond. Ø max	Dielectric Ø maxi	Sheath Ø	
				mini	maxi
FLA.00.250.CTAD42	8	0.97	1.75	3.1	4.0
FLA.00.250.NTAD52	6	0.97	1.75	4.1	5.0
FLA.00.250.NTAD56	7	0.97	1.75	5.1	5.5

M6 Cable assembly, solder contact (page 42)

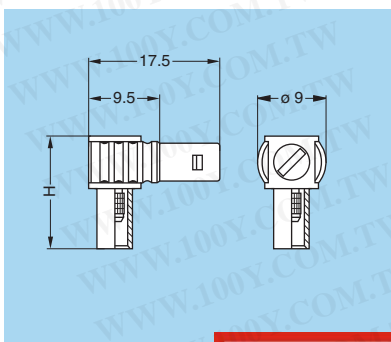

FLS Elbow plug (90°) for cable crimping

Part number	H (mm)	Cable group	Cond. Ø maxi	Dielectric Ø maxi	Sheath Ø maxi
FLS.00.250.NTAE31	15	3-4	0.35	1.65	3.0
FLS.00.250.NTAE35	15	8	0.35	1.65	3.35
FLS.00.250.NTAE52	18	6	0.97	3.05	5.2
FLS.00.250.NTAE56	18	7	0.97	3.05	5.45

M7 Cable assembly, solder contact (page 42)

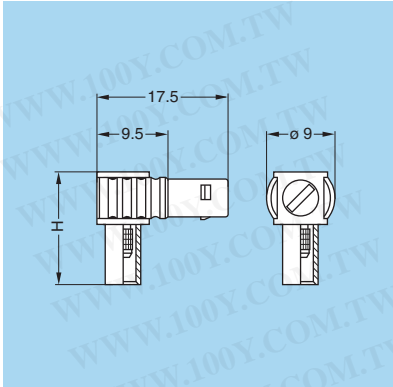

FLV Elbow plug (90°) for cable crimping with improved screen efficiency *

Part number	H (mm)	Cable group	Cond. Ø maxi	Dielectric Ø maxi	Sheath Ø maxi
FLV.00.250.NTAE31	15	3-4	0.35	1.65	3.0
FLV.00.250.NTAE35	15	8	0.35	1.65	3.35
FLV.00.250.NTAE52	18	6	0.97	3.05	5.2
FLV.00.250.NTAE56	18	7	0.97	3.05	5.45

M7 Cable assembly, solder contact (page 42)

* Screen efficiency >100dB at 1 GHz, see page 8.

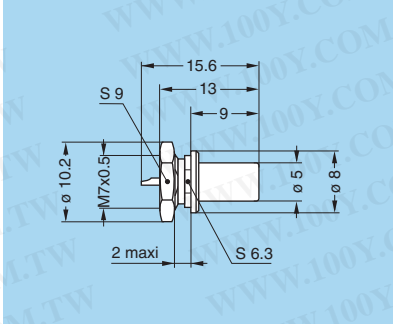

FAA Straight plug, non-latching, nut fixing

Part number	Weight (g)
FAA.00.250.NTA	2.5

P5 Panel cut-out (page 38)

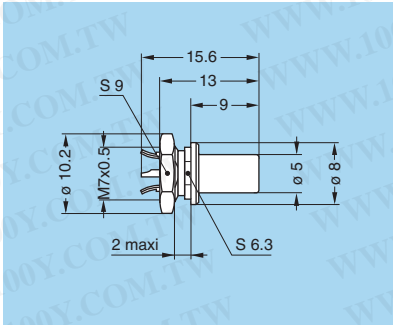

FAN Straight plug, non-latching, nut fixing with earthing tags

Part number	Weight (g)
FAN.00.250.CLA	2.5

P5 Panel cut-out (page 38)

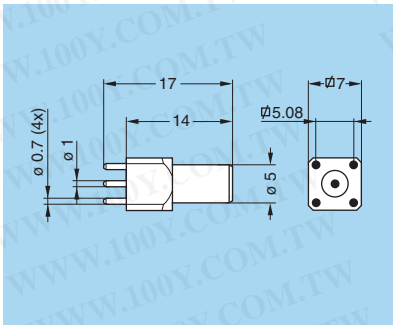
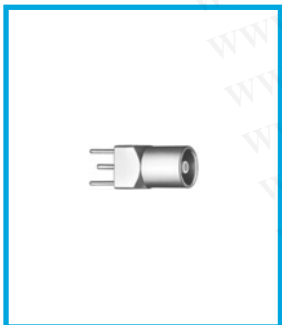

FPA Straight plug, non-latching, for printed circuit

Part number	Weight (g)
FPA.00.250.NTD	2.5

P11 PCB drilling pattern (page 38)

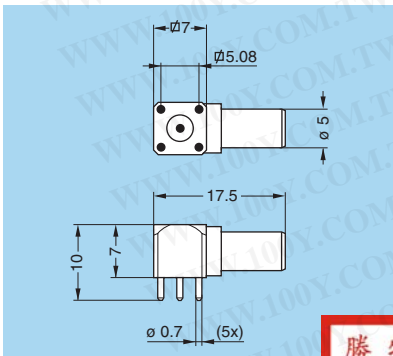
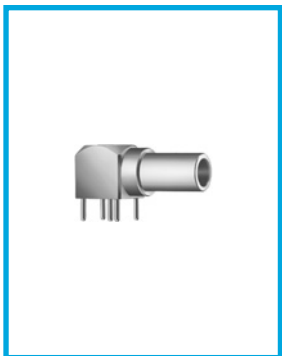

FPL Elbow plug (90°), non-latching for printed circuit

Part number	Weight (g)
FPL.00.250.NTD	2.5

P10 PCB drilling pattern (page 38)

勝特力材料 886-3-5753170
 勝特力电子(上海) 86-21-34970699
 勝特力电子(深圳) 86-755-83298787
[Http://www.100y.com.tw](http://www.100y.com.tw)

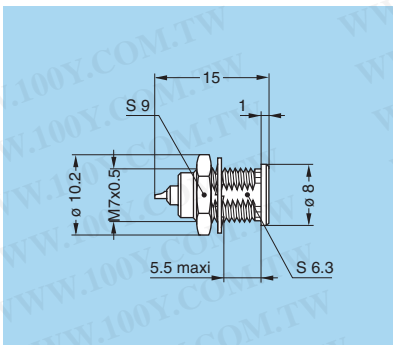

ERA Fixed socket, nut fixing

Part number	Weight (g)
ERA.00.250.NTL	2.5

P5 Panel cut-out (page 38)

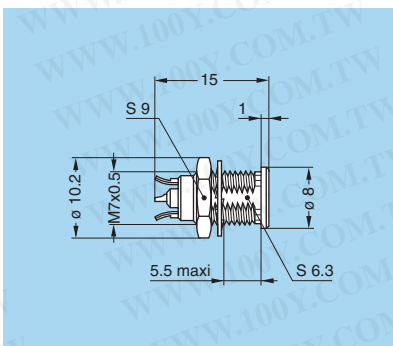

ERN Fixed socket, nut fixing, with earthing tags

Part number	Weight (g)
ERN.00.250.NTL	2.5

P5 Panel cut-out (page 38)

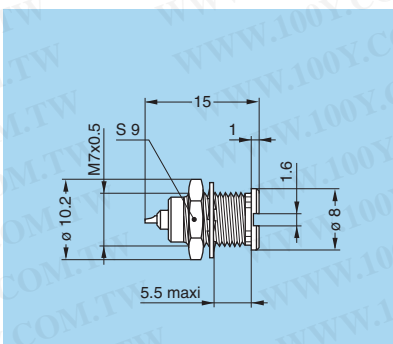

ERC Fixed socket, with thread, with slots in flange

Part number	Weight (g)
ERC.00.250.NTL	2.6

P1 Panel cut-out (page 38)

P3 Panel cut-out for use without hexagonal nut (page 38)

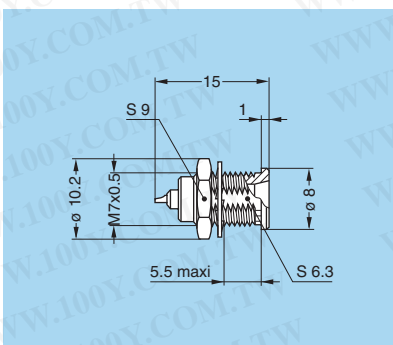

ERE Fixed socket, nut fixing, with conical lead-in

Part number	Weight (g)
ERE.00.250.NTL	2.8

P5 Panel cut-out (page 38)

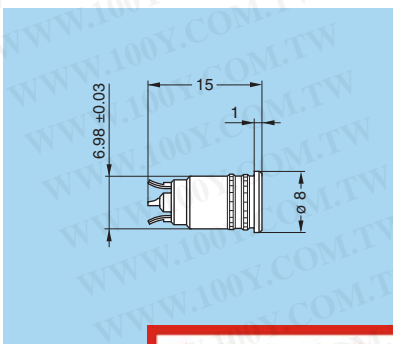

ERT Straight socket without thread, force or adhesive fit, with earthing tags

Part number	Weight (g)
ERT.00.250.NTL	2.1

P4 Panel cut-out (page 38)

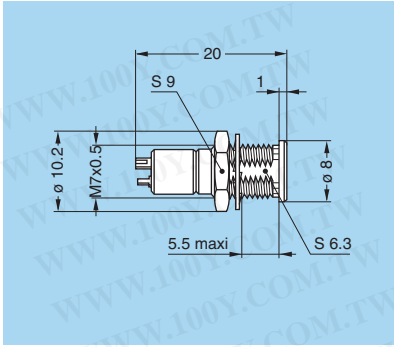
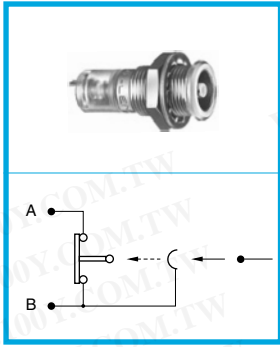

ERM Fixed socket, nut fixing, with microswitch

Part number	Weight (g)
ERM.00.250.NTL	3.0

P5 Panel cut-out (page 38)

Technical characteristics on request

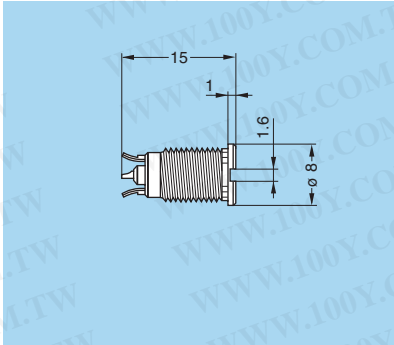

ERX Fixed socket, with thread, with slots in flange, with earthing tags

Part number	Weight (g)
ERX.00.250.NTL	2.0

P3 Panel cut-out (page 38)

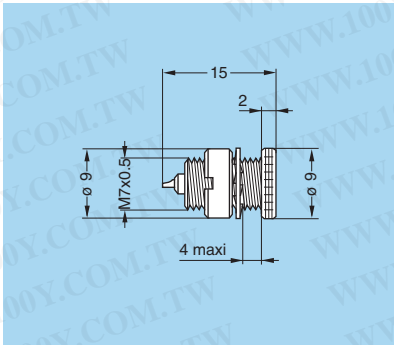

ECP Fixed socket with two nuts

Part number	Weight (g)
ECP.00.250.NTL	3.3

P1 Panel cut-out (page 38)

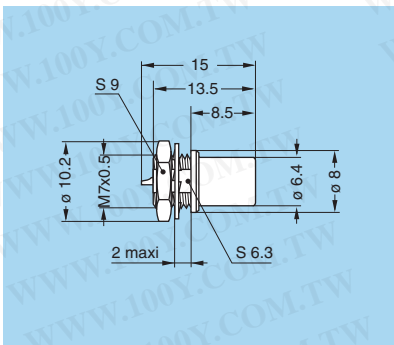

EHP Fixed socket, nut fixing, protruding shell

Part number	Weight (g)
EHP.00.250.NTL	2.8

P5 Panel cut-out (page 38)

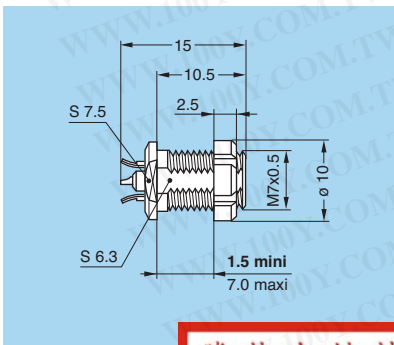

ELF Fixed socket, with slotted nut, long threaded shell, with earthing tags (back panel mounting)

Part number	Weight (g)
ELF.00.250.NTL	3.1

P5 Panel cut-out (page 38)

勝特力材料 886-3-5753170
 勝特力电子(上海) 86-21-34970699
 勝特力电子(深圳) 86-755-83298787
[Http://www.100y.com.tw](http://www.100y.com.tw)

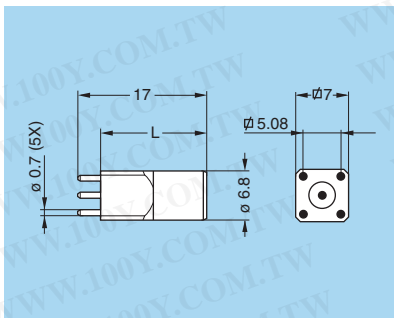

EPA-EPB Straight socket for printed circuit

Part number	L (mm)	Weight (g)
EPA.00.250.NTN	14	3.4
EPB.00.250.NTN	12	3.3

P10 PCB drilling pattern (page 38)

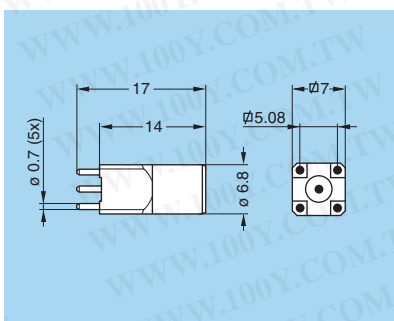

EPC Straight socket for printed circuit with clearance under the body

Part number	Weight (g)
EPC.00.250.NTN	3.3

P10 PCB drilling pattern (page 38)

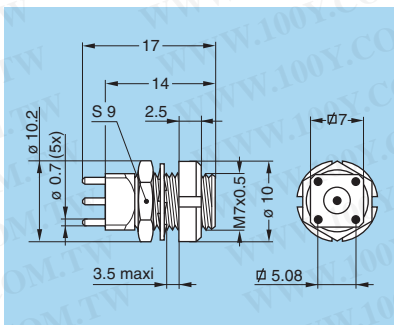

EPE Fixed socket with two nuts, for printed circuit

Part number	Weight (g)
EPE.00.250.NTN	4.3

P1 Panel cut-out (page 38)

P12 PCB drilling pattern (page 38)

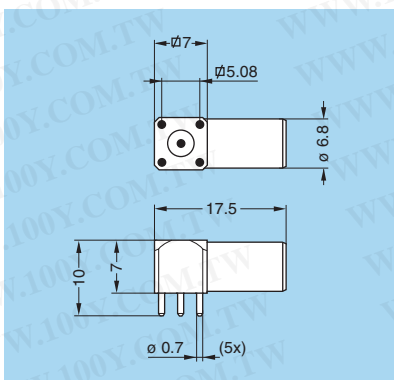

EPL Elbow socket (90°) for printed circuit

Part number	H (mm)	Weight (g)
EPL.00.250.NTN	10	4.3

P10 PCB drilling pattern (page 38)

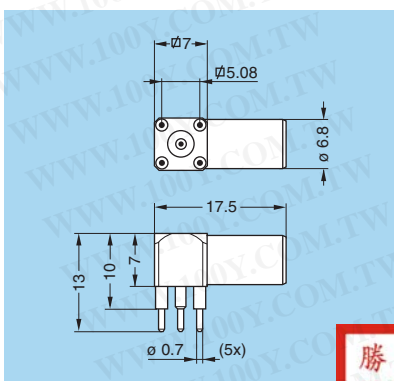

EPM Elbow socket (90°) for printed circuit, elevated solder tail

Part number	H (mm)	Weight (g)
EPM.00.250.NTN	13	4.6

P10 PCB drilling pattern (page 38)

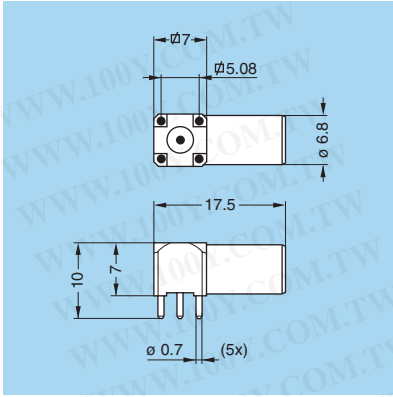

EPK Elbow socket (90°) for printed circuit with clearance under the body

Part number	Weight (g)
EPK.00.250.NTN	4.2

P10 PCB drilling pattern (page 38)

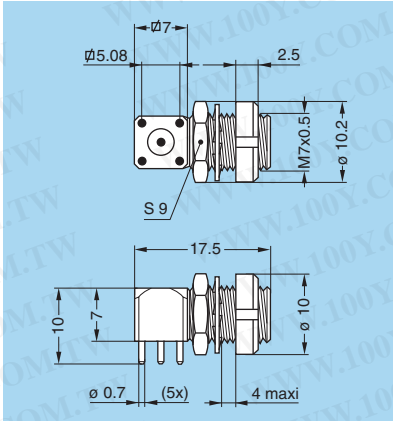

EPS Elbow socket (90°) with two nuts, for printed circuit

Part number	Weight (g)
EPS.00.250.NTN	5.4

P1 Panel cut-out (page 38)

P12 PCB drilling pattern (page 38)

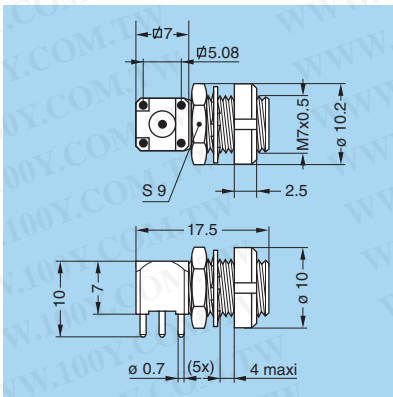

EPR Elbow socket (90°) with two nuts for printed circuit, with clearance under the body (back panel mounting)

Part number	Weight (g)
EPR.00.250.NTN	5.4

P1 Panel cut-out (page 38)

P12 PCB drilling pattern (page 38)

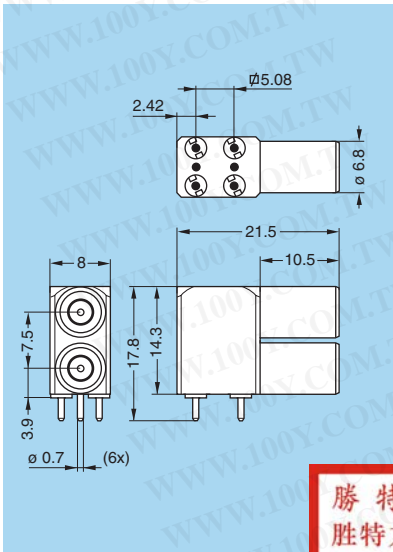
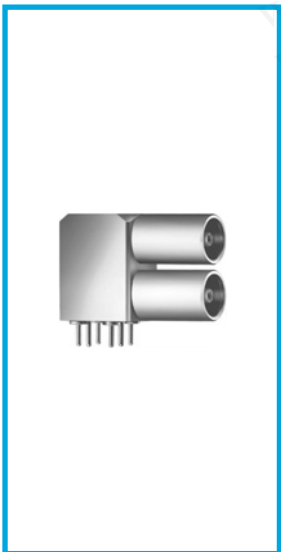

EPY Elbow socket (90°) for printed circuit, with two vertical sockets

Part number	Weight (g)
EPY.00.250.NTN	12.8

P13 PCB drilling pattern (page 38)

勝特力材料 886-3-5753170
 勝特力电子(上海) 86-21-34970699
 勝特力电子(深圳) 86-755-83298787

[Http://www.100y.com.tw](http://www.100y.com.tw)

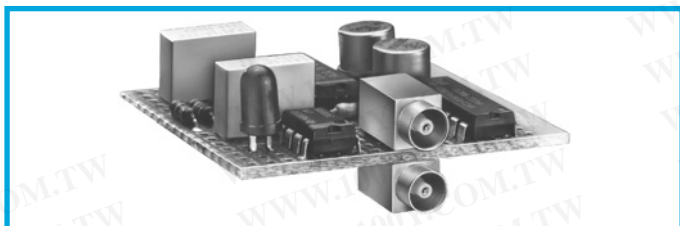

EPN Straight socket for press mounting in pair on printed circuit

Part number	Weight (g)
EPN.00.250.NTN	3.6

P9 PCB drilling pattern (page 38)

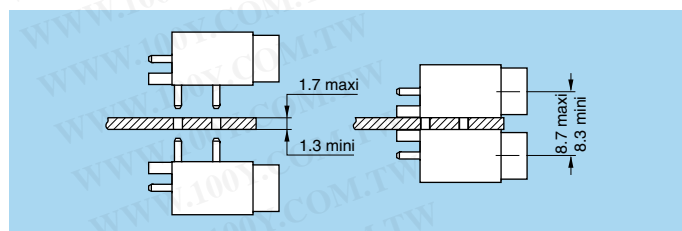
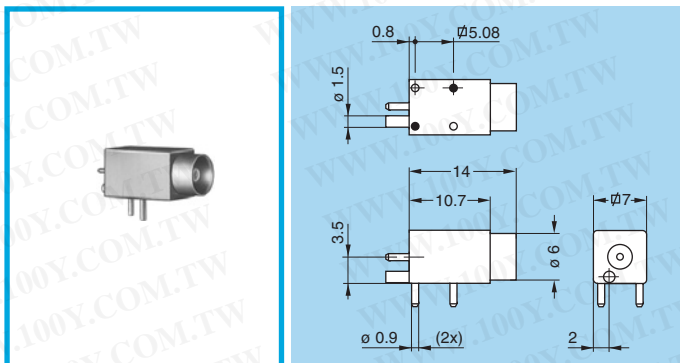

PCA Free socket with cable collet

Part number	Cable group	Cond. Ø max	Dielectric Ø maxi	Sheath Ø	
				mini	maxi
PCA.00.250.NTLC15	9	0.55	1.45	1.1	1.4
PCA.00.250.NTLC22	1	0.55	1.95	1.7	2.1
PCA.00.250.NTLC27	4	0.55	1.95	2.2	2.6
PCA.00.250.NTLC29	2-3	0.55	1.95	2.4	2.8
PCA.00.250.NTLC31	8	0.55	1.95	2.6	3.0

M1 Cable assembly (page 39)

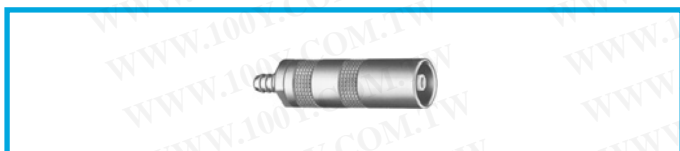
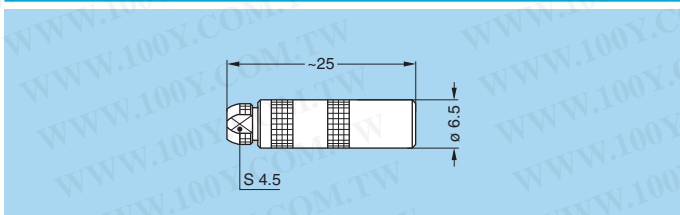

PCS Free socket for cable crimping

Part number	Dim L	Cable group	Cond. Ø		Dielec. Ø maxi	Sheath Ø maxi
			mini	maxi		
PCS.00.250.NTME24	30	1	0.28	0.4	0.95	2.35
PCS.00.250.NTME30	30	2	0.28	0.4	1.65	3.0
PCS.00.250.NTME31	30	3-4	0.46	0.55	1.65	3.0
PCS.00.250.NTME44	30	5	0.28	0.4	2.65	4.35
PCS.00.250.NTME52	33	6	0.90	0.97	3.05	5.2

M4 Cable assembly, crimp contact (page 40)

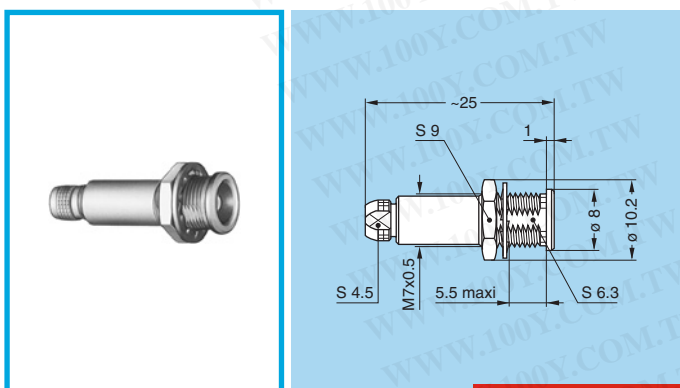
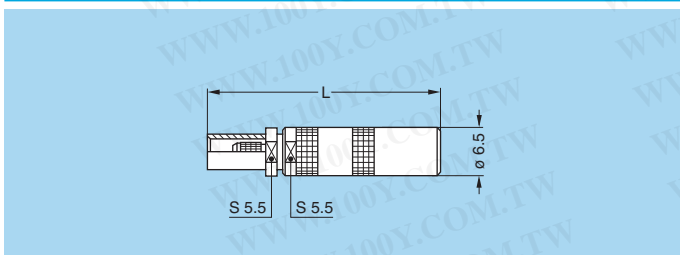

PSA Fixed socket, nut fixing, with cable collet

Part number	Cable group	Cond. Ø max	Dielectric Ø maxi	Sheath Ø	
				mini	maxi
PSA.00.250.NTLC22	1	0.55	1.95	1.7	2.1
PSA.00.250.NTLC27	4	0.55	1.95	2.2	2.6
PSA.00.250.NTLC29	2-3	0.55	1.95	2.4	2.8
PSA.00.250.NTLC31	8	0.55	1.95	2.6	3.0

M1 Cable assembly (page 39)

P5 Panel cut-out (page 38)

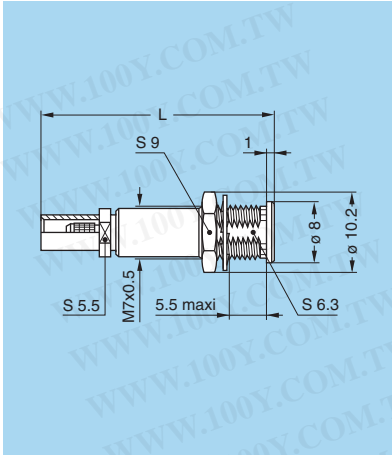

PSS Fixed socket, nut fixing, for cable crimping

Part number	Dim L	Cable group	Cond. Ø		Dielec. Ø maxi	Sheath Ø maxi
			mini	maxi		
PSS.00.250.NTME24	30	1	0.28	0.4	0.95	2.35
PSS.00.250.NTME30	30	2	0.28	0.4	1.65	3.0
PSS.00.250.NTME31	30	3-4	0.46	0.55	1.65	3.0
PSS.00.250.NTME35	30	8	0.46	0.55	1.65	3.35
PSS.00.250.NTME52	33	6	0.90	0.97	3.05	5.2

M4 Cable assembly, crimp contact (page 40)

P5 Panel cut-out (page 38)

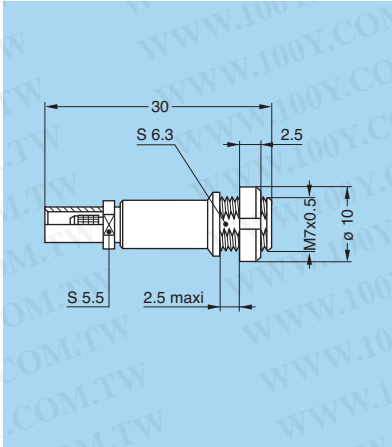

PES Fixed socket, nut fixing, for cable crimping (back panel mounting)

Part number	Cable group	Cond. Ø		Dielectric Ø maxi	Sheath Ø maxi
		mini	maxi		
PES.00.250.NTME24	1	0.28	0.4	0.95	2.35
PES.00.250.NTME30	2	0.28	0.4	1.65	3.0
PES.00.250.NTME31	3-4	0.46	0.55	1.65	3.0
PES.00.250.NTME35	8	0.46	0.55	1.65	3.35

M4 Cable assembly, crimp contact (page 40)

P5 Panel cut-out (page 38)

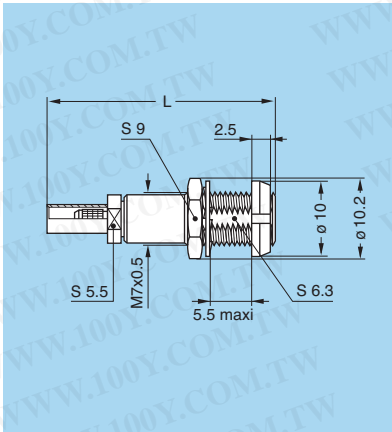

PFS Fixed socket, with two nuts, for cable crimping (back panel mounting)

Part number	Dim L	Cable group	Cond. Ø		Dielec. Ø maxi	Sheath Ø maxi
			mini	maxi		
PFS.00.250.NTME24	30	1	0.28	0.4	0.95	2.35
PFS.00.250.NTME31	30	3-4	0.46	0.55	1.65	3.0
PFS.00.250.NTME52	33	6	0.90	0.95	3.05	5.2

P5 Panel cut-out (page 38)

Cable assembly, please contact customer services

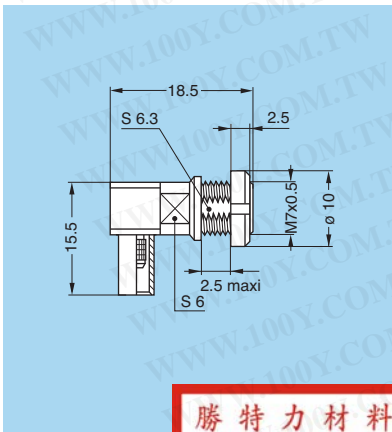

PLK Fixed elbow socket (90°), for cable crimping (back panel mounting)

Part number	Cable group	Cond. Ø		Dielectric Ø maxi	Sheath Ø maxi
		mini	maxi		
PLK.00.250.NTLE31	3-4	0.46	0.55	1.65	3.0
PLK.00.250.NTLE35	8	0.46	0.55	1.65	3.35

P5 Panel cut-out (page 38)

Cable assembly, please contact customer services

勝特力材料 886-3-5753170
 勝特力电子(上海) 86-21-34970699
 勝特力电子(深圳) 86-755-83298787
[Http://www.100y.com.tw](http://www.100y.com.tw)

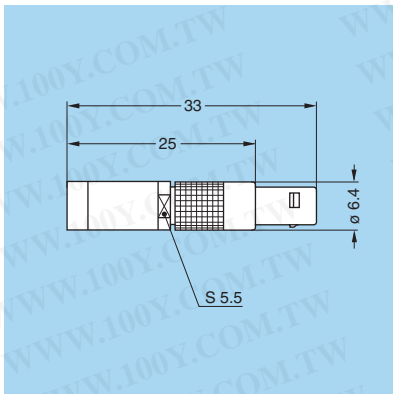

FRT Straight plug with resistor

Part number	Resistor	Weight (g)	Note
FRT.00.250.NTA00	shorted	4.4	●
FRT.00.250.NTA50	50 Ω 0.6W	4.4	●
FRT.00.250.NTA100	100 Ω 0.4W	4.4	○

Note: ● Standard, first choice alternative
○ Non standard, on request only

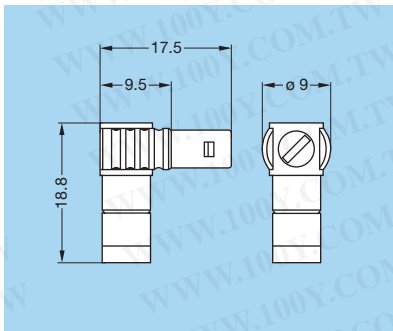

FLR Elbow plug (90°) with resistor

Part number	Resistor	Weight (g)
FLR.00.250.NTA50	50 Ω 0.6W	5.6

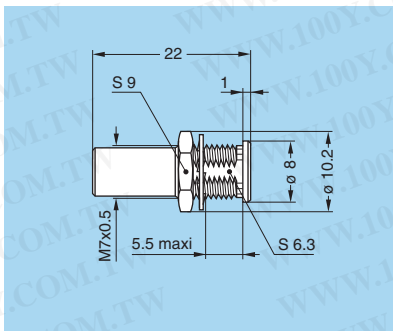

RAD Fixed coupler, nut fixing

Part number	Weight (g)
RAD.00.250.NTM	3.8

P5 Panel cut-out (page 38)

Note: the first contact type mentioned (page 7) is always the contact at the flange end.

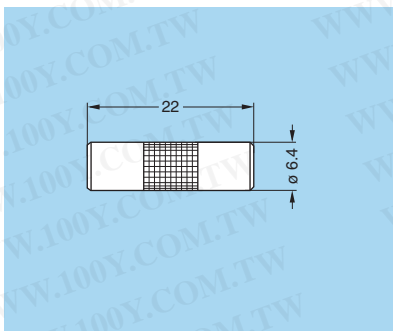

RMA Free coupler

Part number	Weight (g)
RMA.00.250.NTM	2.7

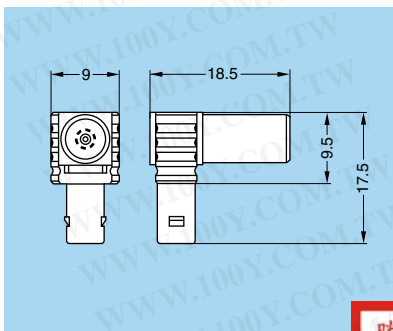

FTR Elbow plug (90°) with socket

Part number	Weight (g)
FTR.00.250.NTA	5.4

勝特力材料 886-3-5753170
 勝特力电子(上海) 86-21-34970699
 勝特力电子(深圳) 86-755-83298787
[Http://www.100y.com.tw](http://www.100y.com.tw)

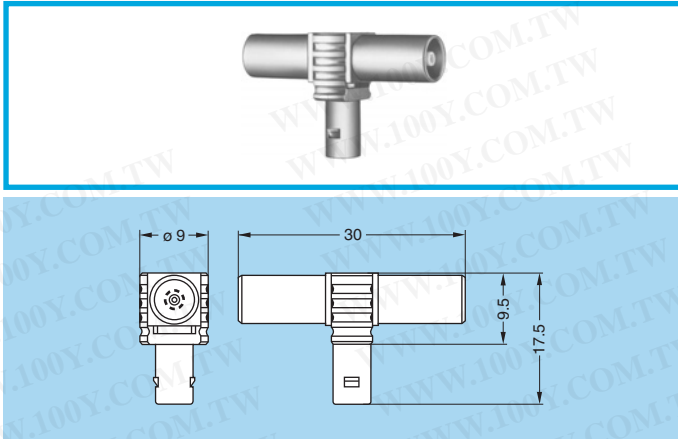

FTA T-plug with two sockets in line

Part number	Weight (g)
FTA.00.250.NTF	7.8

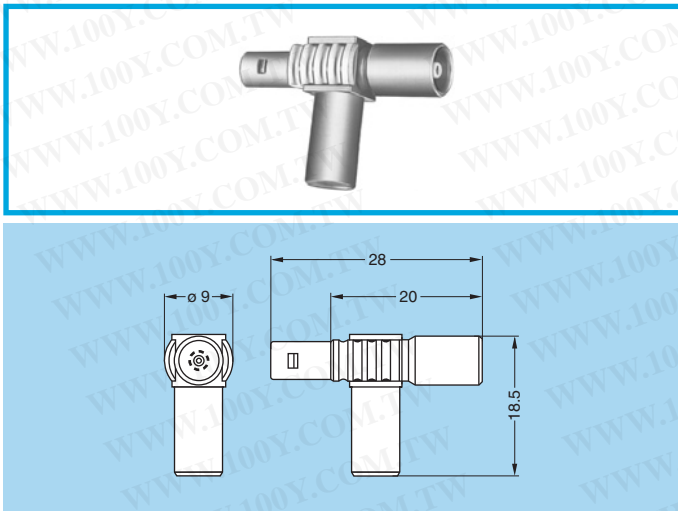

FTL T-plug with two sockets (90°)

Part number	Weight (g)
FTL.00.250.NTF	7.1

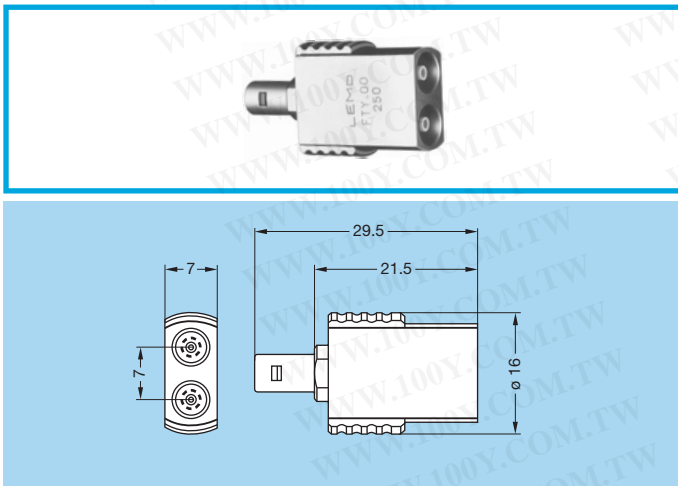

FTY Straight plug with two parallel sockets

Part number	Weight (g)
FTY.00.250.NTF	12.5

勝特力材料 886-3-5753170
 勝特力电子(上海) 86-21-34970699
 勝特力电子(深圳) 86-755-83298787
[Http://www.100y.com.tw](http://www.100y.com.tw)

Plastic housing models

This plastic housing provides the ideal solution when the isolation of the connector is critical (non metallic). The FFA and ERN models in PEEK allow weight saving and can provide ease of use in applications such as medical electronic instrumentation.

Technical Characteristics

Mechanical and climatical

Characteristics	Value	Standard	Test
Contact retention force	> 18 N	IEC 60512-8	15a
Cable pull off force	> 100 N	IEC 60512-9	17a
Connector pull off force	> 90 N		
Endurance	> 5000 cycles	IEC 60512-5	9a
Operating temperature	- 50°C + 250°C		

勝特力材料 886-3-5753170
勝特力电子(上海) 86-21-34970699
勝特力电子(深圳) 86-755-83298787
[Http://www.100y.com.tw](http://www.100y.com.tw)

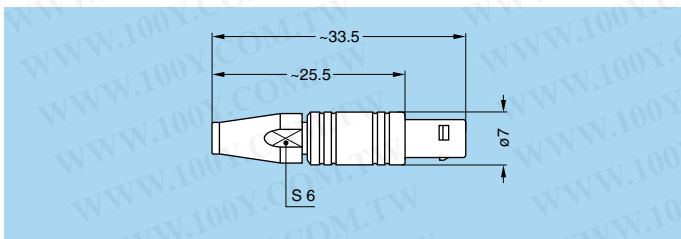

FFA Straight plug with cable collet, PEEK outer shell

Part number	Cable group	Cond. Ø max	Dielectric Ø maxi	Sheath Ø	
				mini	maxi
FFA.00.250.GTAC15	9	0.55	1.45	1.1	1.4
FFA.00.250.GTAC17	-	0.55	1.45	1.3	1.6
FFA.00.250.GTAC22	1	0.55	1.95	1.7	2.1
FFA.00.250.GTAC27	4	0.55	1.95	2.2	2.6
FFA.00.250.GTAC29	2-3	0.55	1.95	2.4	2.8
FFA.00.250.GTAC31	8	0.55	1.95	2.6	3.0

M1 Cable assembly (page 39)

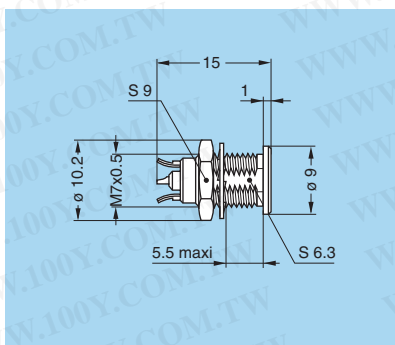

ERN Fixed socket, nut fixing, with earthing tags, PEEK outer shell

Part number	Weight (g)
ERN.00.250.GTL	1.4

P5 Panel cut-out (page 38)

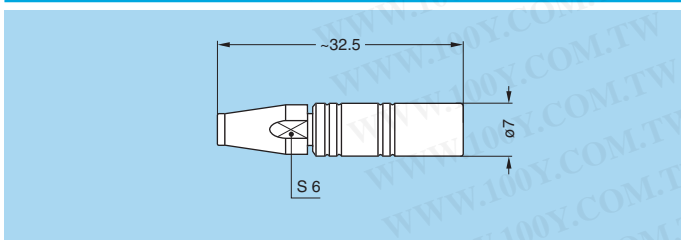

PCA Free socket with cable collet, PEEK outer shell

Part number	Cable group	Cond. Ø max	Dielectric Ø maxi	Sheath Ø	
				mini	maxi
PCA.00.250.GTLC15	9	0.55	1.45	1.1	1.4
PCA.00.250.GTLC17	-	0.55	1.45	1.3	1.6
PCA.00.250.GTLC22	1	0.55	1.95	1.7	2.1
PCA.00.250.GTLC27	4	0.55	1.95	2.2	2.6
PCA.00.250.GTLC29	2-3	0.55	1.95	2.4	2.8
PCA.00.250.GTLC31	8	0.55	1.95	2.6	3.0

M1 Cable assembly (page 39)

Watertight or vacuumtight models

A range of sealed sockets and couplers allows the device on which they are fitted to reach a protection index of IP68 as per IEC 60529 (unmated). They are fully compatible with plugs of the same series and are widely used for portable radios, military, laboratory equipment, aviation, etc.

These models are identified by a letter «P» at the end of the reference for watertight model and by a «PV» for vacuumtight models. Epoxy resin or o-rings are used to seal these models.

Mechanical and climatical

Characteristics	Value	Standard
Endurance	> 5000 cycles	IEC 60512-5 test 9a
Humidity	up to 95% at 60° C	
Temperature range	- 20° C/+100° C	
Salt spray corrosion test	> 144h	IEC 60512-6 test 11f
Climatical category	20/80/21	IEC 60068-1
Leakage rate (He) ¹⁾	< 10 ⁻⁷ mbar.l.s ⁻¹	IEC 60512-7 test 14b
Maximum operating pressure ²⁾	60 bars	IEC 60512-7 test 14d

勝特力材料 886-3-5753170
 勝特力电子(上海) 86-21-34970699
 勝特力电子(深圳) 86-755-83298787
[Http://www.100y.com.tw](http://www.100y.com.tw)

Note:

- 1) only for vacuumtight models.
- 2) this value corresponds to the maximum allowed pressure difference for the assembled socket.

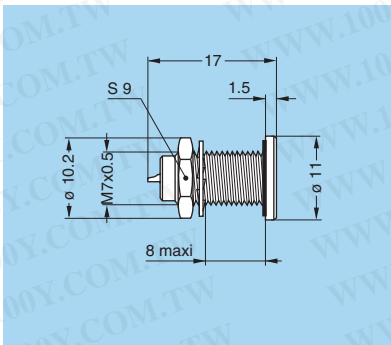

HGP Fixed socket, nut fixing, watertight or vacuumtight

Part number	Weight (g)
HGP.00.250.NTLP	4.2
HGP.00.250.NTLPV	4.2

P1 Panel cut-out (page 38)

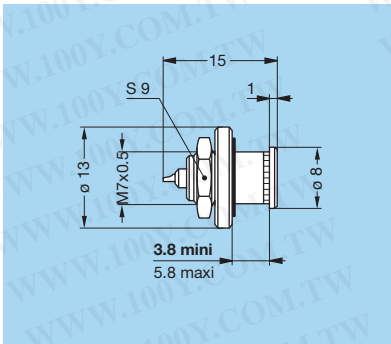

HGW Fixed socket, nut fixing, watertight with rear sealing ring

Part number	Weight (g)
HGW.00.250.NTLP	4.2

P1 Panel cut-out (page 38)

Note: Non standard, on request only

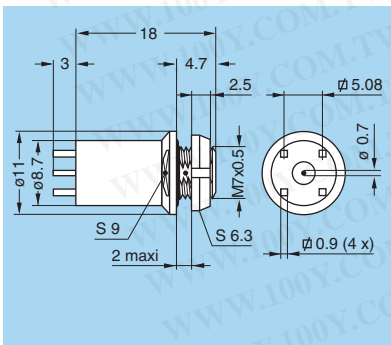

HEP Fixed socket, nut fixing, watertight for printed circuit (back panel mounting)

Part number	Weight (g)
HEP.00.250.NTNP	7.4

P5 Panel cut-out (page 38)

P15 PCB drilling pattern (page 38)

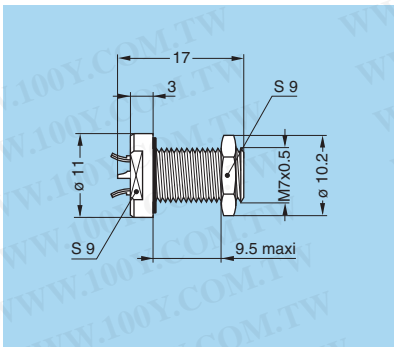

EWF Fixed socket, nut fixing, watertight or vacuumtight (back panel mounting)

Part number	Weight (g)
EWF.00.250.NTLP	4.2
EWF.00.250.NTLPV	4.2

P1 Panel cut-out (page 38)

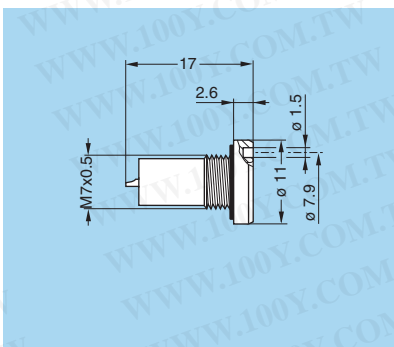
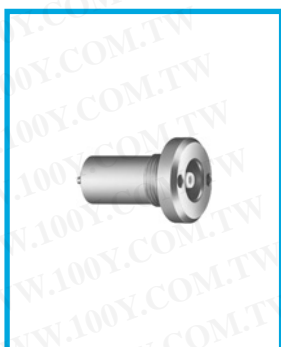

EWV Fixed socket, watertight or vacuumtight

Part number	Weight (g)
EWV.00.250.NTLP	3.7
EWV.00.250.NTLPV	3.7

P2 Panel cut-out (page 38)

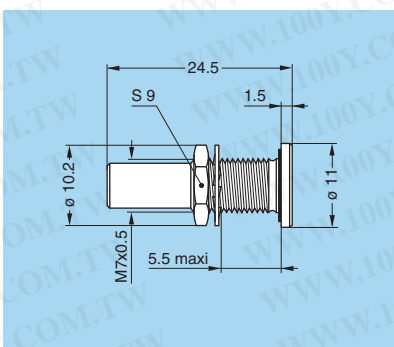

SWH Fixed coupler, nut fixing, vacuumtight

Part number	Weight (g)
SWH.00.250.NTMV	5.2

P1 Panel cut-out (page 38)

Note: this model is sealed with o-rings (no epoxy).

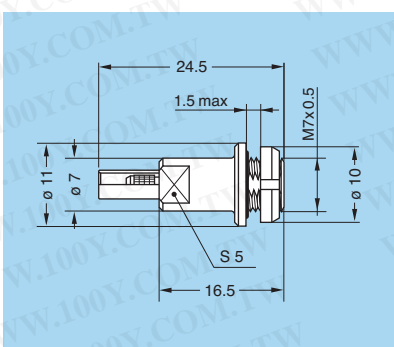

VPS Fixed socket, short shell, vacuumtight with cable crimping (back panel mounting)

Part number	Cable group	Cond. Ø		Dielectric Ø maxi	Sheath Ø maxi
		mini	maxi		
VPS.00.250.CTLE31	3-4	0.46	0.55	1.65	3.0

P1 Panel cut-out (page 38)

Cable assembly, please contact customer service

勝特力材料 886-3-5753170
 勝特力电子(上海) 86-21-34970699
 勝特力电子(深圳) 86-755-83298787
[Http://www.100y.com.tw](http://www.100y.com.tw)

Metal housing models with mechanical keying

The straight plug and receptacle models FSG, XBG, XRG, XSG, ESG, EXG and PSG are available with a key to avoid cross mating of similar connectors. These models are not included in the NIM-CAMAC standard.

The standard "G" key consists of one mechanical alignment key.

Front view of the standard "G" key



勝特力材料 886-3-5753170
 勝特力电子(上海) 86-21-34970699
 勝特力电子(深圳) 86-755-83298787
[Http://www.100y.com.tw](http://www.100y.com.tw)



FSG Straight plug with key (G), with cable crimping

Part number	Dim		Cable group	Cond. Ø maxi	Dielec. Ø maxi	Sheath Ø maxi
	L	M				
FSG.00.250.NTAE24	31	23	1	0.4	0.95	2.35
FSG.00.250.NTAE31	31	23	3-4	0.55	1.65	3.0
FSG.00.250.NTAE52	34	26	6	0.97	3.05	5.2

M5 Cable assembly, solder contact (page 41)

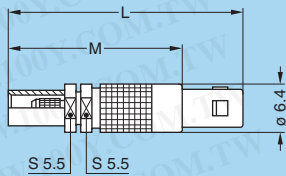

Part number	Dim		Cable group	Cond. Ø		Dielec. Ø maxi	Sheath Ø maxi
	L	M		mini	maxi		
FSG.00.250.NTCE24	31	23	1	0.28	0.4	0.95	2.35
FSG.00.250.NTCE31	31	23	3-4	0.46	0.55	1.65	3.0
FSG.00.250.NTCE52	34	26	6	0.90	0.97	3.05	5.2

M4 Cable assembly, crimp contact (page 40)

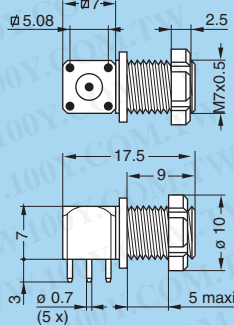

XBG Elbow socket (90°) with slotted nut, for printed circuit with key (G)

Part number	Weight (g)
XBG.00.250.NTN	5.1

P1 Panel cut-out (page 38)

P12 PCB drilling pattern (page 38)

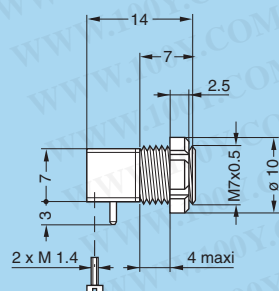

XRG Elbow socket (90°), with key (G), short shell and slotted nut, for printed circuit, screw fixing (back panel mounting)

Part number	Weight (g)
XRG.00.250.NTN	3.8

P1 Panel cut-out (page 38)

P14 PCB drilling pattern (page 38)

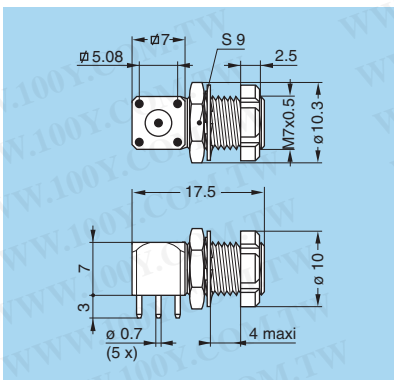

XSG Elbow socket (90°) with slotted with key (G), and hex nuts for printed circuit

Part number	Weight (g)
XSG.00.250.NTN	5.4

- P1** Panel cut-out (page 38)
- P12** PCB drilling pattern (page 38)

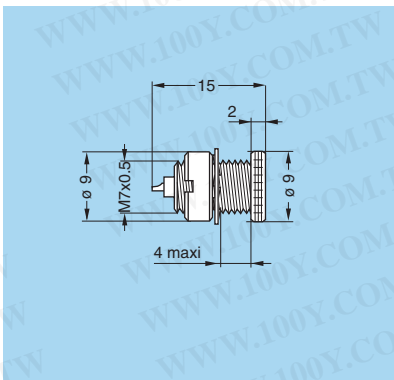

ESG Fixed socket with two round nuts, threaded shell, with key (G) (back panel mounting)

Part number	Weight (g)
ESG.00.250.NLL	3.1

- P1** Panel cut-out (page 38)

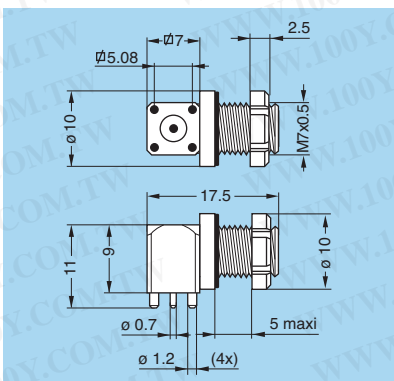

EXG Elbow socket (90°) with slotted nut for printed circuit, with key (G), with o-ring on flange (back panel mounting). Special shell design.

Part number	Weight (g)
EXG.00.250.NTNY	6.3

- P1** Panel cut-out (page 38)
- P15** PCB drilling pattern (page 38)

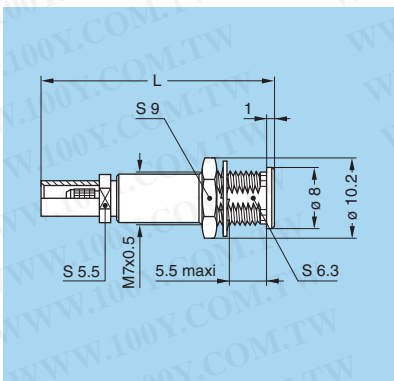

PSG Fixed socket, nut fixing, with key (G) with cable crimping

Part number	Dim L	Cable group	Cond. Ø		Dielec. Ø maxi	Sheath Ø maxi
			mini	maxi		
PSG.00.250.NTME24	30	1	0.28	0.4	0.95	2.35
PSG.00.250.NTME31	30	3-4	0.46	0.55	1.65	3.0
PSG.00.250.NTME52	33	6	0.90	0.97	3.05	5.2

- M4** Cable assembly, crimp contact (page 40)
- P5** Panel cut-out (page 38)

勝特力材料 886-3-5753170
 勝特力电子(上海) 86-21-34970699
 勝特力电子(深圳) 86-755-83298787
[Http://www.100y.com.tw](http://www.100y.com.tw)

Threaded-coupling models

The straight plug and receptacle models FVS, EPE and EPS are available with threaded coupling. On sockets, 3.2 mm minimum length of free threading must be available to ensure screw mating. These models are not included in the NIM-CAMAC standard.



FVS Straight plug for cable crimping

Part number	Dim		Cable group	Cond. Ø maxi	Dielec. Ø maxi	Sheath Ø maxi
	L	M				
FVS.00.250.NTAE24	31	23	1	0.4	0.95	2.35
FVS.00.250.NTAE31	31	23	3-4	0.55	1.65	3.0
FVS.00.250.NTAE52	34	26	6	0.97	3.05	5.2

M5 Cable assembly, solder contact (page 41)

Part number	Dim		Cable group	Cond. Ø		Dielec. Ø maxi	Sheath Ø maxi
	L	M		mini	maxi		
FVS.00.250.NTCE24	31	23	1	0.28	0.4	0.95	2.35
FVS.00.250.NTCE25	31	23	1	0.28	0.4	1.15	2.35
FVS.00.250.NTCE30	31	23	2	0.28	0.4	1.65	3.0
FVS.00.250.NTCE31	31	23	3-4	0.46	0.55	1.65	3.0
FVS.00.250.NTCE35	31	23	8	0.46	0.55	1.65	3.35
FVS.00.250.NTCE44	31	23	5	0.28	0.4	2.65	4.35
FVS.00.250.NTCE52	34	26	6	0.90	0.97	3.05	5.2
FVS.00.250.NTCE56	34	26	7	0.90	0.97	3.05	5.45

M4 Cable assembly, crimp contact (page 40)

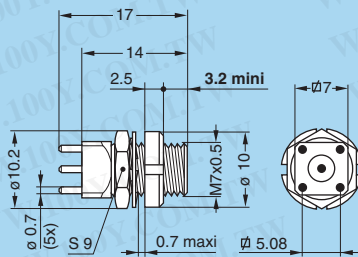
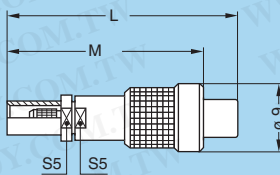

EPE Straight socket with two nuts, for printed circuit

Part number	Weight (g)
EPE.00.250.NTN	4.3

P1 Panel cut-out (page 38)

P12 PCB drilling pattern (page 38)

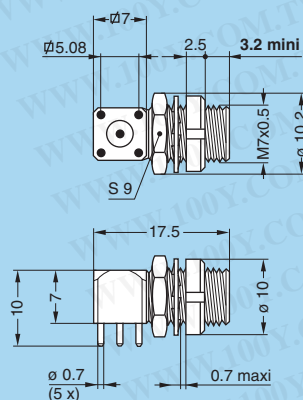

EPS Elbow socket (90°) with two nuts, for printed circuit

Part number	Weight (g)
EPS.00.250.NTN	5.4

P1 Panel cut-out (page 38)

P12 PCB drilling pattern (page 38)



Adaptors

ABF Adaptor from LEMO plug to BNC socket

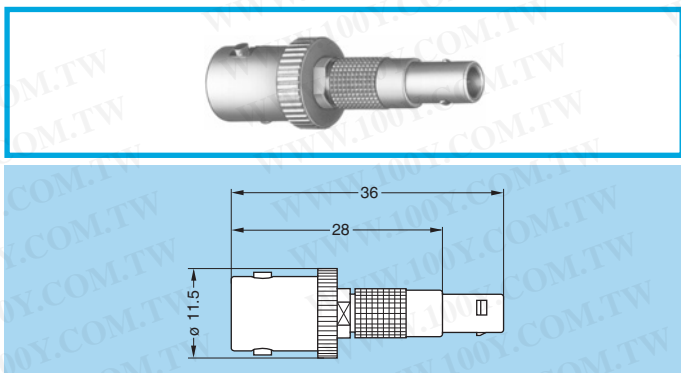

Part number	Weight (g)
ABF.00.250.NTA	8.3

APF Adaptor from LEMO plug to CINCH socket

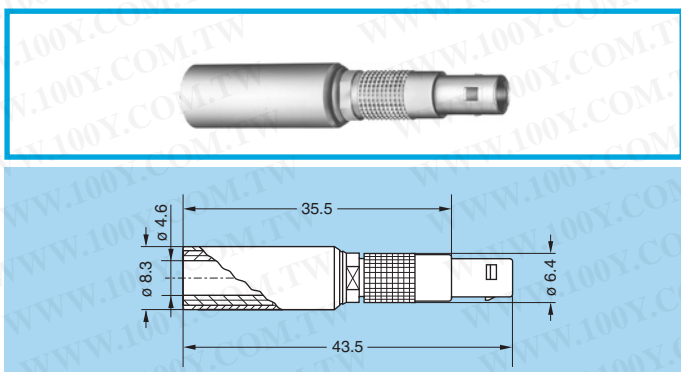

Part number	Colour of the ring	Weight (g)
APF.00.250.DTAB	white	7
APF.00.250.DTAR	red	7

ABA Adaptor from LEMO socket to BNC plug

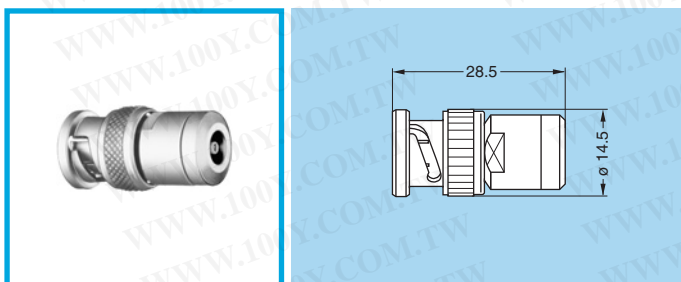

Part number	Weight (g)
ABA.00.250.NTL	18.7

ABC Adaptor from LEMO socket to BNC socket

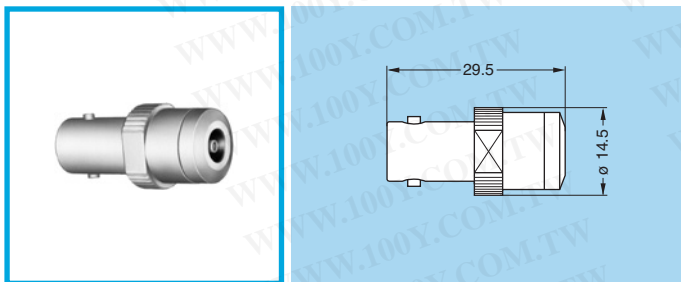

Part number	Weight (g)
ABC.00.250.NTM	17

ABD Adaptor from LEMO socket to BNC fixed socket

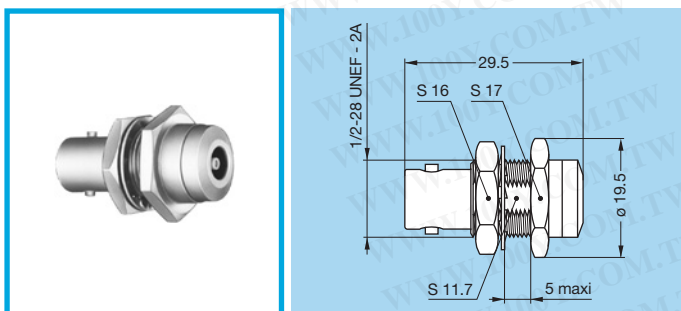

Part number	Weight (g)
ABD.00.250.NTM	21.4

P7 Panel cut-out (page 38)

勝特力材料 886-3-5753170
 勝特力电子(上海) 86-21-34970699
 勝特力电子(深圳) 86-755-83298787
[Http://www.100y.com.tw](http://www.100y.com.tw)



ABB Adaptor from LEMO fixed socket to BNC socket

Part number	Weight (g)
ABB.00.250.NTM	9.4

P6 Panel cut-out (page 38)

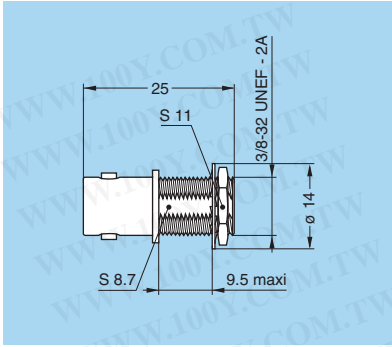
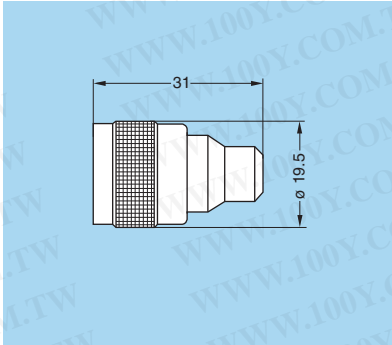

ACA Adaptor from LEMO socket to C plug

Part number	Weight (g)
ACA.00.250.NTL	32

Note: Non standard, on request only

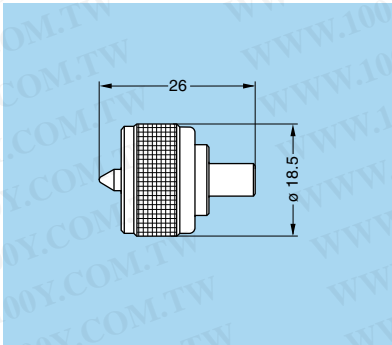

AGH Adaptor from LEMO socket to UHF plug

Part number	Weight (g)
AGH.00.250.NTL	13.8

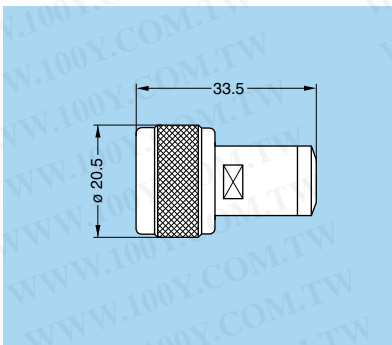

ANA Adaptor from LEMO socket to N plug

Part number	Weight (g)
ANA.00.250.NTL	38

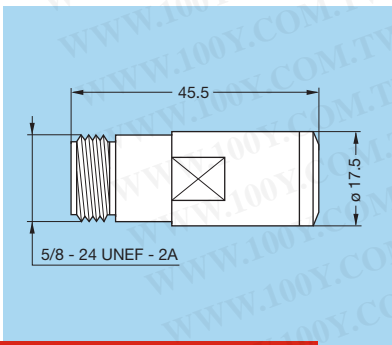

ANB Adaptor from LEMO socket to N socket

Part number	Weight (g)
ANB.00.250.NTM	61.7

Note: Non standard, on request only

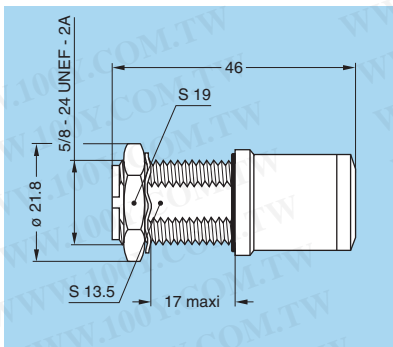

ANC Adaptor from LEMO socket to N fixed socket

Part number	Weight (g)
ANC.00.250.NTM	63.5

P8 Panel cut-out (page 38)

Note: Non standard, on request only

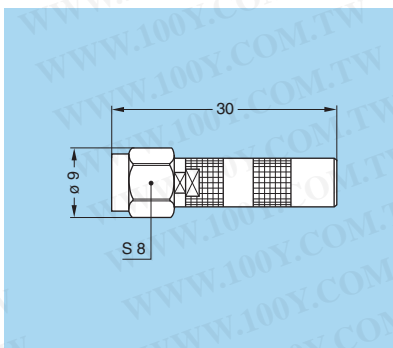

ASA Adaptor from LEMO socket to SMA plug

Part number	Weight (g)
ASA.00.250.NTL	4.9

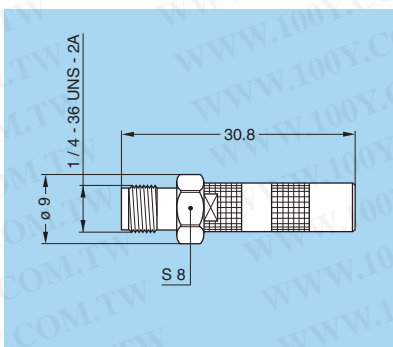

ASB Adaptor from LEMO socket to SMA socket

Part number	Weight (g)
ASB.00.250.NTM	4.6

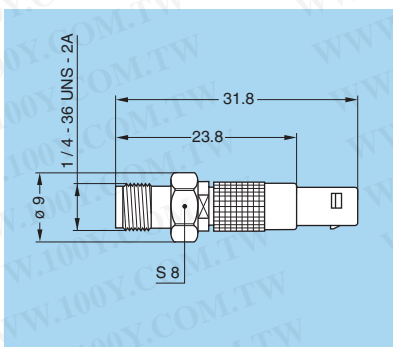

ASF Adaptor from LEMO plug to SMA socket

Part number	Weight (g)
ASF.00.250.NTA	4.6

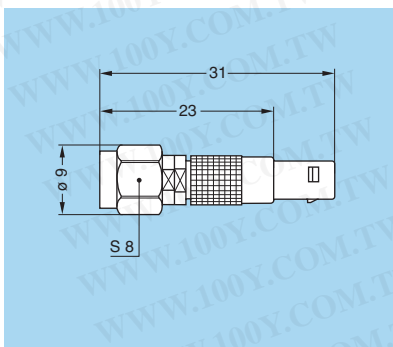

ASG Adaptor from LEMO plug to SMA plug

Part number	Weight (g)
ASG.00.250.NTC	4.9

Variant

Bend relief for models with collet (letter Z in the variant position)



Reference	Need to be ordered separately (see page 33)
C15Z	GMA.00.0●●.D●
C17Z	GMA.00.0●●.D●
C22Z	-
C27Z	GMD or GMB.00.0●●.D●
C31Z	GMD or GMB.00.0●●.D●
C52Z	GMA.0B.0●●.D●
K37Z	GMA.0B.0●●.D●
K42Z	GMA.0B.0●●.D●
D42Z	GMA.0B.0●●.D●
D52Z	GMA.0B.0●●.D●

Note: The "GMD" are thin bend reliefs (for very flexible cables)

Bend relief for models for cable crimping (no letter in the variant position)
The bend relief can be fitted directly over the crimp ferrule



Reference	Need to be ordered separately (see page 33)
E24	GMD or GMB.00.0●●.D●
E25	GMD or GMB.00.0●●.D●
E30	GMD or GMB.00.0●●.D●
E31	GMD or GMB.00.0●●.D●
E32	GMD or GMB.00.0●●.D●
E35	-
E44	-
E52	-
E56	-

勝特力材料 886-3-5753170
 勝特力电子(上海) 86-21-34970699
 勝特力电子(深圳) 86-755-83298787
[Http://www.100y.com.tw](http://www.100y.com.tw)

Note: The "GMD" are thin bend reliefs (for very flexible cables)

Assembled cables

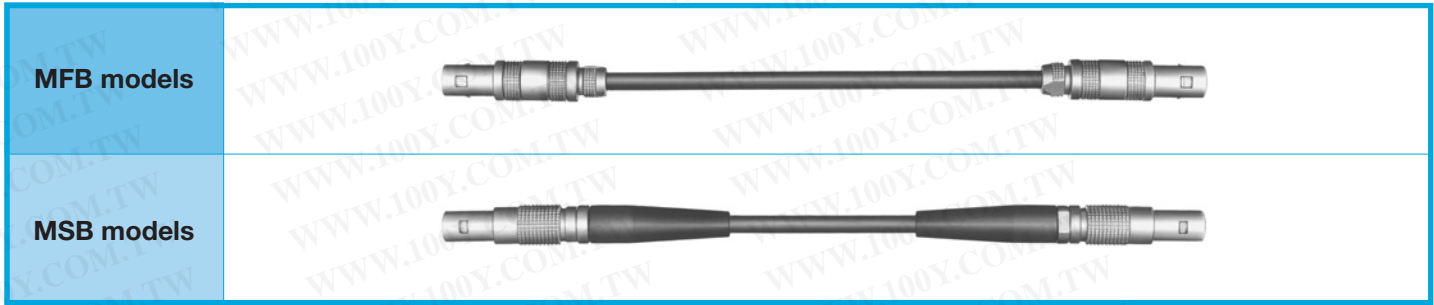

Delay lines

Part number	Delay (ns)	Part number
MFB.00.250.RTE005	0.5	MSB.00.250.RTE005
MFB.00.250.RTE010	1.0	MSB.00.250.RTE010
MFB.00.250.RTE020	2.0	MSB.00.250.RTE020
MFB.00.250.RTE030	3.0	MSB.00.250.RTE030
MFB.00.250.RTE040	4.0	MSB.00.250.RTE040
MFB.00.250.RTE050	5.0	MSB.00.250.RTE050
MFB.00.250.RTE060	6.0	MSB.00.250.RTE060
MFB.00.250.RTE080	8.0	MSB.00.250.RTE080
MFB.00.250.RTE100	10.0	MSB.00.250.RTE100
MFB.00.250.RTE160	16.0	MSB.00.250.RTE160
MFB.00.250.RTE200	20.0	MSB.00.250.RTE200
MFB.00.250.RTE320	32.0	MSB.00.250.RTE320
MFB.00.250.RTE640	64.0	MSB.00.250.RTE640

Assembled Cables

Part number	Length (cm)	Part number
MFB.00.250.LTE010	10	MSB.00.250.LTE010
MFB.00.250.LTE020	20	MSB.00.250.LTE020
MFB.00.250.LTE030	30	MSB.00.250.LTE030
MFB.00.250.LTE040	40	MSB.00.250.LTE040
MFB.00.250.LTE050	50	MSB.00.250.LTE050
MFB.00.250.LTE060	60	MSB.00.250.LTE060
MFB.00.250.LTE080	80	MSB.00.250.LTE080
MFB.00.250.LTE100	100	MSB.00.250.LTE100
MFB.00.250.LTE150	150	MSB.00.250.LTE150
MFB.00.250.LTE200	200	MSB.00.250.LTE200
MFB.00.250.LTE300	300	MSB.00.250.LTE300
MFB.00.250.LTE400	400	MSB.00.250.LTE400
MFB.00.250.LTE500	500	MSB.00.250.LTE500

Note: the standard cable used to manufacture these cable assemblies is according to IEC.50.2.1 standard. On request this type of cable can be replaced by other coaxial cables. Other cable lengths are available on request.

Accessories



Fitting of the cord

Slide the plug into the loop of the cord. Place the loop into the groove in front of the collet nut and tighten the loop.

BFG Caps for plug with or without keying

Part number	Weight (g)
BFG.00.100.PCSG	0.7

Note: upon request this cap can be supplied in black and the last letter "G" of the part number should be replaced with "N".

- Body material: Polyoxymethylen (POM) grey
- Cord material: Polyamid 6, grey
- O-ring material: Silicone rubber
- Maximum operating temperature: 100°C
- Watertightness: IP61 according to IEC 60529

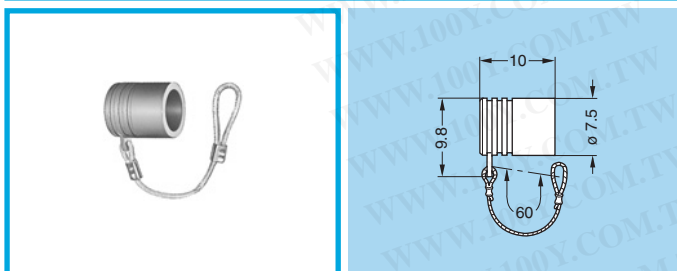

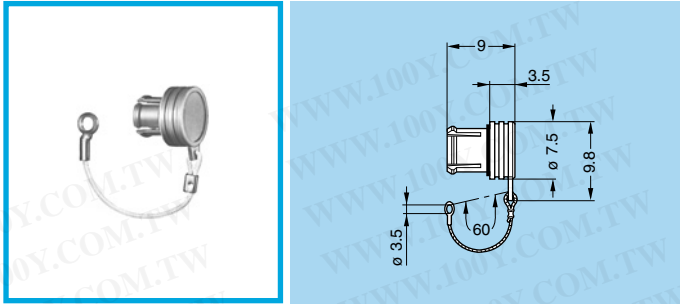

- Body material: Polyoxymethylen (POM) grey
- Cord material: Polyamid 6, grey

BRA Blanking cap for fixed socket and free straight socket

Part number	Weight (g)
BRA.00.200.PCSG	0.6

Note: upon request this cap can be supplied in black and the last letter "G" of the part number should be replaced with "N".

- O-ring material: Silicone rubber
- Maximum operating temperature: 100°C
- Watertightness: IP61 according to IEC 60529

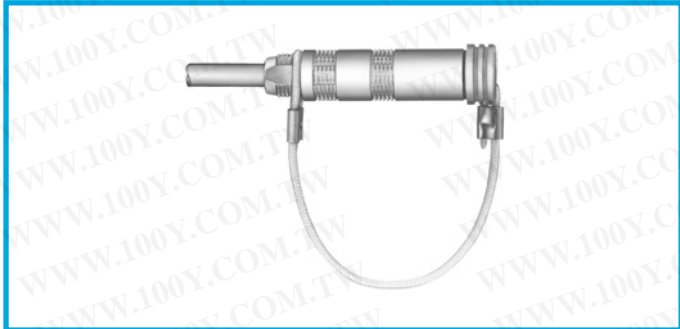

Fitting of the cord

Slide the socket into the loop of the cord. Place the loop into the groove in front of the collet nut and tighten the loop.

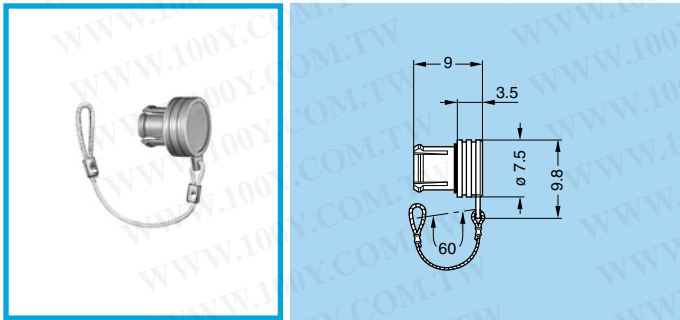

BRD Blanking cap for free socket

Part number	Weight (g)
BRD.00.200.PCSG	0.5

Note: upon request this cap can be supplied in black and the last letter "C" of the part number should be replaced with "N".

- Body material: Polyoxymethylen (POM) grey
- Cord material: Polyamid 6, grey
- O-ring material: Silicone rubber
- Maximum operating temperature: 100°C
- Watertightness: IP61 according to IEC 60529

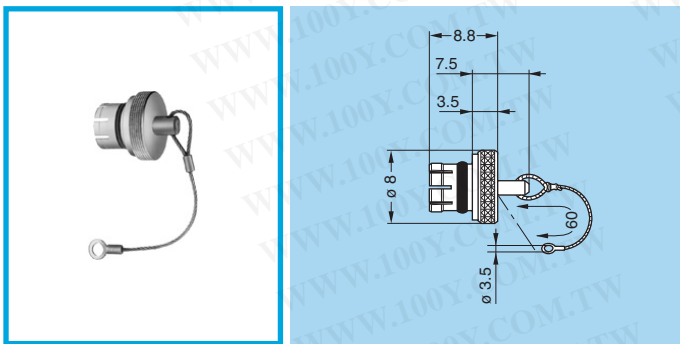

BRE Blanking cap for fixed socket, free socket and coupler

Part number	Weight (g)
BRE.00.200.NAS	6.5

- Body material: Brass (UNS C 38500), nickel-plated (3 µm)
- Cable material: Stainless steel
- O-ring material: Silicone rubber or FPM
- Maximum operating temperature: 250°C
- Watertightness: IP61 according to IEC 60529

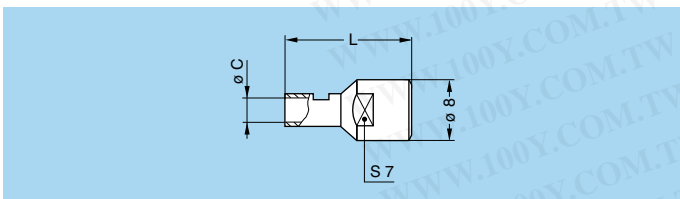

GCD Earthing cap

Part number	Cable group	Dim.	
		L	C
GCD.00.020.LA	1	12	2.0
GCD.00.032.LA	2-3-4	16	3.2
GCD.00.050.LA	6	19	5.0

Note: the shield braid of the cable should be soldered onto the back of the cap screwed on the socket outer shell.

- Material: Brass (UNS C 38500) gold-plated (0.5 µm)

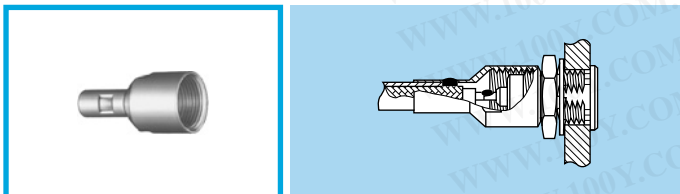

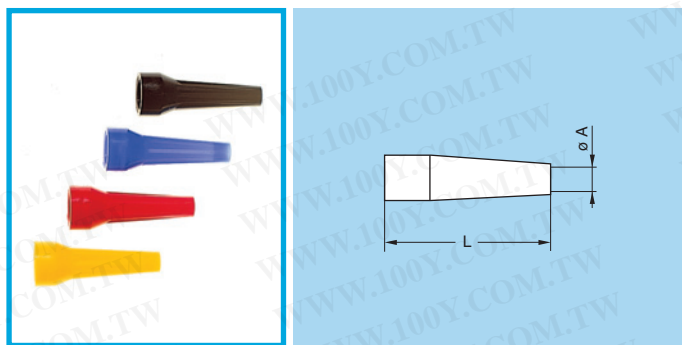

GM• Bend relief (Polyurethane)

Part number	Dim.		ø Cable		Nut for fitting the bend relief part nb
	A	L	max	min	
GMA.00.012.D●	1.2	22	1.4	1.1	FFM.00.130.LN
GMA.00.018.D●	1.8	22	2.1	1.8	FFM.00.130.LN
GMB.00.025.D●	2.5	22	2.8	2.5	FFM.00.130.LN
GMB.00.028.D●	2.8	22	3.1	2.8	FFM.00.130.LN
GMB.00.032.D●	3.2	22	3.5	3.2	FFM.00.130.LN
GMD.00.025.D●	2.5	22	2.8	2.5	FFM.00.130.LN
GMD.00.028.D●	2.8	22	3.1	2.8	FFM.00.130.LN
GMD.00.032.D●	3.2	22	3.5	3.2	FFM.00.130.LN
GMA.0B.025.D●	2.5	24	2.9	2.5	FFM.0B.130.LC
GMA.0B.030.D●	3.0	24	3.4	3.0	FFM.0B.130.LC
GMB.0B.035.D●	3.5	24	3.9	3.5	FFM.0B.130.LC
GMB.0B.040.D●	4.0	24	4.4	4.0	FFM.0B.130.LC
GMB.0B.045.D●	4.5	24	5.2	4.5	FFM.0B.130.LC

Note:

- a) for use with crimp models and nut for fitting a bend relief.
- b) the last letter of the part number "●" specifies the colour. Refer to the table below, for GRA washers, to define another colour and replace the letter "●" by the one corresponding to the colour required.
- c) material: Polyurethan (Desmopan 786)
- d) operating temperature: -40°C + 80°C

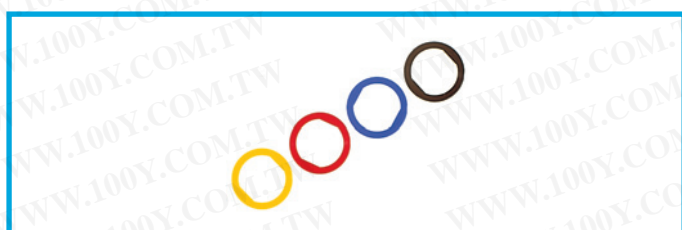

GRA Insulating washers

Part number	Weight (g)
GRA.00.269.G●	0.1

Note:

- a) sockets and plugs mounted on panels can be fitted with insulating washers. The nine colours available combined with those for the bend reliefs makes colour coding possible.
- b) the last letter of the part number "●" specifies the colour. Refer to the table below to define another colour and replace the letter "●" by the one corresponding to the colour required.
- c) material: Polyamid
- d) operating temperature: -40°C + 80°C

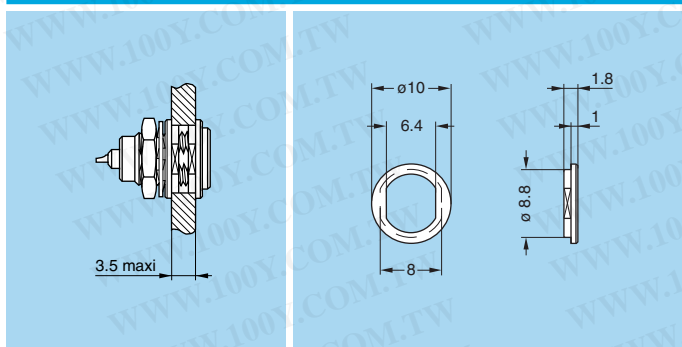

Ref.	Colour	Ref.	Colour	Ref.	Colour
A	blue	J	yellow	R	red
B	white	M	brown	S	orange
G	grey	N	black	V	green

勝特力材料 886-3-5753170
 勝特力电子(上海) 86-21-34970699
 勝特力电子(深圳) 86-755-83298787
[Http://www.100y.com.tw](http://www.100y.com.tw)

Spare Parts

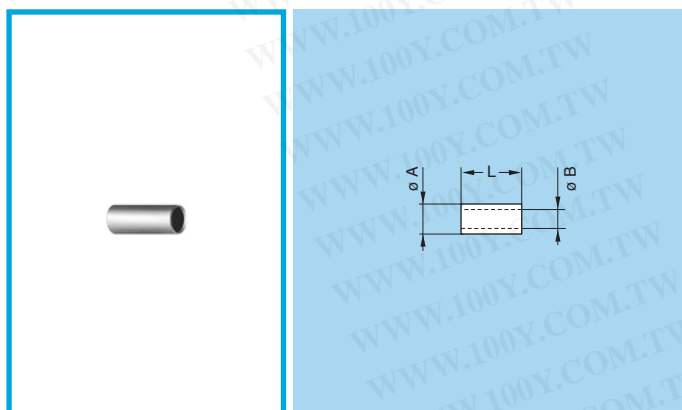

FFS Crimp ferrule

Part number	Cable group	Dim.		
		øA	øB	L
FFS.00.160.DN	1	3.1	2.4	8
FFS.00.161.MN	2-3-4	3.8	3.05	8
FFS.00.162.DN	8	4.4	3.4	8
FFS.00.163.DN	5	5.3	4.4	8
FFS.00.164.DN	6	6.2	5.25	11
CRK.0A.160.DN	7	6.2	5.5	11

Note: sockets and plugs to be crimped are always supplied with a crimp ferrule. To order this accessory separately, use the above part numbers.

● Material: Copper (UNS C 18700) nickel-plated (3µm)

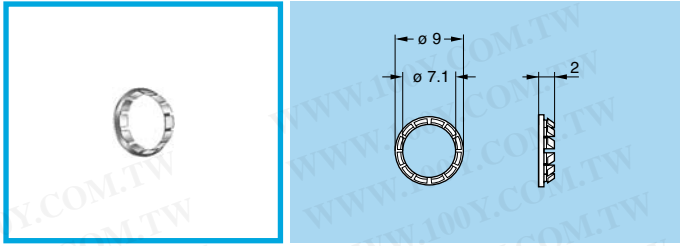

GBB Tapered washer

Part number	Weight (g)
GBB.00.250.LN	0.2

Note: to order this accessory separately, use the above part number.

- Material: Brass (UNS C 38500) nickel-plated (3 μ m)

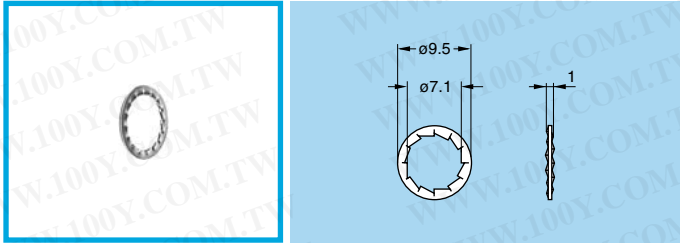

GBA Locking washer

Part number	Weight (g)
GBA.00.250.FN	0.2

Note: sockets and plugs are always supplied with a locking washer. To order this accessory separately, use the above part number.

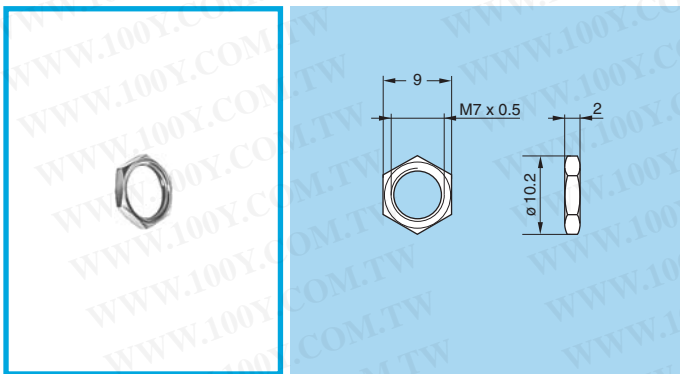

GEA Hexagonal nut

Part number	Weight (g)
GEA.00.240.LN	0.6

Note: sockets and plugs are supplied with a hexagonal nut as standard. To order this accessory separately, use the above part number. The last letters "LN" of the part number refer to the nut material and treatment. If a nut in aluminium alloy is desired, replace the last letters of the part number by "PT".

- Material:
 - Brass (UNS C 38500) nickel-plated (3 μ m)
 - Aluminium alloy natural anodized

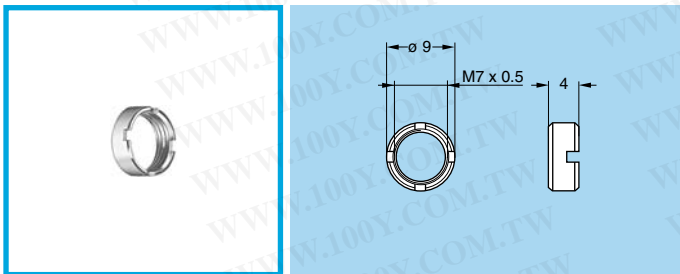

GEB Round nut

Part number	Weight (g)	Standard for models
GEB.00.240.LN	0.8	ECP, ESG

Note: to order this accessory separately, use the above part number.

- Material: Brass (UNS C 38500) nickel-plated (3 μ m)

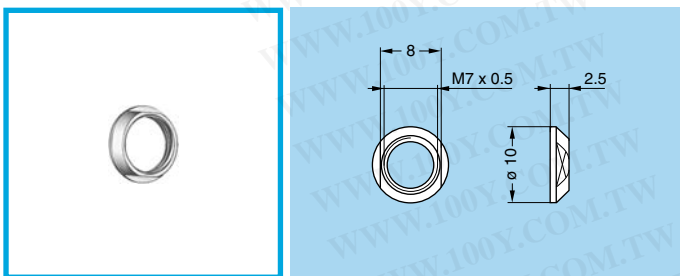

GEC Conical nut

Part number	Weight (g)
GEC.00.240.LN	0.6

勝特力材料 886-3-5753170
 勝特力电子(上海) 86-21-34970699
 勝特力电子(深圳) 86-755-83298787
[Http://www.100y.com.tw](http://www.100y.com.tw)

Note: to order this accessory separately, use the above part number.

- Material: Brass (UNS C 38500) nickel-plated (3 μ m)

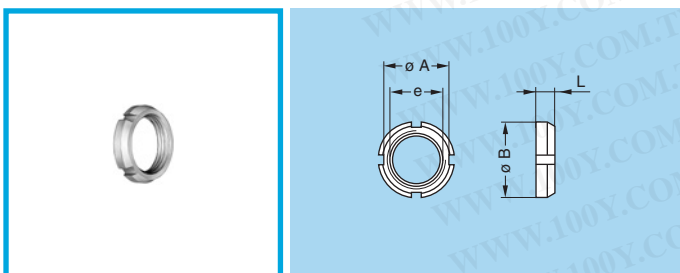

GEG Notched nut

Part number	Dimensions (mm)				Standard for models
	A	B	e	L	
GEG.00.240.LN	8.7	10	M7 x 0.5	2.5	EPE, EPS, EPR PES, PFS, PLK, VPS, HEP

Note: to order this accessory separately, use the above part numbers.

- Material: Brass (UNS C 38500) nickel-plated (3 μ m)

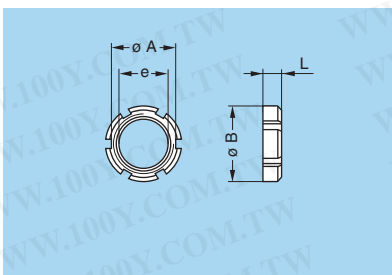

GEB Slotted nut

Part number	Dimensions (mm)				Standard for models
	A	B	e	L	
GEB.00.242.LN	8.5	10	M7 x 0.5	2.5	ELF, XBG, XRG, XSG, EXG

Note: to order this accessory separately, use the above part numbers.

- Material: Brass (UNS C 38500) nicked-plated (3 μ m)

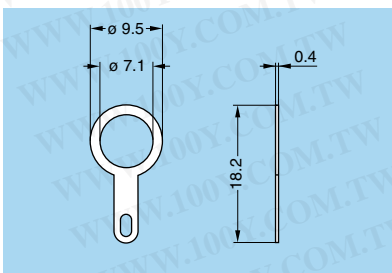

GCA Earthing Washer

Part number	Weight (g)
GCA.00.255.LT	0.2

- Material: Brass (UNS C 27400) treated CuSnZn (2 μ m)

Tooling

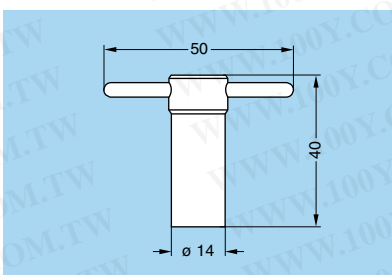
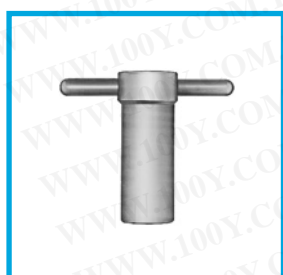

DCG Spanner for hexagonal nut

Part number	Part number of the nut
DCG.91.149.0TN	GEA.00.240.LN

- Material: Blackened steel

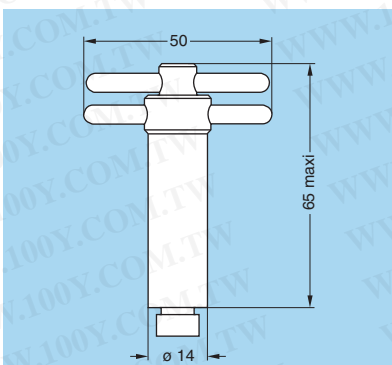
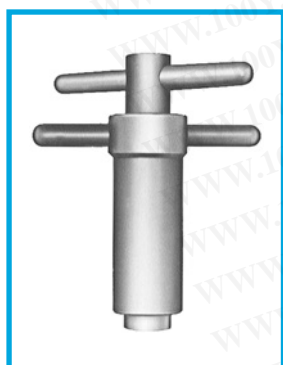

DCA Spanner for hexagonal nut with locator for flats on socket thread

Part number	Part number of the nut
DCA.91.149.0TN	GEA.00.240.LN

- Material: Blackened steel

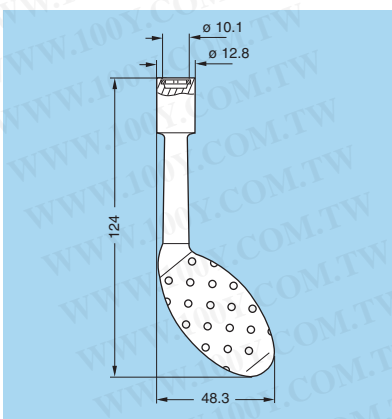

DCH Spanner for notched nut

Part number	Part number of the nut
DCH.91.101.PA	GEG.00.240.LN

- Material: blue polyurethane

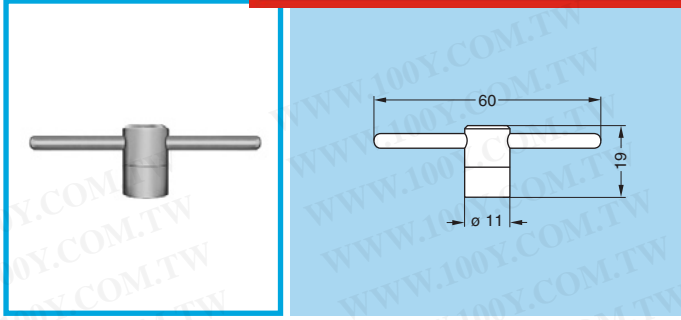

DCB Spanner for slotted nut

Part number	Part number of the nut
DCB.91.455.0LN	GEB.00.242.LN

- Material: Steel, nicked plated

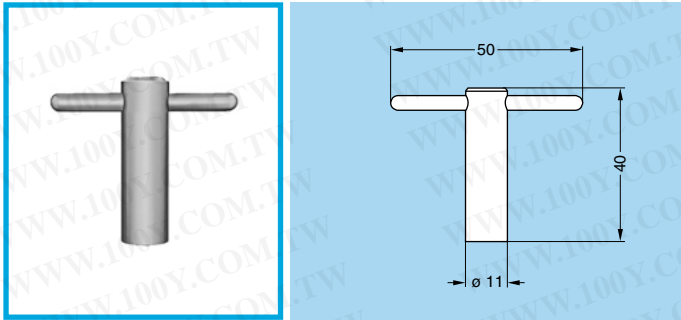

DCB Spanner for round nut

Part number	Part number of the nut
DCB.91.119.0TN	GEB.00.240.LN

- Material: Blackened steel

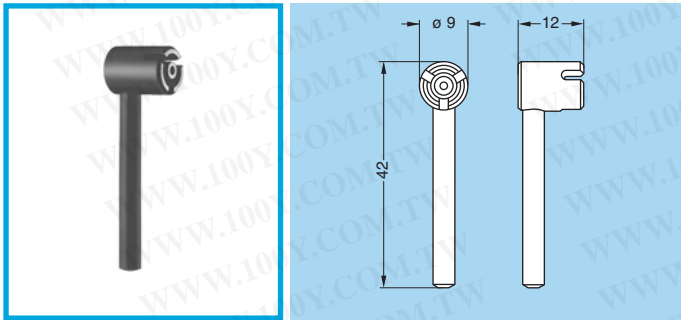

DCN Spanner for assembling plug with 3 latches

Part number
DCN.91.905.0TK

- Material: Blackened steel

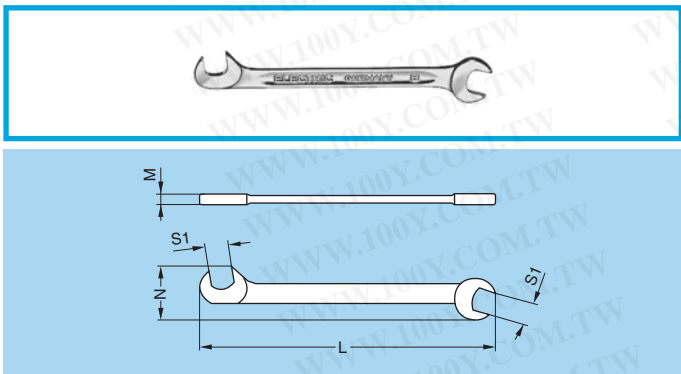

DCP Flat spanner for collet nut

Part number	Dimensions			
	L	M	N	S1
DCP.99.045.TC	70	2	10.5	4.5
DCP.99.050.TC	78	2	12.6	5.0
DCP.99.055.TC	78	2	12.6	5.5
DCP.99.060.TC	78	2	12.6	6.0

- Material: Chrome-plated steel

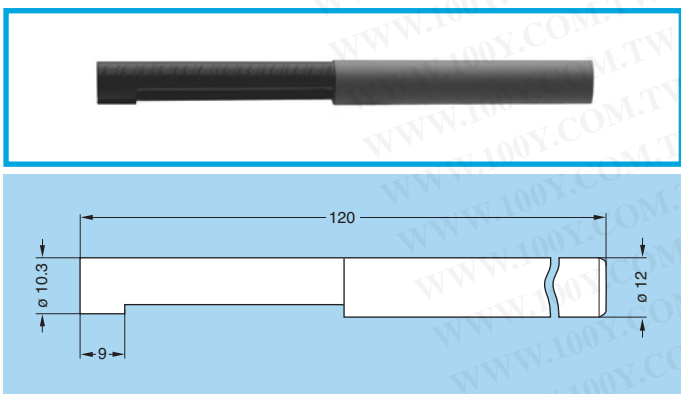

DCR Extraction tool for plugs

Part number
DCR.91.106.0PN

- Material: Black Polypropylene

Note: this type of tool has been produced in order to facilitate the mating and unmating of plugs and is particularly useful in high density applications.



DPE Crimping tool with die

Part number	Cable group	Crimp collet ref.
DPE.99.000.0K	Crimping tool with no die	
DPE.99.123.1K	1	E24
DPE.99.123.8K	2-3-4	E30, E31
DPE.99.124.3K	8	E35
DPE.99.125.2K	5	E44
DPE.99.176.2K	6-7	E52, E56



DPN Dies

Part number	Cable group	Die dimension				
		For contacts			For shield	
		A	B	L	A	B
DPN.99.123.1K	1	1.29	0.91	2.0	3.10	2.70
DPN.99.123.8K	2-3-4	1.29	0.91	2.0	3.80	3.30
DPN.99.124.3K	8	1.29	0.91	2.0	4.36	3.78
DPN.99.125.2K	5	1.29	0.91	2.0	5.20	4.50
DPN.99.176.2K	6-7	1.71	1.21	2.5	6.20	5.37

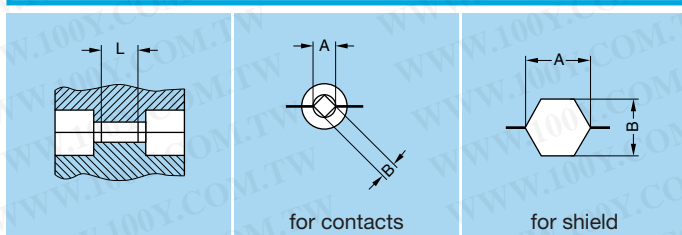

● Dies material: Blackened steel

勝特力材料 886-3-5753170
 勝特力电子(上海) 86-21-34970699
 勝特力电子(深圳) 86-755-83298787
[Http://www.100y.com.tw](http://www.100y.com.tw)

Panel cut-outs

Panel cut-out

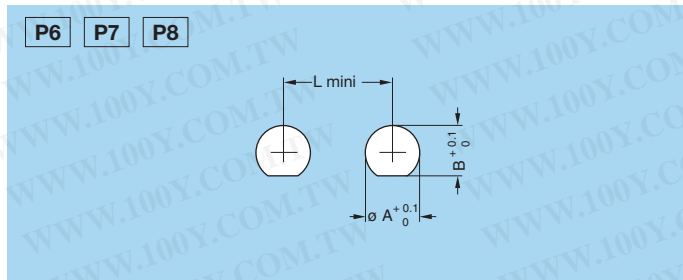
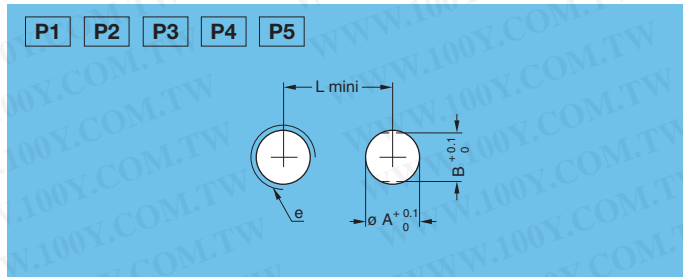

Cut-out	Model	Dimensions			
		A	B	L	e
P1	ECP-EPE-EPR-EPS-ERC EWF-EXG-FAB-HGP HGW-SWH-VPS-XBG XSG-XRG	7.1	-	14.5	-
P2	EWV	-	-	12.0	M7x0.5
P3	ERC-ERX	-	-	9.0	M7x0.5
P4	ERT	6.92 ^{+0.02}	-	-	-
P5	EHP-ELF-ERA-ERE-ERM ERN-FAA-FAN-PES-PFS PLK-PSA-PSG-PSS ¹⁾	7.1	6.4	14.5	-
P6	ABB	9.7	9.0	15.0	-
P7	ABD	12.9	11.7	20.5	-
P8	ANC	16.1	13.7	24.0	-

Note: 1) If these models are used with a tapered washer GBB, the panel cut-out must be according P1.

Recommended mounting nut torque: 1 Nm.

PCB drilling pattern

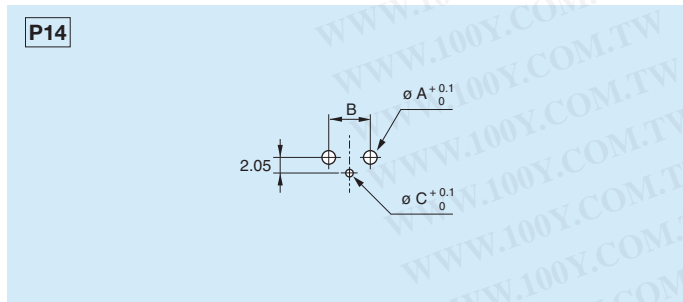
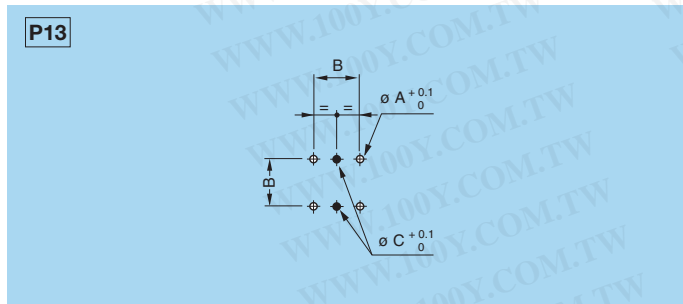
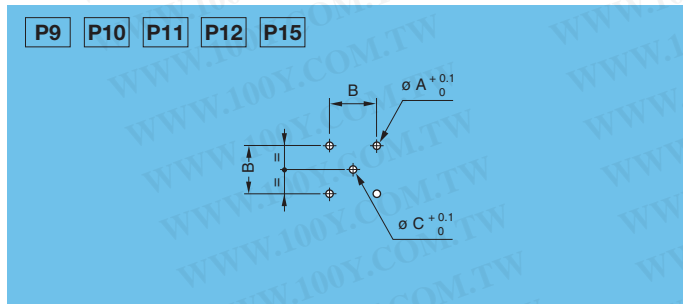

Drill	Model	Dimensions		
		A	B	C
P9	EPN	1.0	5.08	-
P10	EPA-EPB-EPC-EPL-EPK EPM-FPL	0.8	5.08	0.8
P11	FPA	0.8	5.08	1.1
P12	EPE-EPS-EPR-XSG	0.8	5.08	0.8
P15	HEP, EXG	1.3	5.08	0.8
P13	EPY	0.8	5.08	0.8
P14	XRG	1.8	5.5	0.8

勝特力材料 886-3-5753170
 勝特力电子(上海) 86-21-34970699
 勝特力电子(深圳) 86-755-83298787
[Http://www.100y.com.tw](http://www.100y.com.tw)

Cable assembly

Terminating of plugs and straight sockets with cable collet M1 M2 M3

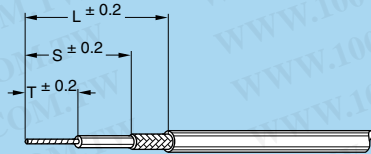
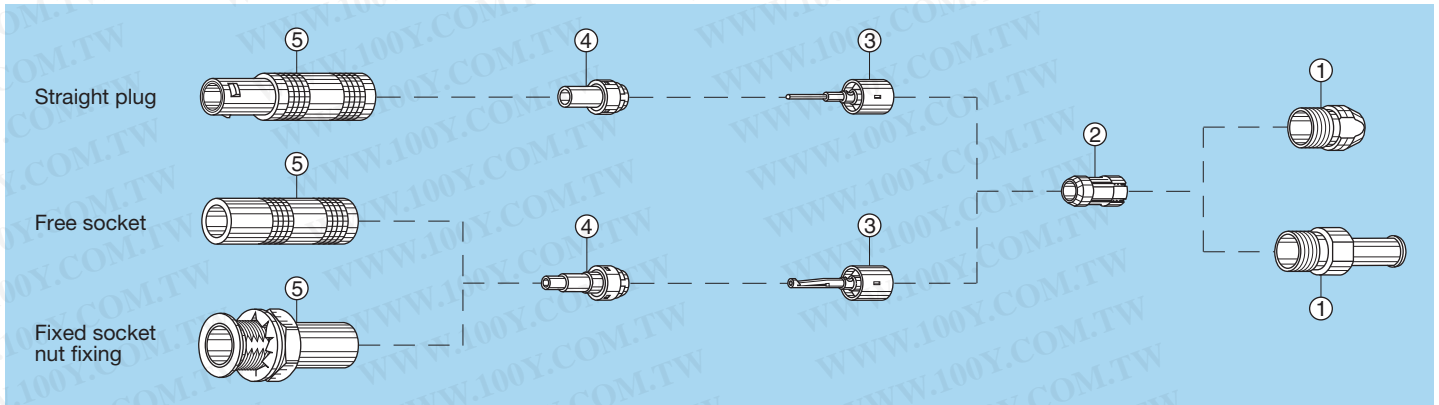

1. Cable preparation

First place the bend relief (if to be used) on the cable. Strip the cable according to dimensions below.

Cable group	M1			M2			M3		
	T	S	L	T	S	L	T	S	L
1-2-3-4-8	4	4.5	8	-	-	-	5	5	8
6-7	-	-	-	7.5	8.5	13	-	-	-

2. Cable termination

- 2.1 Place the collet nut ① and the collet ② on the cable. Fold back the shield braid onto the conical part of the collet, and trim to the outer edge of the collet
- 2.2 Slide the subassembly ③ to trap the shield braiding and solder the central conductor into the contact.
- 2.3 Slide the insulator ④ onto the subassembly ③ until it rests against the earthing sleeve of the subassembly ③.
- 2.4 Slide the assembly into the connector outer shell ⑤. Screw the collet nut ① into the connector outer shell ⑤ using the appropriate tool and tighten to a torque of 0.25 Nm (see "Tooling" on page 35, 36 and 37). Push the bend relief (if used) onto the collet nut.

Note: these terminating instructions apply to the following models:
 M1 = FFA, FFE, FFF, PCA, PSA
 M2 = FFY
 M3 = FFC

Terminating of plugs and straight sockets with cable crimping (crimp contact) M4

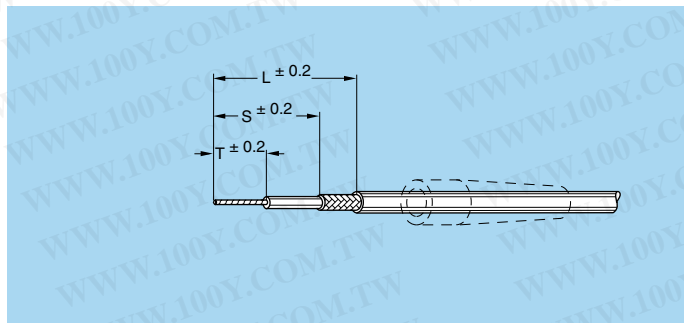
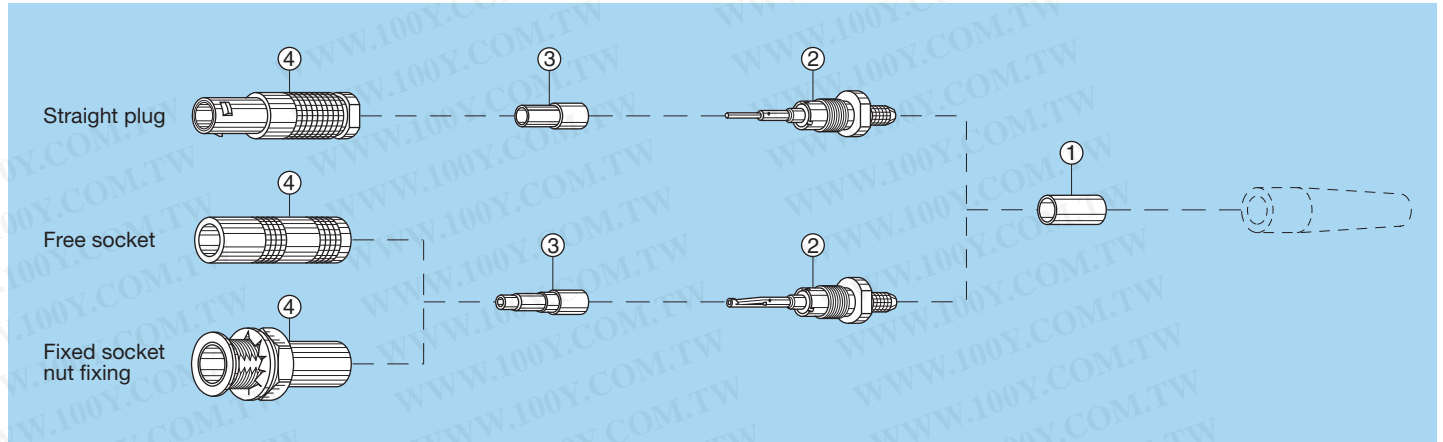

1. Cable preparation

First place the bend relief (if to be used) on the cable. Strip the cable according to dimensions below.

Cable group	M4		
	T	S	L
1-2-3-4-8	7	15	19.5
6-7	7	15	21.5

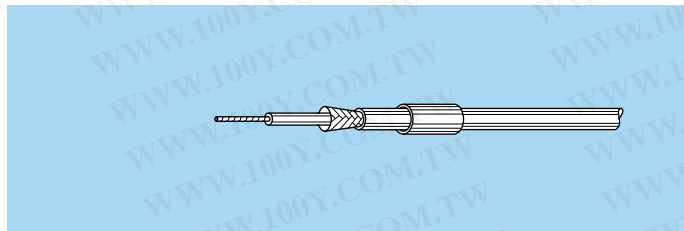

2. Cable termination

2.1 Place crimp ferrule ① on the cable. Widen the shield braid. Slide the subassembly ② into the cable until the insulator rests against the dielectric and the cable conductor is visible through the contact inspection hole.

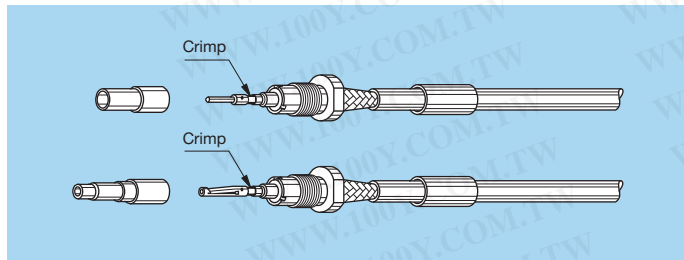

2.2 Crimp the contact with the LEMO crimping tool using the square hole (see "Tooling" on page 37). Gently pull the cable in order to check the crimping.

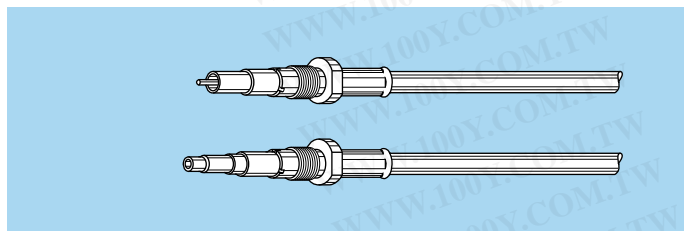

2.3 Slide the crimp ferrule ① onto the shield until it rests against the crimp backnut of the subassembly ②. Crimp with the same LEMO crimping tool using the hexagonal opening. Slide the insulator ③ onto the subassembly ②.

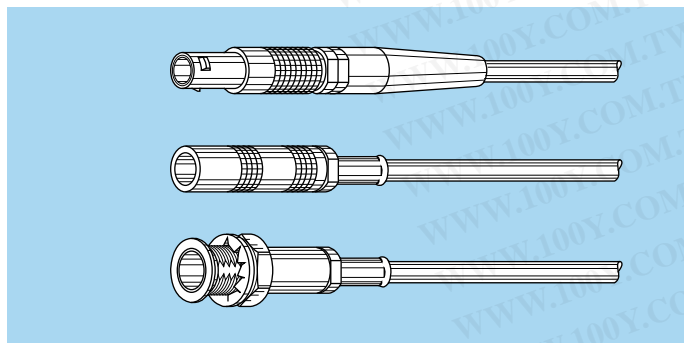

2.4 Slide the assembly into the connector shell ④ and screw it onto the subassembly ②. Tighten using the appropriate tool to a torque of 0.25 Nm (see "Tooling" on page 35, 36 and 37). Push the bend relief (if used) onto the crimp ferrule ①.

Note: these terminating instructions apply to the following models:
M4 = FFS, FFV, PCS, PSS, PES

Terminating of plugs and straight sockets with cable crimping (solder contact) **M5**

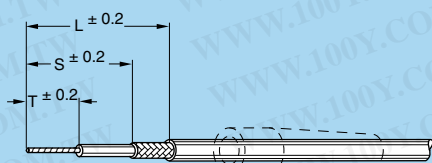
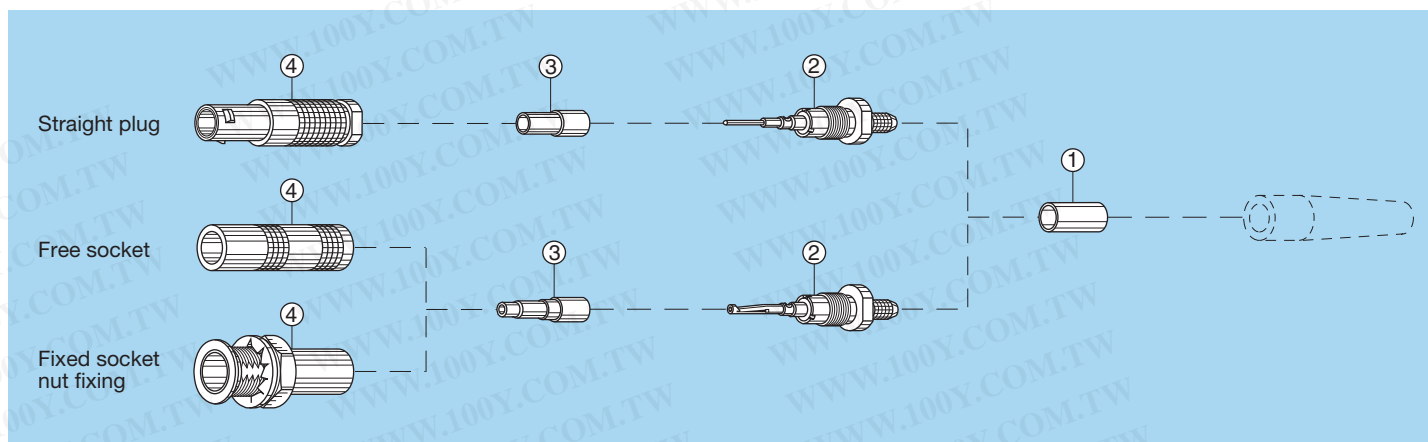

1. Cable preparation

First place the bend relief (if to be used) on the cable. Strip the cable according to dimensions below.

Cable group	M5		
	T	S	L
1-2-3-4-8	5	12	17
6-7	5	12	19

2. Cable terminating

2.1 Place the crimp ferrule ① on the cable. Widen the shield braid. Slide the subassembly ② over the cable until the insulator rests against the dielectric and the cable conductor is visible through the contact solder hole.

2.2 Solder the conductor through the hole.

勝特力材料 886-3-5753170
 勝特力电子(上海) 86-21-34970699
 勝特力电子(深圳) 86-755-83298787
[Http://www.100y.com.tw](http://www.100y.com.tw)

2.3 Slide the crimp ferrule ① onto the shield until it rests against the crimp backnut of the subassembly ②. Crimp with the LEMO crimping tool using the hexagonal opening (see "Tooling" on page 37). Slide the insulator ③ onto the subassembly ②.

2.4 Slide the assembly into the connector shell ④ and screw it onto the subassembly ②. Tighten using the appropriate tool to a torque of 0.25 Nm (see tooling on pages 35, 36 and 37). Push the bend relief (if used) onto the crimp ferrule.

Note: these terminating instructions apply to the following models:
M5 = FFS, FFV

Terminating of elbow plugs (90°) with cable collet (solder contact) **M6** and cable crimp (solder contact) **M7**

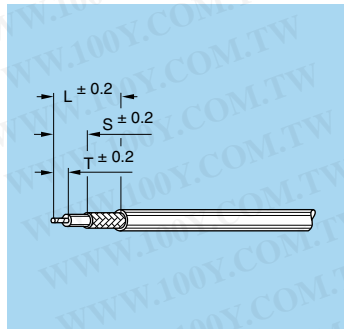
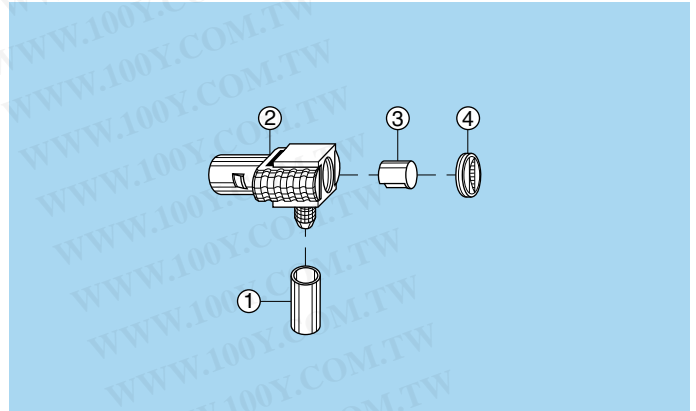
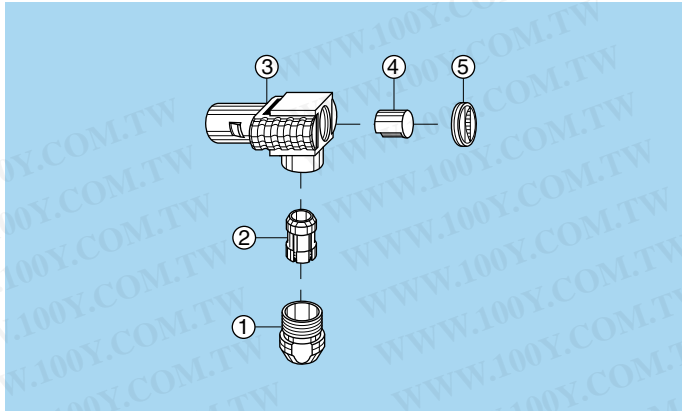

1. Cable preparation

First place the bend relief (if to be used) on the cable. Strip the cable according to dimensions below.

Cable group	M6		
	T	S	L
1-2-3-4-8	1	3.5	6.5

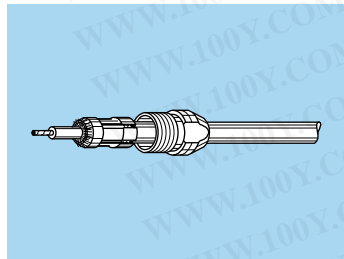

2. Cable terminating

2.1 Place the crimp ferrule ① and collet ② on the cable. Fold back the shield braid onto the conical part of the collet, and trim to outer edge of the collet.

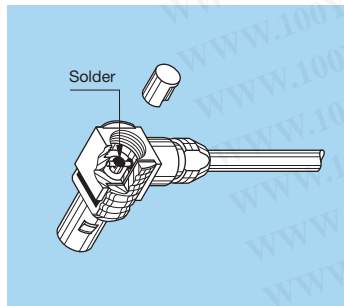

2.2 Slide the assembly into the connector shell ③ and tighten the collet nut ① using the appropriate tool to a torque of 0.25 Nm (see "Tooling" on page 35, 36 and 37). Check that the cable conductor rests in the contact slot, solder the conductor through the hole.

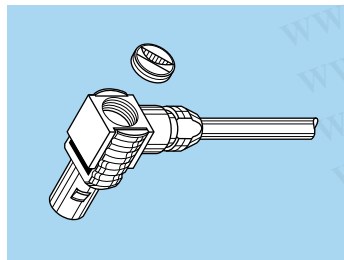

2.3 Place the insulating sleeve ④ over the soldered contact.

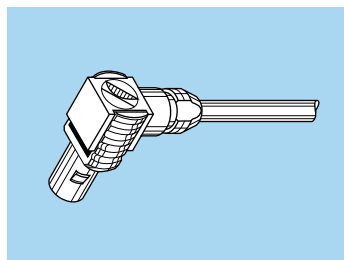

2.4 Close the access hole with the flat screw ⑤. Push the bend relief (if used) onto the collet nut ①.

Note: these terminating instructions apply to the following models:

M6 = FLA

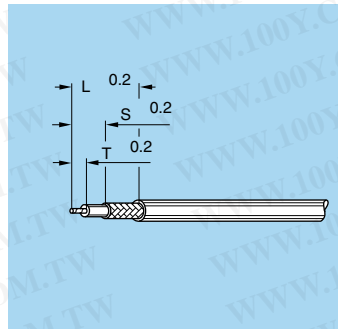

1. Cable preparation

First place the bend relief (if to be used) on the cable. Strip the cable according to dimensions below.

Cable group	M7		
	T	S	L
1-2-3-4-8	1	4.5	9
6-7	3	4.5	11

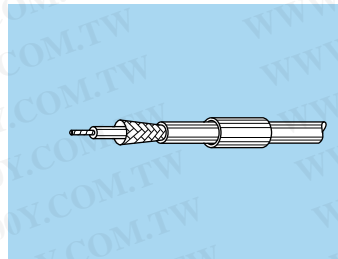

2. Cable terminating

2.1 Place the cable crimp ferrule ① on the cable and widen the braiding.

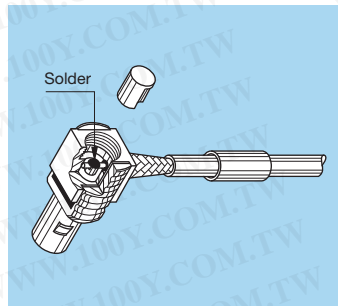

2.2 Slide the cable into the connector shell ②. Check that cable conductor rests in the contact slot, tin solder the conductor through the hole. Slide the crimp ferrule ① over the braiding until it reaches the connector shell ②. Crimp with the LEMO crimp tool using the hexagonal opening (see "Tooling" on page 37).

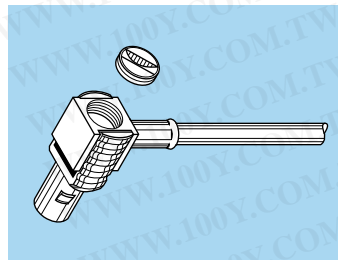

2.3 Place the insulating sleeve ③ over the soldered contact.

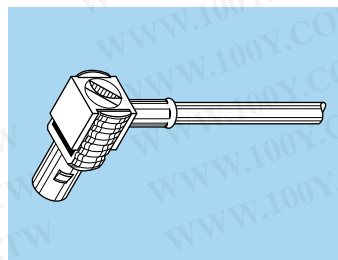

2.4 Close the connector hole with the flat screw ④. Push the bend relief (if used) onto the crimping tube ①.

Note: these terminating instructions apply to the following models:

M7 = FLS, FLV

勝特力材料 886-3-5753170
勝特力电子(上海) 86-21-34970699
勝特力电子(深圳) 86-755-83298787
[Http://www.100y.com.tw](http://www.100y.com.tw)

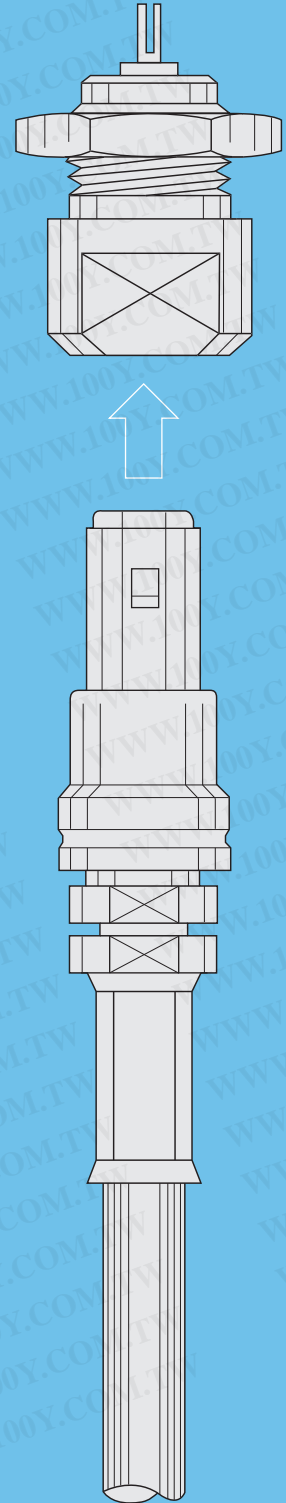

01 SERIES

01 Series

The plugs and sockets of the 01 series are amongst the smallest available 50 Ω coax connectors with a self-latching intermating capability. In spite of their small size and light weight, their technical characteristics remain excellent. Available in a wide range of housing configurations, they are especially useful when connecting onto printed circuit boards.

Metal housing models (page 46)

Fixed plug

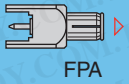

FPA

Straight plugs



FFS

Fixed sockets



ERA

Elbow socket

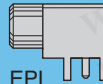

EPL

Fixed socket



PSS

Fixed coupler



RAD

Elbow plugs

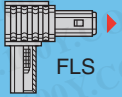

FLS

Straight plugs



FFH

Fixed sockets



ECP

Plug with resistor



FRT

Free socket



PCS

Free coupler

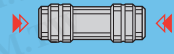

RMA

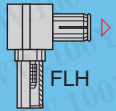

FLH

T-plug with two sockets

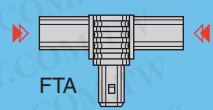

FTA

Adaptors (See page 50)

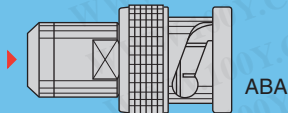

ABA

T-coupler

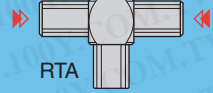

RTA

Threaded-latching models (See page 50)



FVS



EVP

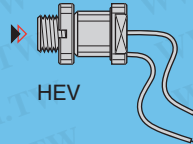

HEV

勝特力材料 886-3-5753170
 勝特力电子(上海) 86-21-34970699
 勝特力电子(深圳) 86-755-83298787
[Http://www.100y.com.tw](http://www.100y.com.tw)

Part Numbering System

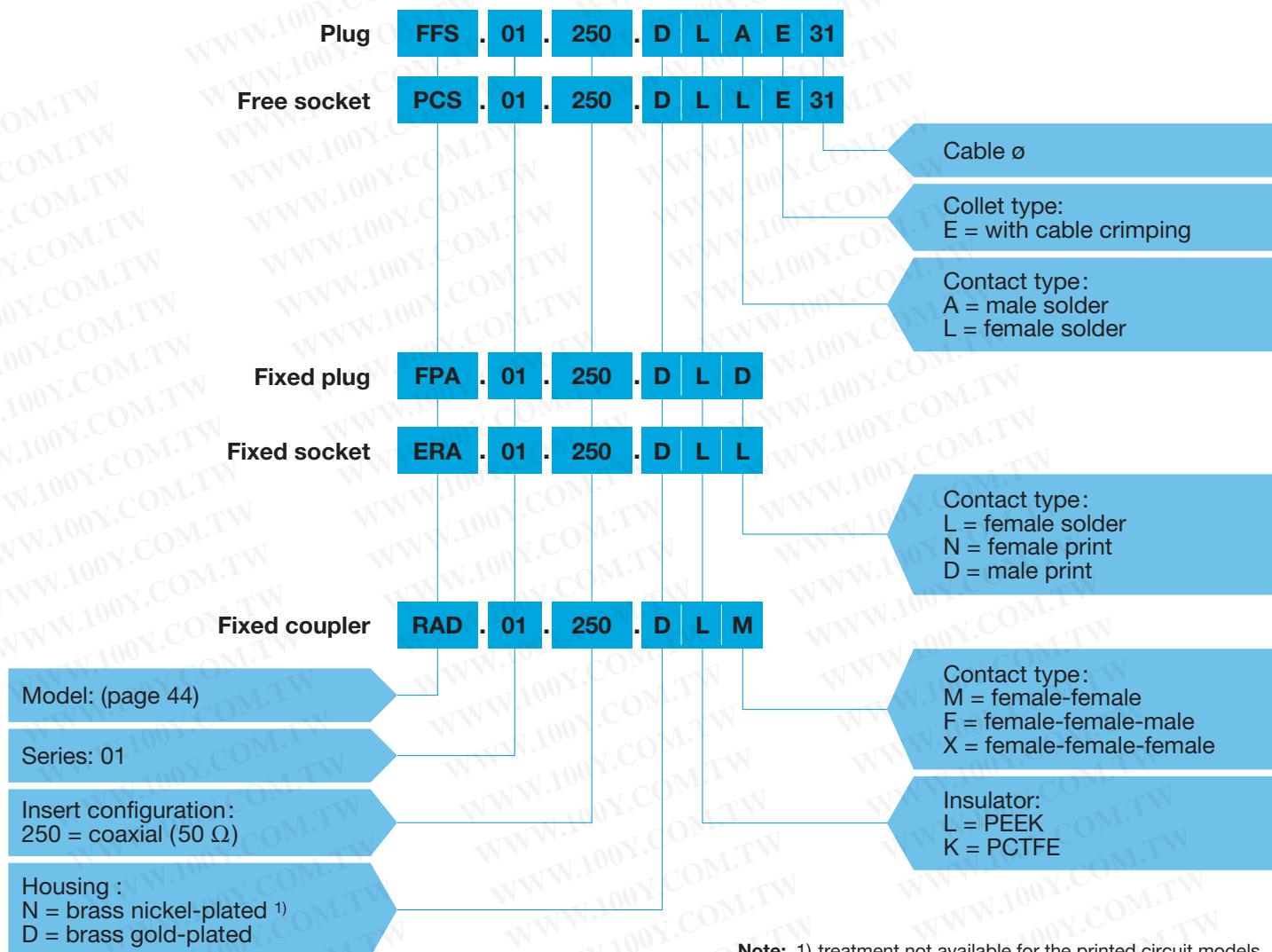

Part Number Example

FFS.01.250.DLAE31 = straight plug for cable crimping, 01 series, coaxial type 50 Ω, outer shell is gold-plated brass, PEEK insulator, male solder contact, type E crimp ferrule for cable group 2, 3 or 4.

勝特力材料 886-3-5753170
 勝特力电子(上海) 86-21-34970699
 勝特力电子(深圳) 86-755-83298787
[Http://www.100y.com.tw](http://www.100y.com.tw)

Part Section Showing Internal Components

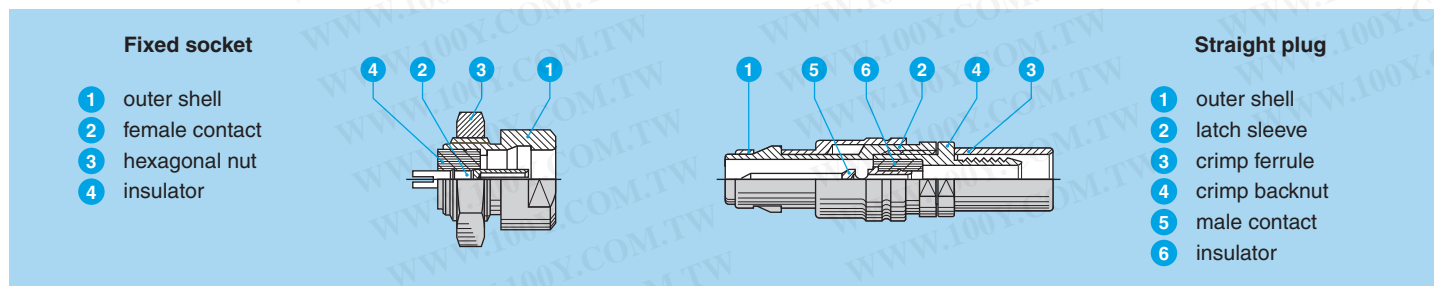

Metal housing models

Technical Characteristics

Mechanical and climatical

Characteristics	Value	Standard	Test
Contact retention force	> 60 N	IEC 69512-8	15a
Cable pull off force ¹⁾	> 100 N	IEC 69512-9	17c
Connector pull off force	> 110 N	IEC 69512-8	15f
Endurance	> 1000 cycles	IEC 69512-5	9a
Operating temperature	- 55°C + 230°C		

Note: ¹⁾ Depending on cable design
1N = 0.102 kg

Electrical

Characteristics	Value	Standard	Method
Impedance	50 Ω	-	
Operating voltage (50 Hz)	0.3 kV rms	-	
Test voltage (50 Hz)	1.0 kV rms	IEC 60512-2	4a
Rated current	4 A	IEC 60512-3	5a
Contact resistance	< 6 mΩ	IEC 60512-2	2a
Screen resistance	< 3.5 mΩ		
Insulating resistance	> 10 ¹² Ω	IEC 60512-2	3a
VSWR	see chart N°1 beside		

Voltage Standing Wave Ratio

The VSWR (Voltage Standing Wave Ratio) is the value representing the power reflected in a connection. In most cases, the working frequency range is where VSWR is ≤ 1.25.

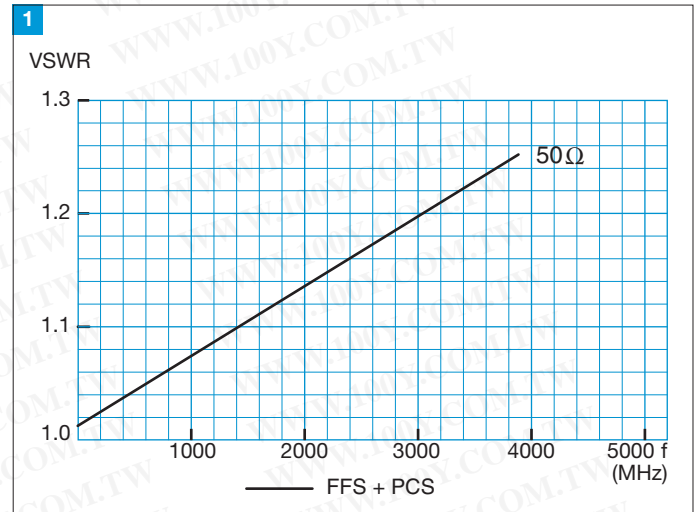

Note: VSWR measured with a RG-174 A/U cable. According to IEC 60169-1-1 standard

勝特力材料 886-3-5753170
 勝特力电子(上海) 86-21-34970699
 勝特力电子(深圳) 86-755-83298787
[Http://www.100y.com.tw](http://www.100y.com.tw)

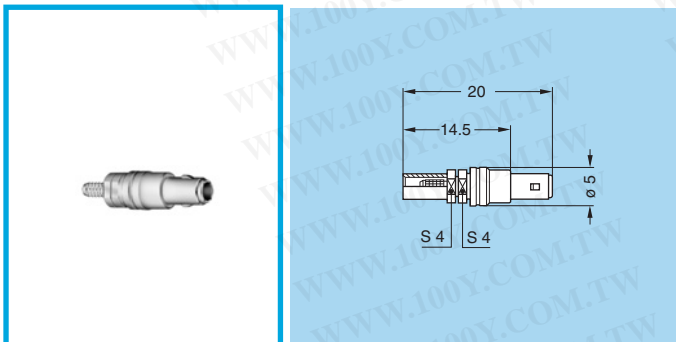

FFS Straight plug for cable crimping

Part number	Cable group	Cond. Ø max	Dielectric Ø max	Sheath Ø max
FFS.01.250.DLAE24	1	0.55	0.95	2.35
FFS.01.250.DLAE31	2-3-4	0.55	1.65	3.0

M1 Cable assembly (page 53)

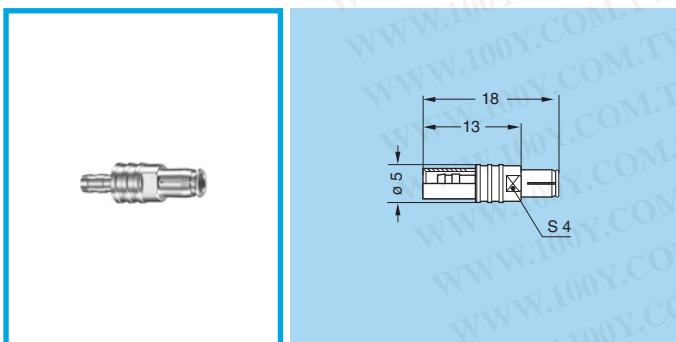

FFH Straight plug, non-latching for cable crimping

Part number	Cable group	Cond. Ø max	Dielectric Ø max	Sheath Ø max
FFH.01.250.DLAE31	2-3-4	0.55	1.65	3.0

M1 Cable assembly (page 53)

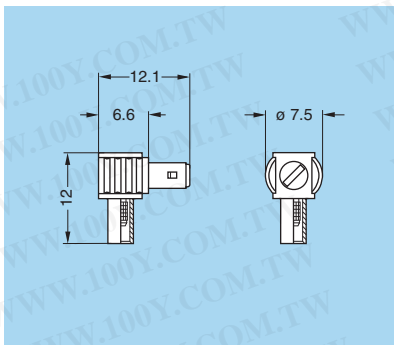

FLS Elbow plug (90°) for cable crimping

Part number	Cable group	Cond. Ø max	Dielectric Ø max	Sheath Ø max
FLS.01.250.●LAE24	1	0.5	0.95	2.35
FLS.01.250.●LAE31	2-3-4	0.5	1.65	3.0

M2 Cable assembly (page 53)

● = material of shell D or N

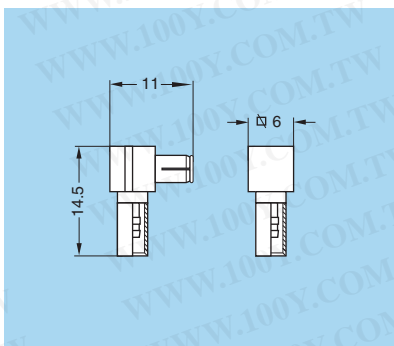

FLH Elbow plug (90°) non-latching, for cable crimping

Part number	Cable group	Cond. Ø maxi	Dielectric Ø maxi	Sheath Ø maxi
FLH.01.250.●LAE31	2-3-4	0.4	1.65	3.0

M3 Cable assembly, crimp contact (page 53)

● = material of shell D or N

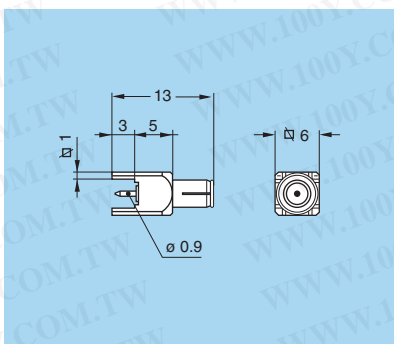

FPA Straight plug, non-latching, for printed circuit

Part number	Weight (g)
FPA.01.250.DLD	1.5

P4 PCB drilling pattern (page 53)

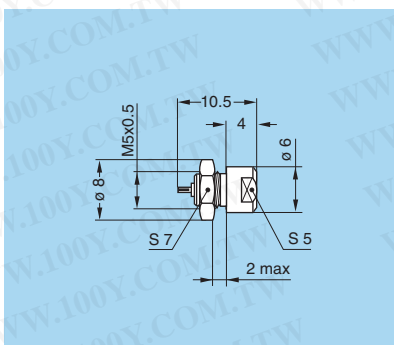

ERA Fixed socket, nut fixing

Part number	Weight (g)
ERA.01.250.●LL	1.3

P1 Panel cut-out (page 53)

● = material of shell D or N

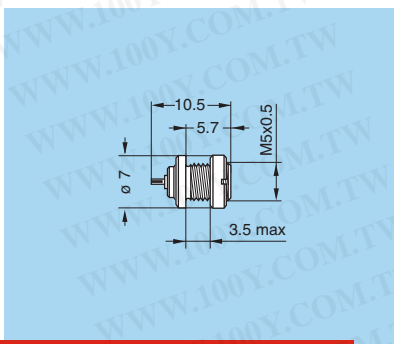

ECP Fixed socket, nut fixing (back panel mounting)

Part number	Weight (g)
ECP.01.250.●LL	1.1

P1 Panel cut-out (page 53)

● = material of shell D or N

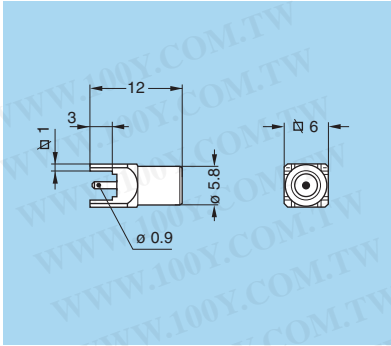

EPA Straight socket for printed circuit

Part number	Weight (g)
EPA.01.250.DLN	1.6

P4 PCB drilling pattern (page 53)

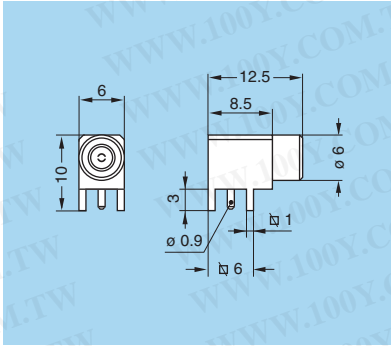

EPL Elbow socket (90°) for printed circuit

Part number	Weight (g)
EPL.01.250.DLN	3.2

P4 PCB drilling pattern (page 53)

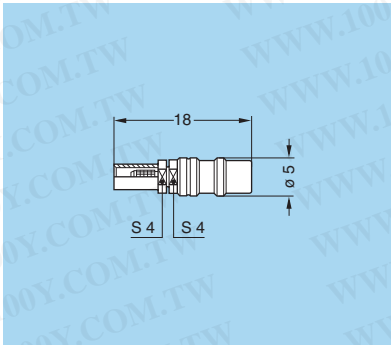

PCS Free socket for cable crimping

Part number	Cable group	Cond. Ø max	Dielectric Ø max	Sheath Ø max
PCS.01.250.DLLE24	1	0.55	0.95	2.35
PCS.01.250.DLLE31	2-3-4	0.55	1.65	3.0

M1 Cable assembly (page 53)

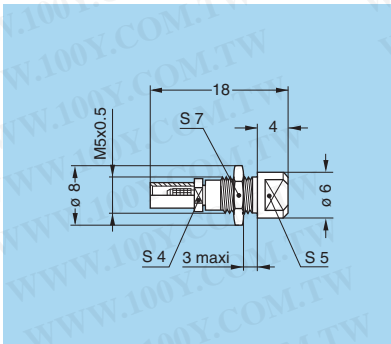

PSS Fixed socket, nut fixing, for cable crimping

Part number	Cable group	Cond. Ø max	Dielectric Ø max	Sheath Ø max
PSS.01.250.DLLE24	1	0.55	0.95	2.35
PSS.01.250.DLLE31	2-3-4	0.55	1.65	3.0

M1 Cable assembly (page 53)

P1 Panel cut-out (page 53)

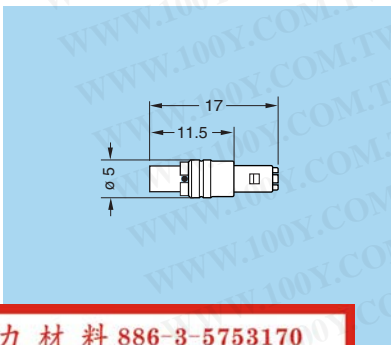

FRT Straight plug with resistor

Part number	Resistor	Weight (g)
FRT.01.250.DLA50	50 Ω 0.6W	1.0

Note: Non standard, on request only

勝特力材料 886-3-5753170
 勝特力电子(上海) 86-21-34970699
 勝特力电子(深圳) 86-755-83298787
[Http://www.100y.com.tw](http://www.100y.com.tw)

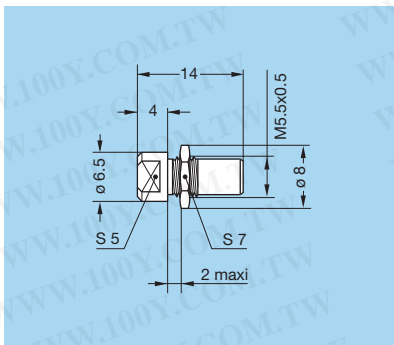

RAD Fixed coupler, nut fixing

Part number	Weight (g)
RAD.01.250.DLM	1.8

P2 Panel cut-out (page 53)

Note: Non standard, on request only

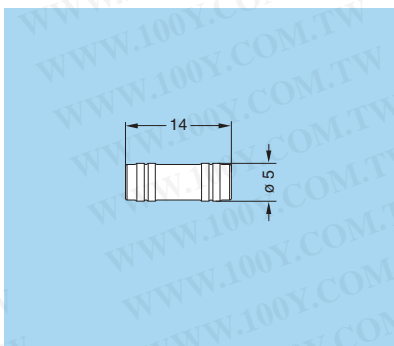

RMA Free coupler

Part number	Weight (g)
RMA.01.250.DLM	1.1

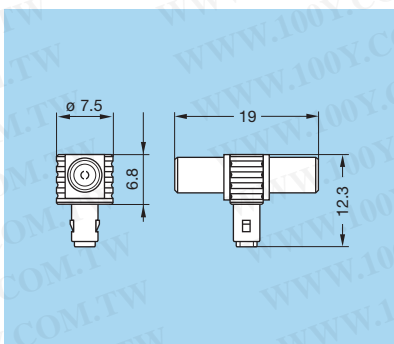

FTA T-plug with two sockets in line

Part number	Weight (g)
FTA.01.250.DLF	2.6

Note: Non standard, on request only

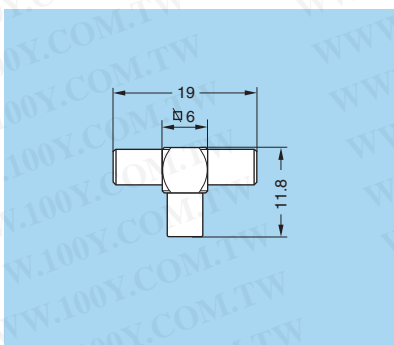

RTA T-coupler with three sockets

Part number	Weight (g)
RTA.01.250.DLX	2.5

勝特力材料 886-3-5753170
 勝特力电子(上海) 86-21-34970699
 勝特力电子(深圳) 86-755-83298787
[Http://www.100y.com.tw](http://www.100y.com.tw)

Threaded-latching models

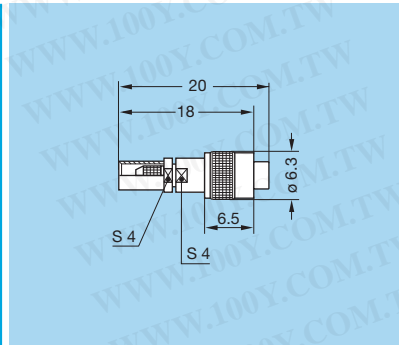

FVS Straight plug, threaded latching for cable crimping

Part number	Cable group	Cond. Ø max	Dielectric Ø max	Sheath Ø max
FVS.01.250.NKAE31	2-3-4	0.55	1.65	3.0

M1 Cable assembly (page 53)

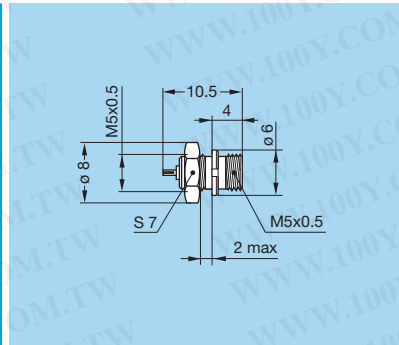

EVP Fixed socket, nut fixing for threaded latching plug

Part number	Weight (g)
EVP.01.250.NKL	1.2

P1 Panel cut-out (page 53)

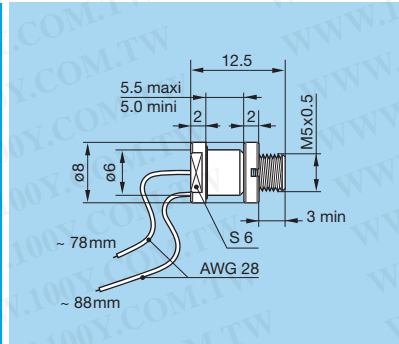

HEV Fixed socket, round nut fixing for threaded latching plug, watertight (back panel mounting)

Part number	Weight (g)
HEV.01.250.NKL	2.3

P3 Panel cut-out (page 53)

Note: this model is fitted with 2 wires AWG28 soldered before potting

Adaptors

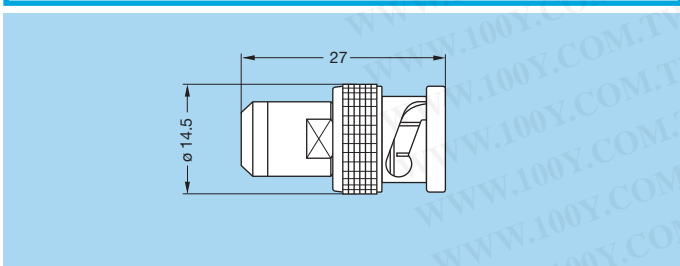
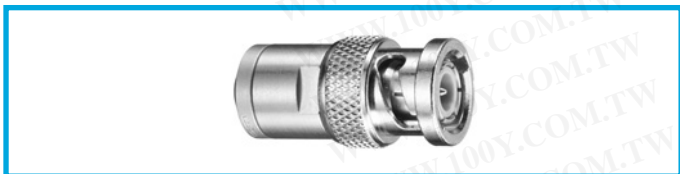

ABA Adaptor from LEMO socket to BNC plug

Part number	Weight (g)
ABA.01.250.NLL	17.5

勝特力材料 886-3-5753170
 勝特力电子(上海) 86-21-34970699
 勝特力电子(深圳) 86-755-83298787
[Http://www.100y.com.tw](http://www.100y.com.tw)

Spare parts

FFS Crimp ferrule

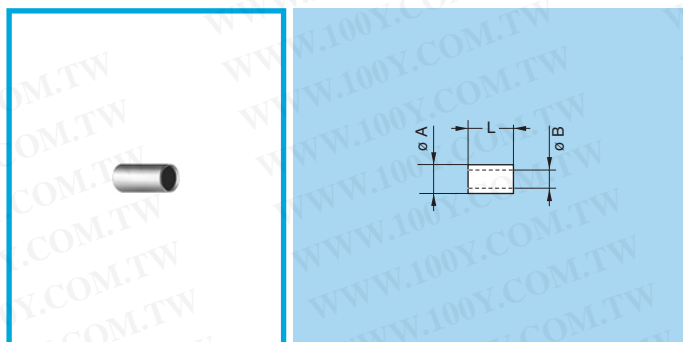

Part number	Cable group	Dim.		
		ØA	ØB	L
FFS.01.160.DA	1	3.1	2.4	6
FFS.01.161.DA	2-3-4	3.8	3.05	6
FFH.01.161.D ¹⁾	2-3-4	3.8	3.1	7

Note: 1) for models FFH and FLH
Sockets and plugs to be crimped are always supplied with a crimp ferrule. To order this accessory separately, use the above part numbers.

- Material: Copper (UNS C 18700) nickel (3µm) + gold plated (0.5µm)

GEA Hexagonal nut

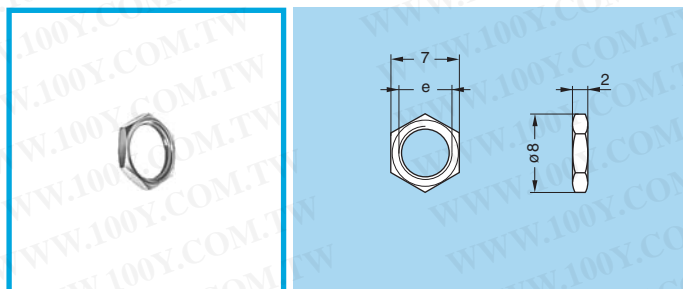

Part number	e (mm)	Models	Weight (g)
GEA.01.240.LN	M5x0.5	ERA, EVP, PSS	0.39
GEA.01.241.LN	M5.5x0.5	RAD	0.31

Note: to order this accessory separately, use the above part number.

- Material: Brass (UNS C 38500) nickel-plated (3 µm)

GEB Round nut

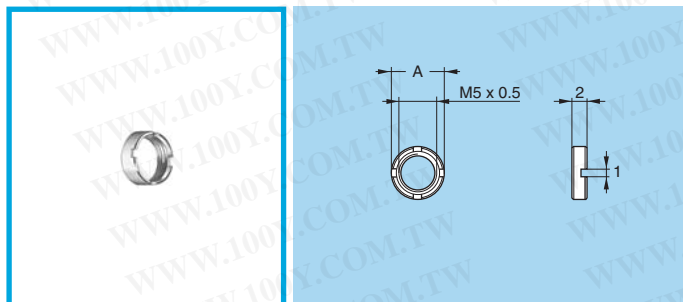

Part number	A (mm)	Models	Slot nb.	Weight (g)
GEB.01.240.LN	Ø 7	ECP	2	0.30
GEB.01.244.LN	Ø 8	HEV	4	0.50

Note: to order this accessory separately, use the above part number.

- Material: Brass (UNS C 38500) nickel-plated (3 µm)

勝特力材料 886-3-5753170
 勝特力电子(上海) 86-21-34970699
 勝特力电子(深圳) 86-755-83298787
[Http://www.100y.com.tw](http://www.100y.com.tw)

Tooling

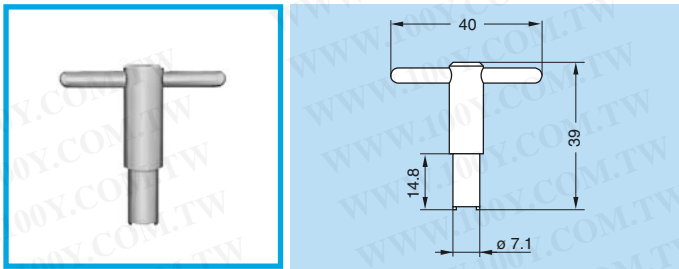

DCB Spanner for round nut (for ECP and HEV model)

Part number	Part number of the nut
DCB.91.097.0TN	GEB.01.240.LN / GEB.01.244.LN

- Material: Blackened steel



DPE Crimping tool with die

Part number	Cable group	Crimp collet ref.
DPE.99.000.00	Crimping tool with no die	
DPE.99.003.1K ¹⁾	1	E24
DPE.99.003.8K ²⁾	2-3-4	E31

- Note:** 1) Hex cavity of DPE.99.123.1K can also be used
2) Hex cavity of DPE.99.123.8K can also be used

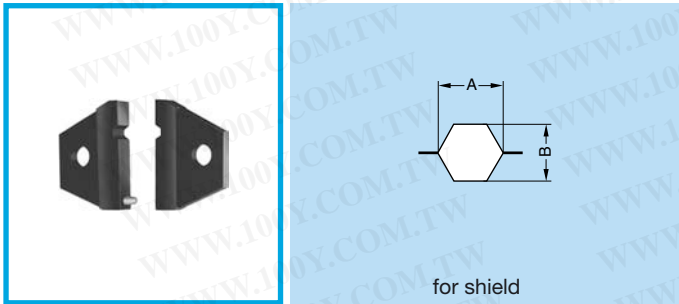

DPN Dies

Part number	Cable group	Die dimension For shield	
		A	B
DPN.99.003.1K	1	3.10	2.70
DPN.99.003.8K	2-3-4	3.80	3.30

- Dies material: Blackened steel

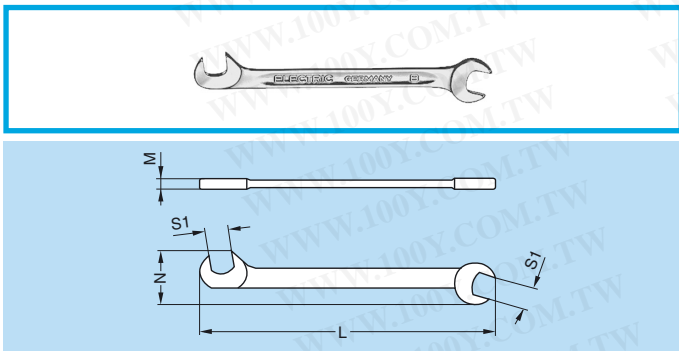

DCP Flat spanner

Part number	Dimensions (mm)			
	L	M	N	S1
DCP.99.040.TC	70	0.95	10.5	4.0
DCP.99.045.TC	70	2.00	10.5	4.5
DCP.99.050.TC	78	2.00	12.6	5.0
DCP.99.055.TC	78	2.00	12.6	5.5
DCP.99.060.TC	78	2.00	12.6	6.0

- Material: Chrome-plated steel

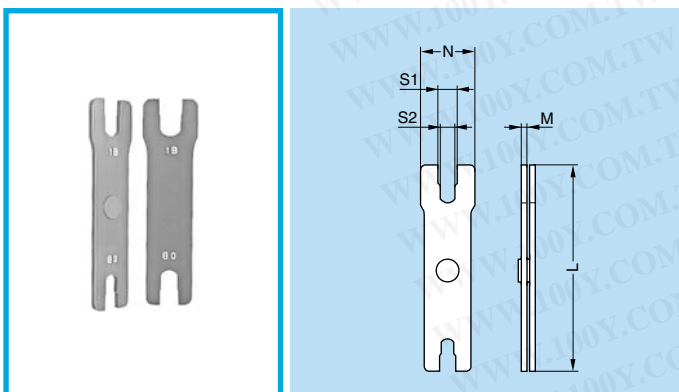

DCP Set of flat spanners

Part number	Dimensions				
	L	M	N	S1	S2
DCP.91.001.TN	95	2.5	21	8.1	7.1

- Material: Blackened steel

Panel cut-outs

Panel cut-out

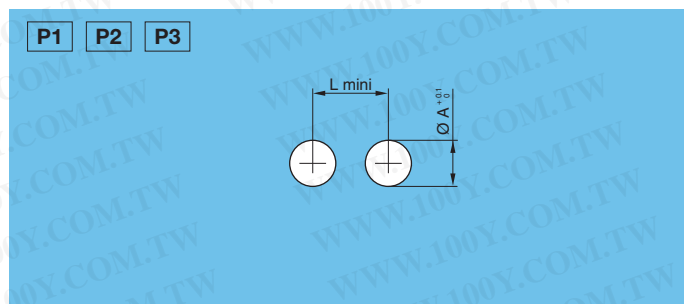

Cut-out	Model	Dimensions	
		A	L
P1	ERA-ECP-EVP-PSS	5.1	9.5
P2	RAD	5.6	10.0
P3	HEV	6.1	10.0

Recommended mounting nut torque: 1.5 Nm.

PCB drilling pattern

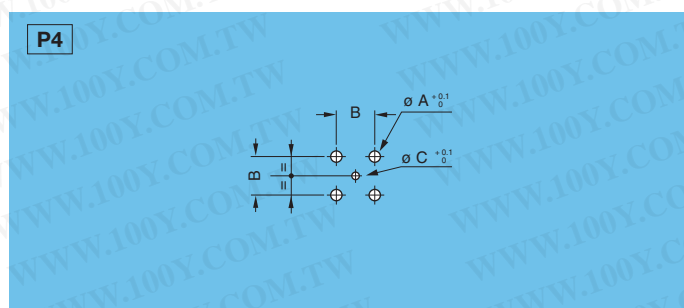

Drill	Model	Dimensions		
		A	B	C
P4	EPA, FPA, EPL	1.5	5.08	1.0

Cable assembly

Terminating of plugs and straight sockets with cable crimping (solder contact) M•

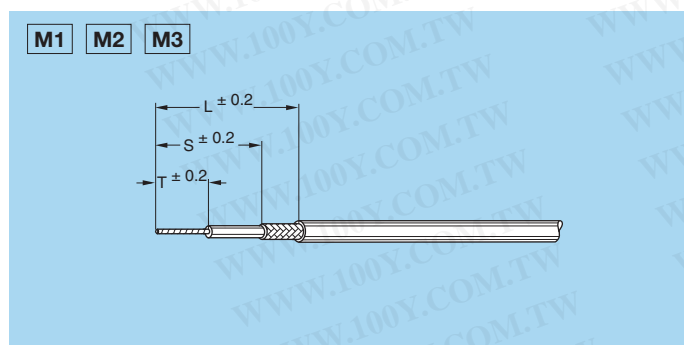

The cable assembly of the 01.250 requires specific stripping dimensions. See below. However the procedure is similar to the 00.250 series. See pages 41 and 42.

Cable assembly	Model	T	S	L	Instruction of the 00 series to use as a reference
M1	FFH-FFS-FVS PCS-PSS	3.5	6	10	M5 (page 41)
M2	FLS	1.2	4	8.5	M7 (page 42)
M3	FLM	1.2	4	10	M7 (page 42)

勝特力材料 886-3-5753170
 勝特力电子(上海) 86-21-34970699
 勝特力电子(深圳) 86-755-83298787
[Http://www.100y.com.tw](http://www.100y.com.tw)

勝特力材料 886-3-5753170
勝特力电子(上海) 86-21-34970699
勝特力电子(深圳) 86-755-83298787
[Http://www.100y.com.tw](http://www.100y.com.tw)

Technical Characteristics

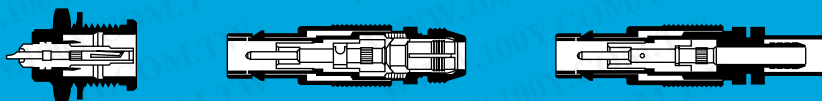

Outer Shell

Brass

LEMO series 00 & 01 connectors have a brass outer shell as standard, and this is suitable for most general purpose applications, including civilian and military.

The brass outer shells have a nickel-plated surface which ensures very good protection against most environments. Alternative protective coatings available are:

- Nickel-chrome offering higher protection against salt air and most corrosive agents
- Nickel-gold
- Nickel-black chrome. After the black chrome treatment, the part is coated with a protective film.

The shell surface is protected by anodizing which is available in six colors: blue, yellow, black, red, green, and natural.

Plastic Materials

A PEEK outer shell is available which offers excellent insulating properties and is mostly used in the medical industry. This material is suitable for gas or steam sterilization.

Other Metallic Components

In general, other components are manufactured from brass. However, bronze is used where good elasticity is required (for example: earthing crown).

These parts are nickel or nickel-gold plated depending on the utilization.

Materials and Treatment

Component	Material (Standard)	Surface Treatment (µm)										
		Nickel		Chrome			Gold			Black Chrome		
		Cu	Ni	Cu	Ni	Cr	Cu	Ni	Au	Cu	Ni	Cr
Outer shell, collet nut, conical nut or notched nut	Brass (UNS C 38500)	0.5	3	0.5	3	0.3	0.5	3	0.5	-	1	2
	Aluminium alloy	anodized										
	PEEK	beige colored										
Earthing crown	Cu-Be (UNS C 17300)	0.5	3	-	-	-	0.5	3	1.5	-	-	-
Latch sleeve	Special Brass	0.5	3	-	-	-	0.5	3	1.5	-	-	-
Crimp ferrule	Copper (UNS C 18700)	0.5	3	-	-	-	0.5	3	1.5	-	-	-
Locking washer	Bronze (UNS C 52100)	0.5	3	-	-	-	0.5	3	0.5	-	-	-
Hexagonal nut	Brass (UNS C 38500)	0.5	3	-	-	-	0.5	3	0.5	-	-	-
Other metallic components	Brass (UNS C 38500)	0.5	3	-	-	-	0.5	3	0.5	-	-	-
O-ring and gaskets	Silicone or FPM	without treatment										
Sealing resin	Epoxy	-										

Notes: The surface treatment standards are as follows:

- nickel FS QQ-N-290A, or MIL-C-26074C
- chrome FS QQ-C-320B
- gold ISO 4523
- black chrome MIL-C-14538C with a minimum of 10 µm lacquer protection

Electrical Characteristics

Shell electrical continuity (measured according to IEC 60512-2 test 2f)

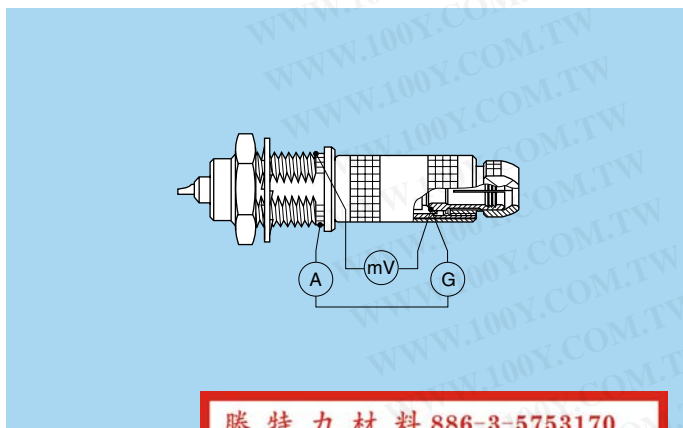

- R₁** Values with earthing crown and latch sleeve or inner-sleeve nickel plated.
- R₂** Values with gold-plated earthing crown and nickel plated latch sleeve or inner-sleeve.
- R₃** Values with earthing crown and gold-plated latch sleeve or inner-sleeve.

Serie 00			Serie 01		
R ₁ (mΩ)	R ₂ (mΩ)	R ₃ (mΩ)	R ₁ (mΩ)	R ₂ (mΩ)	R ₃ (mΩ)
3.5	2.8	2.0	N.A	2.3	1.5

Testing current: 1A
 A = Ammeter
 mV = Millivoltmeter
 G = Generator

勝特力材料 886-3-5753170
 勝特力电子(上海) 86-21-34970699
 勝特力电子(深圳) 86-755-83298787
 Http://www.100y.com.tw

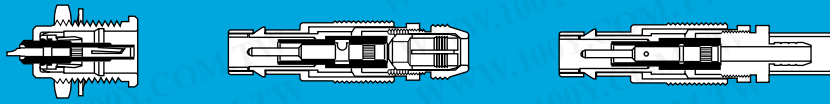

Insulator

Technical Description

LEMO uses virgin quality PTFE for the insulator material of coaxial connectors, which guarantees excellent insulating properties.

LEMO also proposes PEEK (Polyether Etherketone). Its higher mechanical strength and excellent radiation resistance make it ideal for most applications.

Radiation resistance

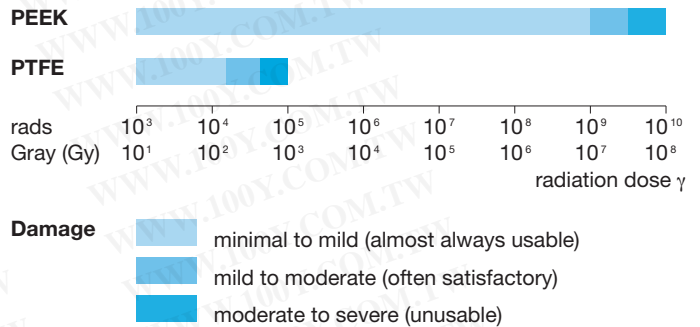

Technical Characteristics

Property	Test method	Unit	PEEK	PTFE
Dielectric strength	ASTM D 149 / IEC 60243	kV/mm	19 - 25	17.2 - 24
Volume resistivity at 50% HR and 23°C	ASTM D 257 / IEC 60093	$\Omega \cdot \text{cm}$	10 ¹⁶	10 ¹⁸
Surface resistivity	ASTM D 257 / IEC 60093	Ω	10 ¹⁵	10 ¹⁷
Thermal conductivity	ASTM C 177	W/K · m	0.25	0.23
Comparative tracking index	IEC 60112	V	CTI 150	CTI 500
Dielectric constant (10 ⁶ Hz)	ASTM D 150 / IEC 60250	-	3.2 - 3.5	2 - 2.1
Dissipation factor (10 ⁶ Hz)	ASTM D 150 / IEC 60250	-	< 0.005	< 0.0003
Maximum continuous service temperature	-	°C	250	260
Minimum continuous service temperature	-	°C	-53	-200
Water absorption in 24h at 23°C	ASTM D 570 / ISO R624	%	< 0.3	< 0.01
Radiation resistance	-	Gy	10 ⁷	2 · 10 ²
Flammability rating	UL 94 / UL 94	-	V 0	V 0

Note: the technical data contained in this chapter gives a general information about plastic materials used by LEMO as electrical insulator materials. LEMO reserves the right to propose new material which would have higher technical characteristics and to withdraw any material contained in this publication or others from LEMO and its subsidiary companies. LEMO only uses granulated, powdered plastic materials or bars from specialized suppliers. LEMO is not responsible, in any case, for these materials.

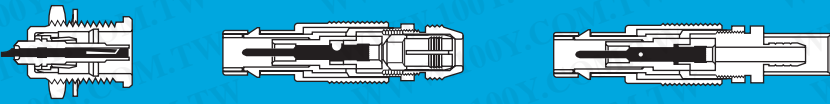

Electrical Contact

Technical Description

The secure, reliable electromechanical connection achieved with LEMO female contacts is mainly due to two important design features:

1. *Prod proof entry* which ensures perfect concentric mating even with well used and/or carelessly handled connectors.
2. *The pressure spring* that maintains a constant, even force on the male contact when mated. The leading edge of the spring is chamfered to slide smoothly on the male contact, preserving the gold-plated surface treatment and preventing undue wear.

Contact Material

LEMO female electrical contacts are made from bronze (UNS C 54400). Bronze is chosen because of its high modulus of elasticity, its excellent electrical conductivity and a high mechanical strength.

LEMO male solder and print contacts are made from brass (UNS C 38500). Male crimp contacts are made from brass (UNS C 34500) which is ideal for crimping onto the electrical conductor.

Conductor retention method

Both male and female contacts are available in crimp, solder or print versions.

Insulation resistance between the contacts and contact/shell

(measured according to IEC 60512-2 test 3a)

Insulating material	Multipole	Unipole
	PEEK	PTFE
new	> 10 ¹² Ω	> 10 ¹² Ω
after humidity test ¹⁾	> 10 ¹⁰ Ω	> 10 ¹⁰ Ω

Note: ¹⁾ 21 days at 95% RH according to IEC 60068-2-3.

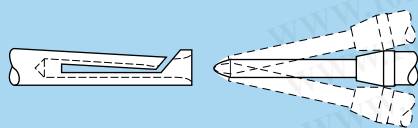

Materials and Treatments

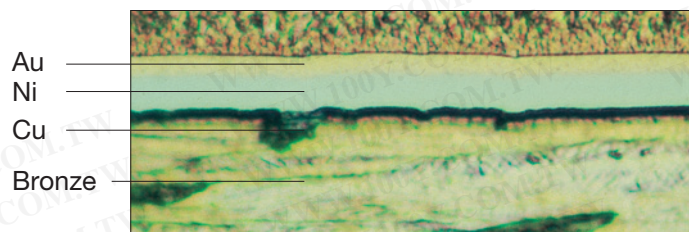

Notes: the standard surface treatments are as follows:

- Nickel FS QQ-N-290A or MIL-C-26074C
- Gold ISO 4523

Type	Material (Standard)	Surface treatment (μm)		
		Cu	Ni	Au ¹⁾
Male solder	Brass (UNS C 38500)	0.5	3	1.0
Male crimp	Brass (UNS C 34500)			
Male print	Brass (UNS C 38500)			
Female solder	Bronze (UNS C 54400)	0.5	3	1.5
Female crimp				
Female print				

¹⁾ minimum value

Solder Contacts

The conductor bucket of these contacts is machined at an angle to form a cup into which the solder can flow. Design is compatible with the use of lead-free solder.

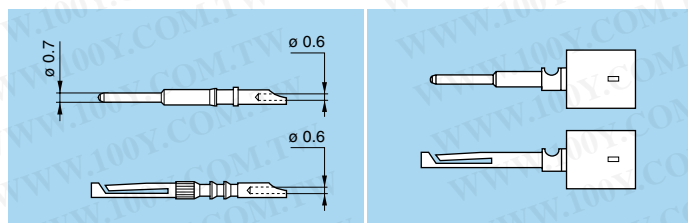

Features of the LEMO crimp contacts:

- Quick and simple assembly
- Insulator is not heated during contact to conductor assembly
- High temperature applications possible
- Increased conductor retention force

Print contacts

Print contacts are available in certain connectors versions, mostly for the straight or elbow sockets models. Connection is made on flexible or rigid printed circuits by soldering

Crimp Contacts

The square form crimp method is used (MIL-C-22520F, type 2) (photo 1).

The crimp method requires a controlled compression to obtain a symmetrical deformation of the conductor strand and of the contact material. The radial hole in the side of the contact enables correct positioning of the conductor within the contact to be verified. A good crimping is characterized by a small conductor section reduction and by the quite closed free spaces.

The LEMO crimp contacts are factory annealed to relieve internal stresses, and reduce the risk of the material work hardening during the crimping process. During this process, an induction heating machine designed by LEMO's Research and Development Department is used (photo 2).

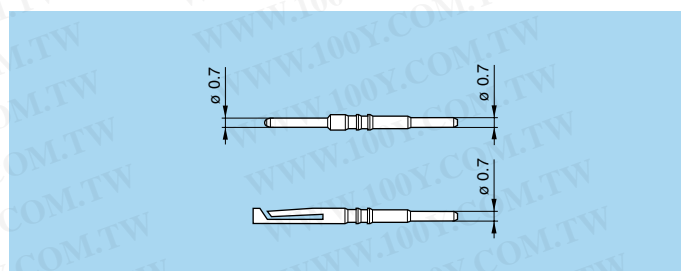
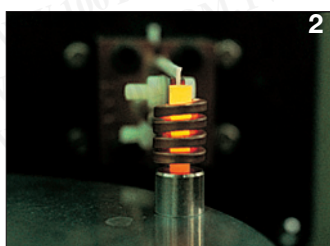
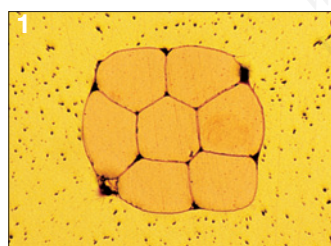
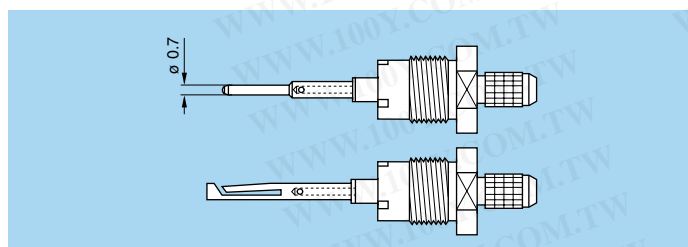

Contact Resistance in Relation to Numbers of Mating Cycles (measured according to IEC 605/2-2 test 2a)

Contact resistance (m Ω)		
1000 cycles	3000 cycles	5000 cycles
5.6	5.7	6.1

Maximum values measured after the mating cycles and the salt spray test according to IEC 60512-6 test 11f.

Thickness comparison between the outside and the inside of female contacts

male (μm)	Gold thickness female	
	outside (μm)	inside (%)
1.0	1.5	70

A = inspection point

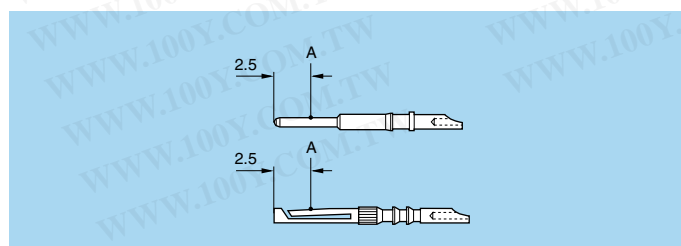

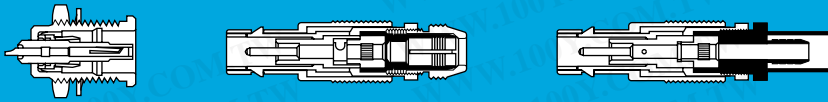

Cable Fixing

Cable fixing onto LEMO connectors is determined by the connector model. This is achieved either with a cable collet system or with hexagonal crimping (MIL-C-22520F, type 2).

The collet system cable fixing is made without any special tooling. The crimping method guarantees a good electrical continuity of the shield which improves greatly the shielding efficiency of the cable/connector link.

Material and Treatment

Component	Material (Standard)	Surface Treatment (µm)	
		Cu	Ni
Earthing sleeve	Brass (UNS C 38500)	0.5	3
Collet	Brass (UNS C 38500)	0.5	3
Crimp ferrule	Copper (UNS C 18700)	0.5	3
Collet nut	Brass (UNS C 38500)	0.5	3

Note: collet nut tightening torque: maximum 0.25 Nm (1N = 0.102 kg)

Technical tables

VSWR effect on transmitted power

VSWR	VSWR (dB)	Return loss (dB)	Transmiss. loss (dB)	Reflected voltage coefficient	Transmit. power (%)	Reflected power (%)
1.00	0		0.000	0.00	100.0	0.0
1.01	0.1	46.1	0.000	0.00	100.0	0.0
1.02	0.2	40.1	0.000	0.01	100.0	0.0
1.03	0.3	36.6	0.001	0.01	100.0	0.0
1.04	0.3	34.2	0.003	0.03	100.0	0.0
1.05	0.4	32.3	0.003	0.02	99.9	0.1
1.06	0.5	30.7	0.004	0.03	99.9	0.1
1.07	0.6	29.4	0.005	0.03	99.9	0.1
1.08	0.7	28.3	0.006	0.04	99.9	0.1
1.09	0.7	27.3	0.008	0.04	99.8	0.2
1.10	0.8	26.4	0.010	0.05	99.8	0.2
1.11	0.9	25.7	0.012	0.05	99.7	0.3
1.12	1.0	24.9	0.014	0.06	99.7	0.3

VSWR	VSWR (dB)	Return loss (dB)	Transmiss. loss (dB)	Reflected voltage coefficient	Transmit. power (%)	Reflected power (%)
1.13	1.1	24.3	0.016	0.06	99.6	0.4
1.14	1.1	23.7	0.019	0.07	99.6	0.4
1.15	1.2	23.1	0.021	0.07	99.5	0.5
1.16	1.3	22.6	0.024	0.07	99.5	0.5
1.17	1.4	22.1	0.027	0.08	99.4	0.6
1.18	1.4	21.7	0.030	0.08	99.3	0.7
1.19	1.5	21.2	0.033	0.09	99.2	0.8
1.20	1.6	20.8	0.036	0.09	99.2	0.8
1.21	1.7	20.4	0.039	0.10	99.1	0.9
1.22	1.7	20.1	0.043	0.10	99.0	1.0
1.23	1.8	19.7	0.046	0.10	98.9	1.1
1.24	1.9	19.4	0.050	0.11	98.9	1.1
1.25	1.9	19.1	0.054	0.11	98.8	1.2

勝特力材料 886-3-5753170
 勝特力电子(上海) 86-21-34970699
 勝特力电子(深圳) 86-755-83298787
[Http://www.100y.com.tw](http://www.100y.com.tw)

Product safety notice

PLEASE READ AND FOLLOW ALL INSTRUCTIONS CAREFULLY AND CONSULT ALL RELEVANT NATIONAL AND INTERNATIONAL SAFETY REGULATIONS FOR YOUR APPLICATION. IMPROPER HANDLING, CABLE ASSEMBLY, OR WRONG USE OF CONNECTORS CAN RESULT IN HAZARDOUS SITUATIONS.

1. SHOCK AND FIRE HAZARD

Incorrect wiring, the use of damaged components, presence of foreign objects (such as metal debris), and / or residue (such as cleaning fluids), can result in short circuits, overheating, and / or risk of electric shock.

Mated components should never be disconnected while live as this may result in an exposed electric arc and local overheating, resulting in possible damage to components.

2. HANDLING

Connectors and their components should be visually inspected for damage prior to installation and assembly. Suspect components should be rejected or returned to the factory for verification.

Connector assembly and installation should only be carried out by properly trained personnel. Proper tools must be used during installation and / or assembly in order to obtain safe and reliable performance.

3. USE

Connectors with exposed contacts should never be live (or on the current supply side of a circuit). Under general conditions voltages above 30 VAC and 42 VDC are considered hazardous and proper measures should be taken to eliminate all risk of transmission of such voltages to any exposed metal part of the connector.

4. TEST AND OPERATING VOLTAGES

The maximum admissible operating voltage depends upon the national or international standards in force for the application in question. Air and creepage distances impact the operating voltage; reference values are indicated in the catalog however these may be influenced by PC board design and / or wiring harnesses.

The test voltage indicated in the catalog is 75% of the mean breakdown voltage; the test is applied at 500 V/s and the test duration is 1 minute.

5. CE MARKING

CE Marking is applied to a complete product or device, and implies that the device complies with one or several European safety directives.

CE Marking can not be applied to electromechanical components such as connectors.

6. PRODUCT IMPROVEMENTS

The LEMO Group reserves the right to modify and improve to our products or specifications without providing prior notification.

勝特力材料 886-3-5753170
勝特力电子(上海) 86-21-34970699
勝特力电子(深圳) 86-755-83298787
[Http://www.100y.com.tw](http://www.100y.com.tw)

WWW.100Y.COM.TW

勝特力材料 886-3-5753170
勝特力电子(上海) 86-21-34970699
勝特力电子(深圳) 86-755-83298787
[Http://www.100y.com.tw](http://www.100y.com.tw)

LEMO complete product range

	B	S	K	E	F	00	01	0A	3T	4A	4M	3K.93C	1D	Y	05	5G	2G	2C	L	H	M	R	N	03	V	W	F	P	D	K/S	01	DIN	
Unipole																																	
Multipole					•	•																											
Coaxial 50 Ω																																	
Coaxial 75 Ω																																	
Multi Coaxial																																	
Mixed Coax + LV																																	
Triaxial 50 Ω																																	
Triaxial 75 Ω																																	
Mixed Triax + LV																																	
Quadrax																																	
High Voltage																																	
Multi High Voltage																																	
Mixed HV + LV																																	
Fibre Optic																																	
Multi Fibre Optic																																	
Mixed FO + LV																																	
Thermocouple																																	
Fluidic																																	
Multi Fluidic																																	
Mixed Fluidic + LV																																	

Most frequently used in darker colour

• included in this catalogue

B Series Keyed	S Series	K Series Keyed	E Series	F Series Keyed	00 Series	01 Series
0A Series	3T Series	4A Series	4M Series Keyed	3K.93C Series Keyed	1D Series	Y Series
05 Series	5G Series Keyed	2G Series Keyed	2C Series	L Series Keyed	H Series	M Series Keyed
R Series Keyed	N Series Keyed	03 Series Keyed	V Series	W Series Keyed	Cable assembly	K/S Series Keyed
REDEL F Series	P REDEL Series Keyed	D REDEL Series	01 Series Keyed	VAA Series	SAA Series	TAA Series

No reproduction or use without express permission of editorial or pictorial content, in any manner.
LEMO SA reserves the right to modify and improve specifications, at all times, without any notification.

勝特力材料 886-3-5753170
 勝特力电子(上海) 86-21-34970699
 勝特力电子(深圳) 86-755-83298787
[Http://www.100y.com.tw](http://www.100y.com.tw)