



产品编号 : 191930109

Product Description : VersaKrimp Ring
Tongue Terminal for 10-12 AWG Wire, Loose

系列号 : 19193

状态 : Active

Product Category : Ring and Spade
Terminals

工程编号 : C-328-10



文件和资源

图纸

图纸 191930109_sd.pdf

规格

产品规格 PS-19902-011-001.pdf

产品规格 PS-19902-013-001.pdf

产物环境合规

合规

GADSL/IMDS	Not Relevant
China RoHS	
EU ELV	Not Relevant
Low-Halogen Status	Low-Halogen per IEC 61249-2-21
REACH SVHC	Not Contained per D(2023)3788-DC (14 Jun 2023)
EU RoHS	Compliant per EU 2015/863

多部分产品合规性声明

- Eu RoHS
- REACH SVHC
- Low-Halogen

多部分行业合规性文件

- IPC 1752A Class C

- IPC 1752A Class D
- Molex Product Compliance Declaration
- IEC-62474
- chemSHERPA (xml)

欧盟 RoHS 合格证书

产品详情

常规

状态	活动
类别	Ring and Spade Terminals
系列	19193
说明	VersaKrimp Ring Tongue Terminal for 10-12 AWG Wire, Loose
个评论	Type I Non-insulated
关键字	Ring Terminal, Ring Terminals
产品系列	VersaKrimp Terminals and Splices
产品名称	VersaKrimp
类型	Ring
UPC	800753039278

机构

CSA	LR18689
UL	E32244

物理

筒型	Closed - Brazed
绝缘	无
材料 - 接合部位电镀	Tin
净重	1.490/g
包装形式	Bag
最薄镀层 - 接合部位	2.540µm
最薄镀层 - 端接	2.540µm
螺柱规格	10 (M5)
线径规格 (AWG)	10, 12
线缆尺寸mm ²	3.30-5.00

施工工具

全局

描述	产品编号
PremiumGrade Hand Crimp Tool for Krimptite/Versakrimp Terminals and Splices, 10-22 AWG and 6.0mm ² - 0.5mm ²	<u>0640030100</u>
Crimp Head for the AT-200 Pneumatic Hand Tool	<u>0640070100</u>
ServiceGrade Hand Crimp Tool - Ratchet	<u>0640160038</u>

This document was generated on Dec 29, 2023

MATERIAL NO. LOOSE PIECE	ENG. NO.	MATERIAL NO. TAPE MOUNTED	ENG. NO.	STUD	±.003 "S"	STOCK THICKNESS
191930101	C-328-04	-----	-----	4	.126	.040 (1.02)
191930103	C-328-06	191930105	C-328-06T	6	.146	
191930106	C-328-08	191930108	C-328-08T	8	.173	
191930109	C-328-10	191930111	C-328-10T	10	.198	
191930112	C-328-209	191930113	C-328-209T	209	.209	

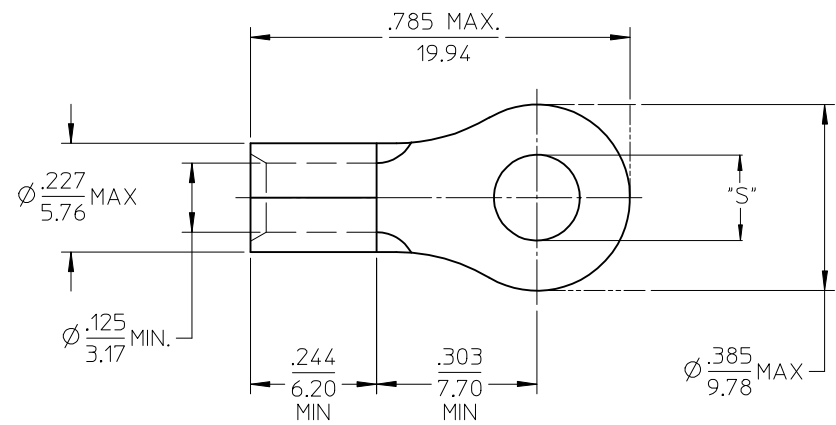
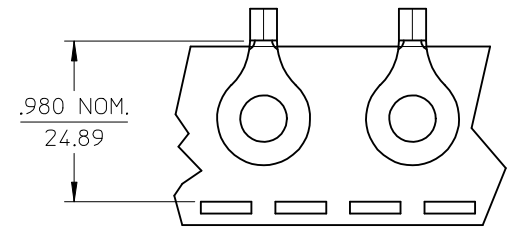

SALES DRAWING

- NOTE(S):
1. MATERIAL: COPPER
 2. PLATING: ELECTROPLATE TIN
 3. ALL DIMENSIONS IN INCHES/(MM).
 4. WIRE SIZE: 12-10 AWG
4.0-6.0 MM²

REVISED/UPDATE TO MX STD EC NO: ETC2003-0315 DRWN: DMYRICK 2003/08/20 CHKD: HEB 2003/08/21 APPR: RDEROSS 2003/08/21	QUALITY SYMBOLS	GENERAL TOLERANCES (UNLESS SPECIFIED)	SCALE 4:1	DESIGN UNITS INCH	THIRD ANGLE PROJECTION	REVISE ON CAD ONLY															
	▽ - 0 ∇ = 0	<table border="1"> <thead> <tr> <th></th> <th>mm</th> <th>INCH</th> </tr> </thead> <tbody> <tr> <td>4 PLACES</td> <td>± ---</td> <td>± ---</td> </tr> <tr> <td>3 PLACES</td> <td>± ---</td> <td>± .005</td> </tr> <tr> <td>2 PLACES</td> <td>± 0.13</td> <td>± .01</td> </tr> <tr> <td>1 PLACE</td> <td>± 0.25</td> <td>± ---</td> </tr> </tbody> </table>		mm	INCH	4 PLACES	± ---	± ---	3 PLACES	± ---	± .005	2 PLACES	± 0.13	± .01	1 PLACE	± 0.25	± ---	DIMENSION STYLE IN/MM DRAWN BY DLM DATE 03/06/13 CHECKED BY HEB DATE 03/06/13 APPROVED BY RWD DATE 03/06/13	TITLE RING TONGUE TERMINAL VERSAKRIMP 12-10 AWG MOLEX INCORPORATED		
			mm	INCH																	
	4 PLACES	± ---	± ---																		
3 PLACES	± ---	± .005																			
2 PLACES	± 0.13	± .01																			
1 PLACE	± 0.25	± ---																			
DRAFT WHERE APPLICABLE MUST REMAIN WITHIN DIMENSIONS	MATERIAL NO. (SEE CHART) DOCUMENT NO. SD-19193-023 SHEET NO. 1 OF 1																				
THIS DRAWING CONTAINS INFORMATION THAT IS PROPRIETARY TO MOLEX INCORPORATED AND SHOULD NOT BE USED WITHOUT WRITTEN PERMISSION																					