



产品编号：[430452423](#)

Product Description : Micro-Fit 3.0 Right-Angle Header, 3.00mm Pitch, Dual Row, 24 Circuits, with PCB Press-fit Metal Retention Clip, Gold, Glow-Wire Capable, Black

系列号：43045

状态：Active

Product Category : PCB Headers and Receptacles

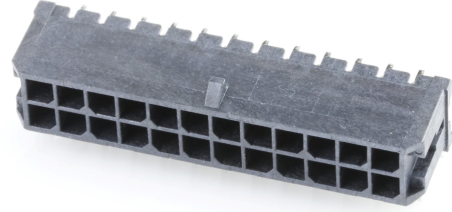

文件和资源

图纸

[图纸 430452423_sd.pdf](#)

[包装设计图 PK-70873-0313-001.pdf](#)

3D 模型和设计文件

[3D模型 430452423_stp.zip](#)

[符号足迹数据 SYM-43045-2421-001.zip](#)

[符号足迹数据 SYM-43045-2421_3-001.zip](#)

规格

[应用规格 AS-43045-001-001.pdf](#)

[产品规格 430450001-PS-K0-000.pdf](#)

[产品规格 430450001-PS-SP-000.pdf](#)

[产品规格 PS-43045-001.pdf](#)

[测试摘要 430450006-TS-000.pdf](#)

[测试摘要 TS-43045-001-001.pdf](#)

[测试摘要 TS-43045-002-001.pdf](#)

[测试摘要 TS-46235-001-001.pdf](#)

产物环境合规

合规

GADSL/IMDS	Compliant with Exemption 44; 34; 33
China RoHS	
EU ELV	Not Relevant
Low-Halogen Status	Low-Halogen per IEC 61249-2-21
REACH SVHC	Not Contained per D(2023)3788-DC (14 Jun 2023)

EU RoHS	Compliant per EU 2015/863
---------	---------------------------

多部分产品合规性声明

- Eu RoHS
- REACH SVHC
- Low-Halogen

多部分行业合规性文件

- IPC 1752A Class C
- IPC 1752A Class D
- Molex Product Compliance Declaration
- IEC-62474
- chemSHERPA (xml)

欧盟 RoHS 合格证书

产品详情

常规

状态	活动
类别	PCB Headers and Receptacles
系列	43045
说明	Micro-Fit 3.0 Right-Angle Header, 3.00mm Pitch, Dual Row, 24 Circuits, with PCB Press-fit Metal Retention Clip, Gold, Glow-Wire Capable, Black
应用	Power, Wire-to-Board

个评论	<p>High Temperature, Square Pin, Solder Type; This Molex product is manufactured from material that has the following ratings, tested by independent agencies:</p> <p>a) A Glow Wire Ignition Temperature (GWIT) of at least 775 deg C per IEC 60695-2-13. b) A Glow Wire Flammability Index (GWFI) above 850 deg C per IEC 60695-2-12 and hence complies with the requirements set out in the International Standard IEC 60335-1 5th edition - household and similar electrical appliances - safety, section 30 Resistance to heat and fire. The customers using this product must determine its suitability for use in their particular application through testing or other acceptable means as described in end-product glow-wire flammability test standard IEC 60695-2-11 and any applicable product end-use standard(s). If it is determined during the customer's evaluation of suitability, that higher performance is required, please contact Molex for possible product options.</p>
元件类型	PCB Header
产品系列	Micro-Fit Connector System
产品名称	Micro-Fit 3.0
UPC	800753843462

机构

CSA	LR19980
UL	E29179

电气

每触点最大电流	8.5A
电压 - 最大	600V

物理

断开	否
回路数 (已载入)	24
电路数 (最多)	24

颜色-树脂	黑色
耐用性(插拔次数) - 最多次数	30
阻燃性	94V-0
符合灼热丝规范	是
插配长度	10.06mm
材料 - 金属	Brass
材料 - 接合部位电镀	金牌
材料 - 终端电镀	Tin
材料 - 树脂	High Temperature Thermoplastic
净重	3.725/g
行数	2
方向	Right Angle
包装形式	Tray
PCB 定位器	是
PCB 保持力	是
推荐的 PCB 厚度	1.60mm
间距 - 插配接口	3.00mm
最薄镀层 - 接合部位	0.762µm
PCB 极性	是
有护墙的	Fully
可堆叠的	否
运行温度范围	-40° to +125° C
终端界面类型	Through Hole

进程

最长持续时间	30
无铅	SMC&WAVE
最大周期	3
最高温度	260

可配插/可连接使用的产品

可配插部件

描述	产品编号
----	------

Micro-Fit 3.0 Dual Row Receptacle Housings	<u>43025</u>
Micro-Fit TPA Receptacle Housings	<u>172952</u>

This document was generated on Jan 02, 2024

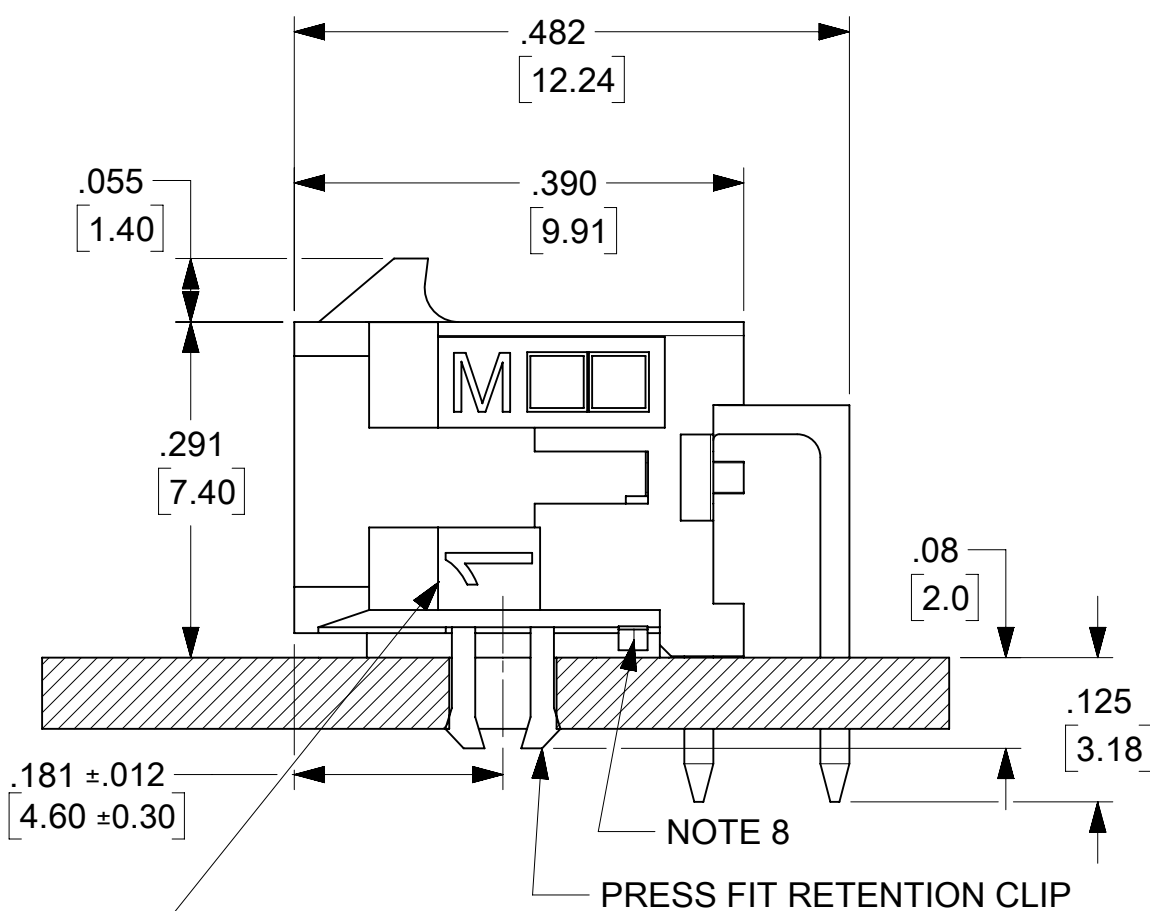
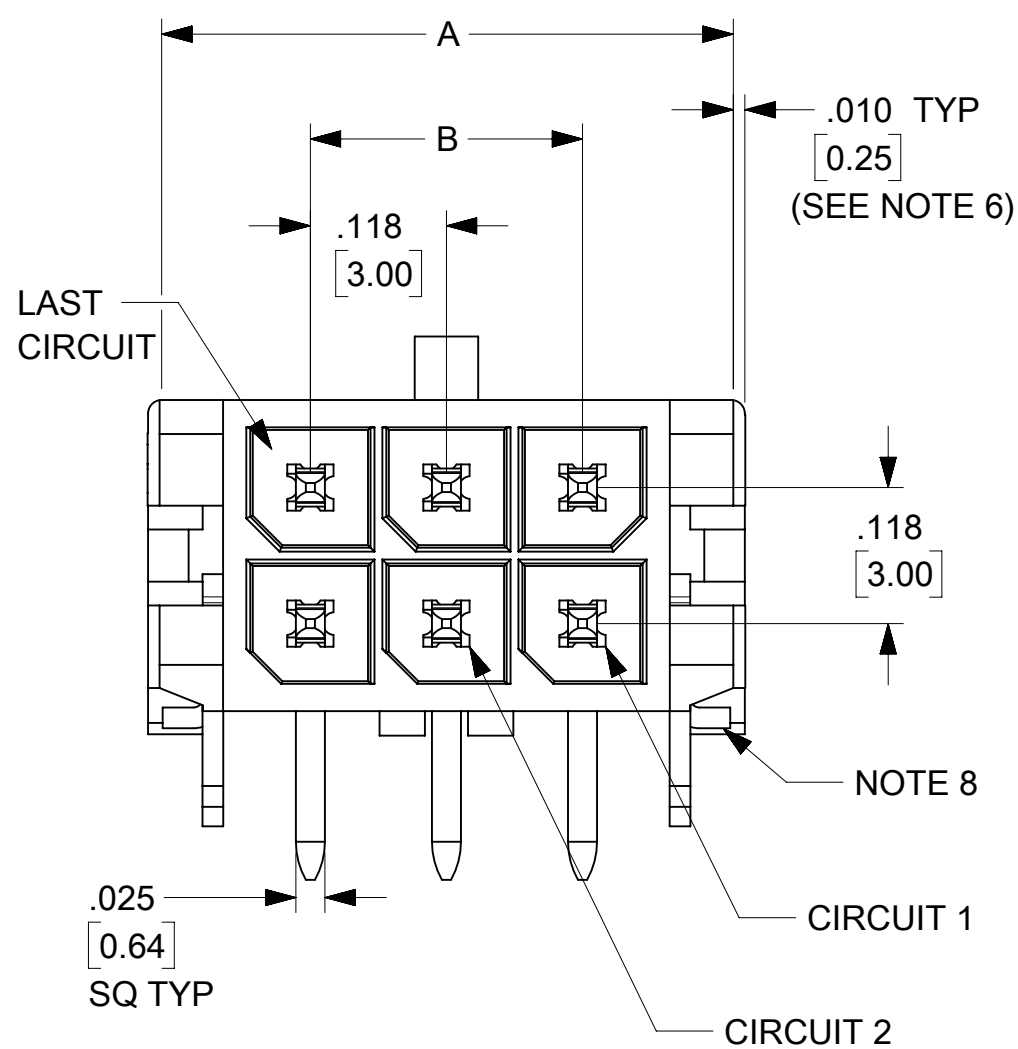
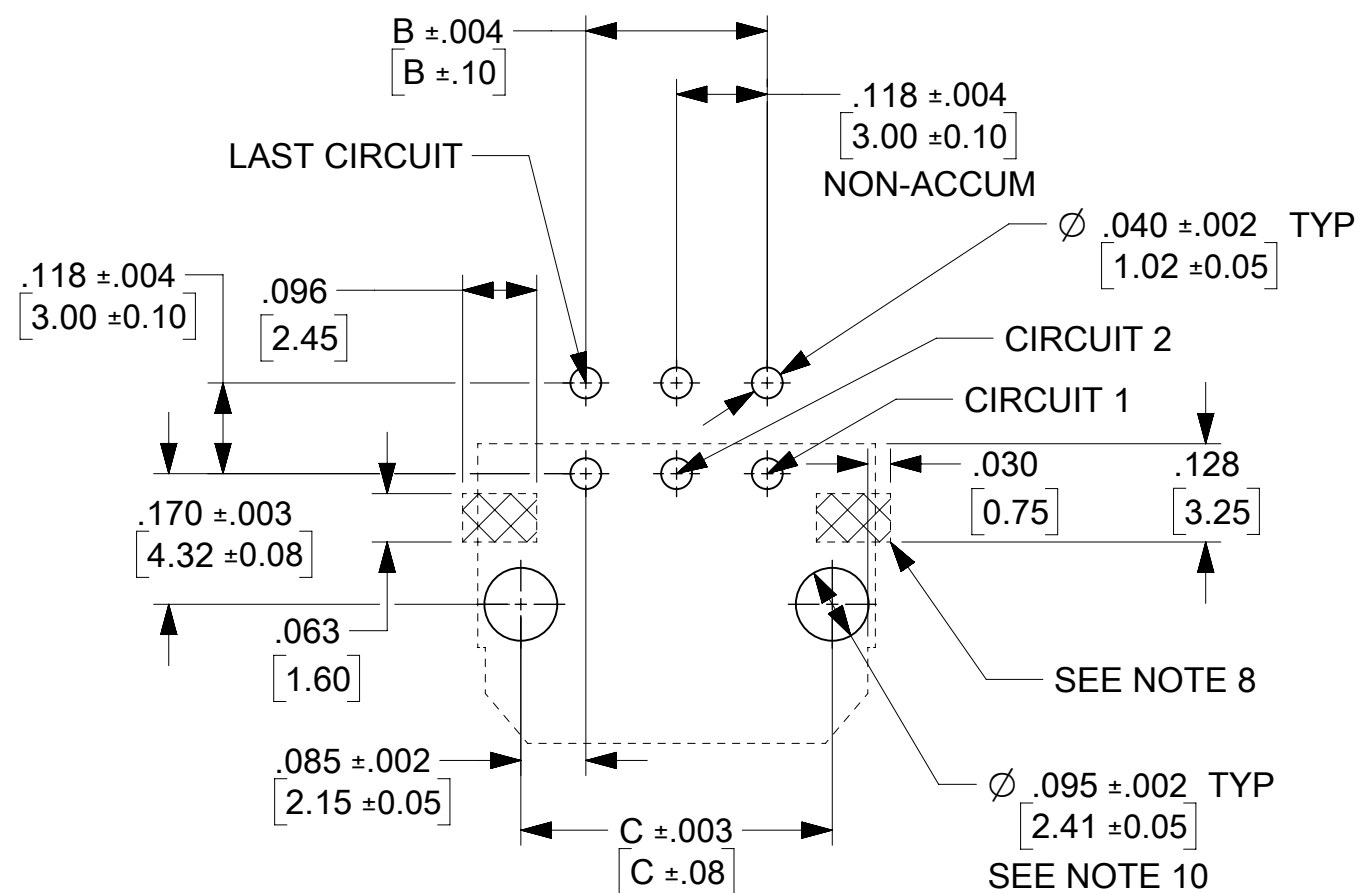
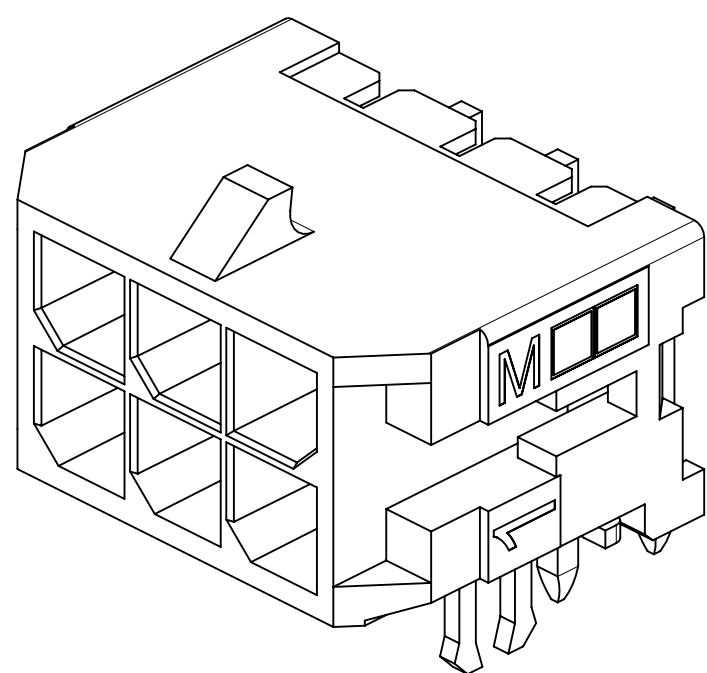
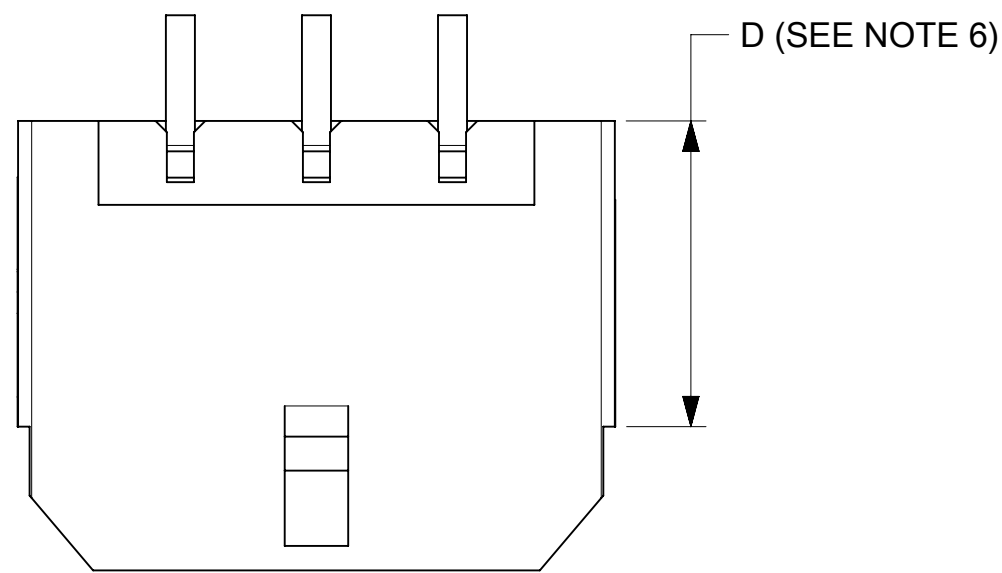

PCB LAYOUT: COMPONENT SIDE
RECOMMEND PCB THICKNESS: .062/1.57

CIRCUIT "1" IDENTIFIED ON THIS SURFACE
(APPROX. LOCATION SHOWN FOR REF.)

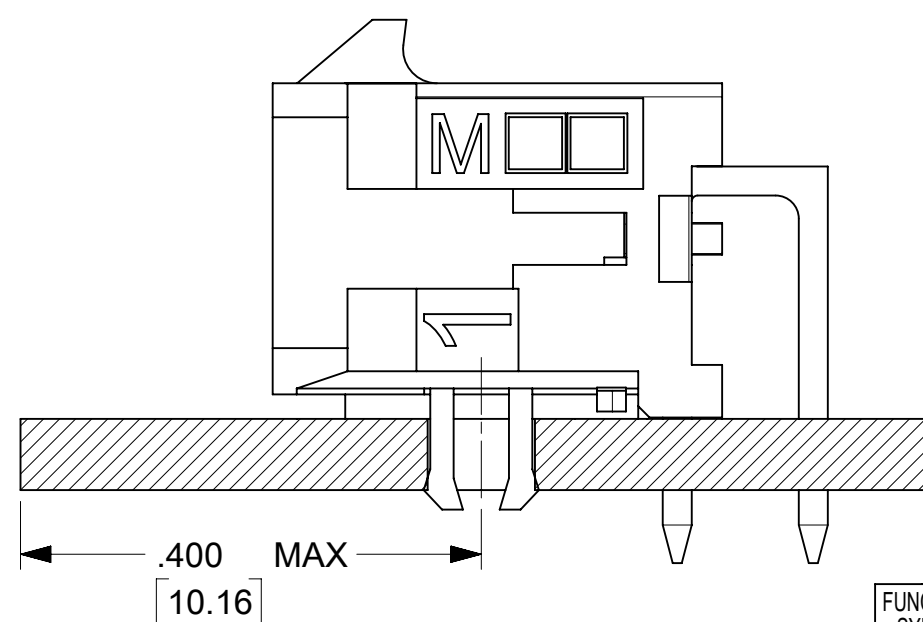

NOTES:

- HOUSING MATERIAL: GLASS FILLED LIQUID CRYSTAL POLYMER UL94V-0, COLOR: BLACK
TERMINAL MATERIAL: BRASS ALLOY
- FINISH: A = .000060/(0.00152) MIN. REFLOWED MATTE TIN OVER
.000050/(0.00127) MIN. NICKEL PLATE
(FINISH IS BRIGHT IN APPEARANCE, THICKNESS AS APPLIED PRIOR TO REFLOW).
B = .000015/(0.00038) MIN SELECT GOLD IN CONTACT AREA,
.000100/(0.00254) MIN. SELECT MATTE TIN ON SOLDER TAILS,
BOTH OVER .000050/(0.00127) MIN. NICKEL PLATE
C = .000030/(0.00076) MIN SELECT GOLD IN CONTACT AREA,
.000100/(0.00254) MIN. SELECT MATTE TIN ON SOLDER TAILS,
BOTH OVER .000050/(0.00127) MIN. NICKEL PLATE
D = .000100/(0.00254) MIN. MATTE TIN OVER
.000050/(0.00127) MIN. NICKEL PLATE.
- PRODUCT SPECIFICATION: PS-43045
- TRAY PACKAGED: SEE MOLEX DRAWING PK-70873-0313
- MATES WITH MICRO-FIT (3.0) RECEPTACLE SERIES 43025
- CIRCUIT SIZES 2-6: 'D' IS .265/6.74 FOR .010/(0.25) STEP
CIRCUIT SIZES 8-24: 'D' IS .063/(1.60) FOR .010/(0.25) STEP
- TO AVOID INTERFERENCE BETWEEN RECEPTACLE AND PCB, HEADER MUST BE PLACED WITHIN .400/(10.16) MAX. FROM EDGE OF PCB, AS SHOWN IN LOCATION DETAIL.
- METAL TAB MAY BE FLUSH WITH PCB. NO EXPOSED TRACES OR VIAS ALLOWED NEAR THESE AREAS.
- THIS PART CONFORMS TO CLASS B REQUIREMENTS OF COSMETIC SPECIFICATION PS-45499-002.
- FOR BEST RETENTION TO PCB, HOLES SHOULD BE PTH AND CLIPS SHOULD BE SOLDERED
- TEXT ON PART IS FOR REFERENCE ONLY. TEXT AND TEXT LOCATION MAY VARY DEPENDING ON PART NUMBER AND/OR TOOL

CKTS	A	B	C
02	.262 6.65	— NA	.169 4.30
04	.380 9.65	.118 3.00	.287 7.30
06	.498 12.65	.236 6.00	.405 10.30
08	.616 15.65	.354 9.00	.524 13.30
10	.734 18.65	.472 12.00	.642 16.30
12	.852 21.65	.591 15.00	.760 19.30
14	.970 24.65	.709 18.00	.878 22.30
16	1.088 27.65	.827 21.00	.996 25.30
18	1.206 30.65	.945 24.00	1.114 28.30
20	1.325 33.65	1.063 27.00	1.252 31.30
22	1.443 36.65	1.181 30.00	1.350 34.30
24	1.561 39.65	1.299 33.00	1.469 37.30

CKTS	FINISH A	FINISH B	FINISH C	FINISH D
	MATERIAL NO:	MATERIAL NO:	MATERIAL NO:	MATERIAL NO:
02	43045-0221	43045-0222	43045-0223	
04	43045-0421	43045-0422	43045-0423	
06	43045-0621	43045-0622	43045-0623	43045-0658
08	43045-0821	43045-0822	43045-0823	
10	43045-1021	43045-1022	43045-1023	
12	43045-1221	43045-1222	43045-1223	
14	43045-1421	43045-1422	43045-1423	
16	43045-1621	43045-1622	43045-1623	
18	43045-1821	43045-1822	43045-1823	43045-1858
20	43045-2021	43045-2022	43045-2023	
22	43045-2221	43045-2222	43045-2223	
24	43045-2421	43045-2422	43045-2423	

FUNCTIONAL SYMBOLS	THIS DRAWING CONTAINS INFORMATION THAT IS PROPRIETARY TO MOLEX ELECTRONIC TECHNOLOGIES, LLC AND SHOULD NOT BE USED WITHOUT WRITTEN PERMISSION			
	DIMENSION UNITS	SCALE	CURRENT REV DESC: REDRAWN, ADD NOTES 10 & 11	
	$\frac{F}{A} = 0$	INCH/MM	NTS	
	$\frac{F}{C} = 0$	GENERAL TOLERANCES (UNLESS SPECIFIED)		
DIVISIONAL SYMBOLS		MM	INCH	
	$\frac{F}{P} = 0$	4 PLACES ±	±	
		3 PLACES ±	± 0.01	
		2 PLACES ±	0.25 ± 0.014	
	1 PLACE ±	0.36 ±		
	0 PLACES ±	±		
	ANGULAR TOL	± 0.5 °		
DRAFT WHERE APPLICABLE MUST REMAIN WITHIN DIMENSIONS		THIRD ANGLE PROJECTION	DRAWING	SERIES
			C-SIZE	43045

EC NO: 736143			
DRWN: SETHH6	2022/12/14		
CHK'D: MKIPPER	2023/01/24		
APPR: FSMITH	2023/01/26		
INITIAL REVISION:			
DRWN: SAMIEC	2000/03/15		
APPR: FSMITH	2016/02/26		
DOCUMENT NUMBER		DOC TYPE	DOC PART
SD-43045-008		PSD	000
MATERIAL NUMBER		CUSTOMER	SHEET NUMBER
SEE CHART		GENERAL MARKET	1 OF 1