

Model 3268, 3271 & 3272 Miniature Rivet Type Banana Plugs With Swaging Information

勝特力材料 886-3-5753170
 勝特力电子(上海) 86-21-34970699
 勝特力电子(深圳) 86-755-83298787
[Http://www.100y.com.tw](http://www.100y.com.tw)

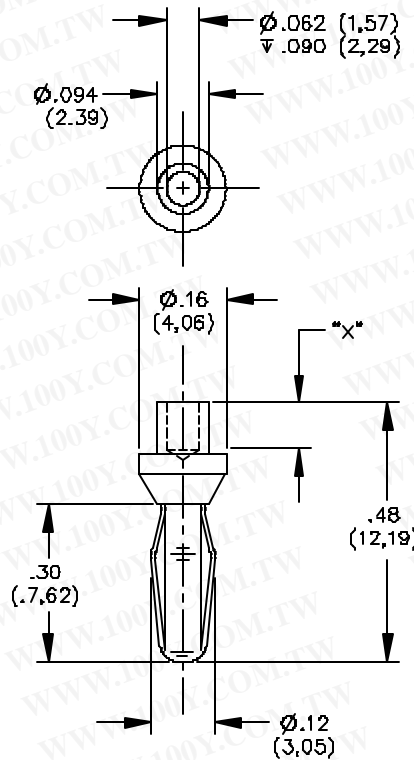

FEATURES:

- Excellent for riveting to panels or boards.
- Banana features gold plated Beryllium Copper for long insertion life and corrosion resistance.

Model Number:	Rec. Panel Thickness:	"X" Dimension:
3268	.062" (1,57mm)	.094" (2,39mm)
3271	.093" (2,36mm)	.125" (3,18mm)
3272	.125" (3,18mm)	.156" (3,96mm)

MATERIALS:

Body: Brass, Gold Plated

Spring: Beryllium Copper, Gold Plated

RATINGS:

Operating Voltage: 2500 VDC

Current: 5 Amperes Max.

ORDERING INFORMATION: Models 3268, 3271, 3272

Sold in packages of 10

Note: Swage tool is not supplied by Pomona. The recommended swage tool dimensional drawing 3520 is attached for reference.

All dimensions are in inches. Tolerances (except noted): .xx = ±.02" (.51 mm), .xxx = ±.005" (.127 mm).

All specifications are to the latest revisions. Specifications are subject to change without notice.

Registered trademarks are the property of their respective companies. Made in USA

勝特力材料 886-3-5753170
 勝特力电子(上海) 86-21-34970699
 勝特力电子(深圳) 86-755-83298787
 Http://www.100y.com.tw

Miniature Rivet Type Banana Plugs With Swaging Information

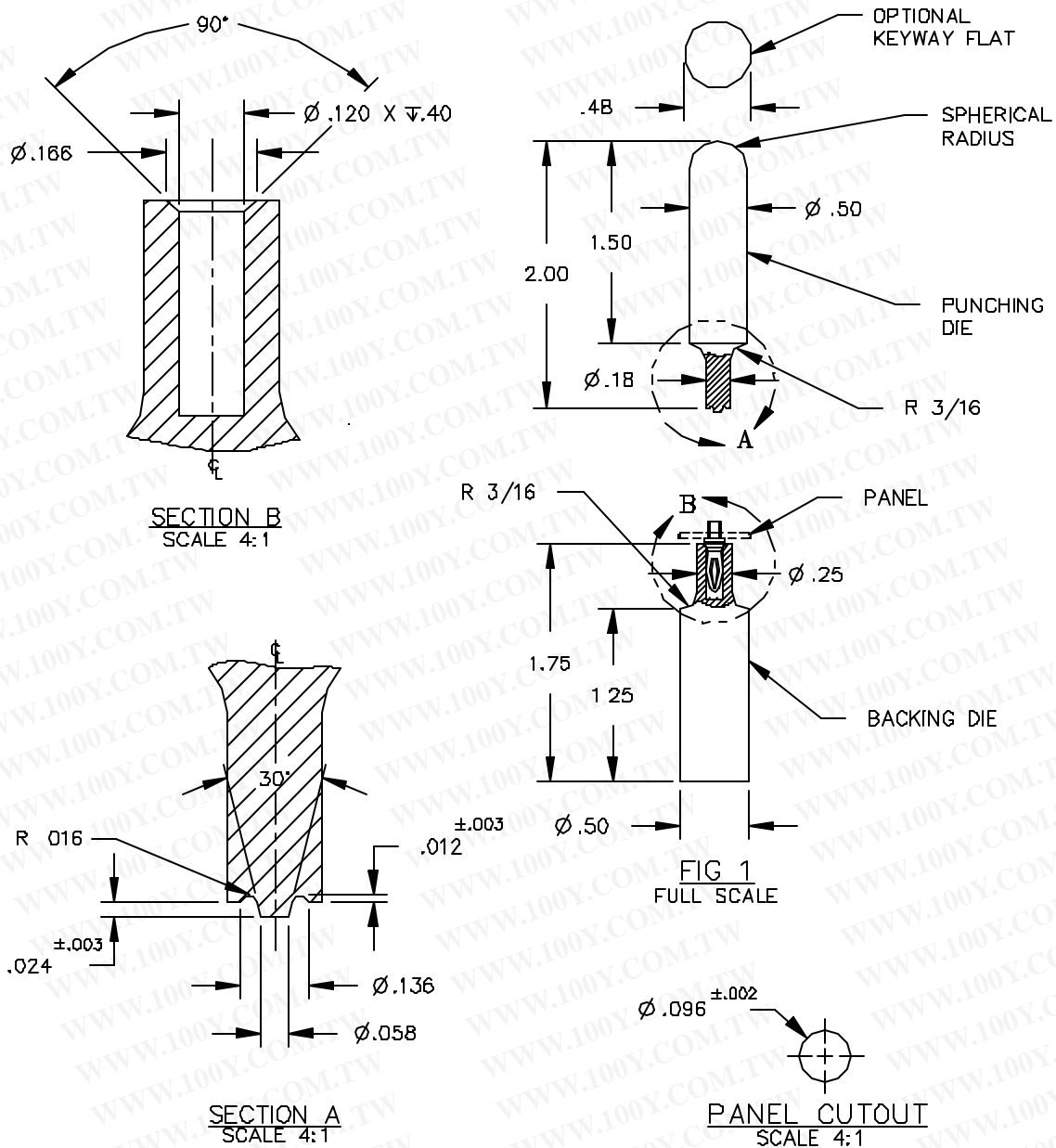

1. RECOMMENDED MATERIAL: 4130 CHROMIUM STEEL ALLOY, D2 STEEL OR EQUIVALENT TOOL STEEL, HEAT TREAT TO 60-62RC HARDNESS.
2. OVERALL DIMENSIONS OF PUNCHING AND BACKING DIES AS SHOWN IN FIG 1 ARE FOR REFERENCE ONLY AND CAN BE CHANGED TO FIT SPECIFIC TOOLING; HOWEVER, DIMENSIONS AS SHOWN IN VIEWS A & B MUST BE MAINTAINED FOR PROPER SWAGING.
3. SURFACE FINISH: $63\sqrt{\text{ }}$ OR FINER FOR SECTIONAL VIEWS A & B.