

REVISIONS				
P.	LTN	DESCRIPTION	DATE	APVD
AS		REVISED PER ECR-19-011518	28AUG2019	BDA SF

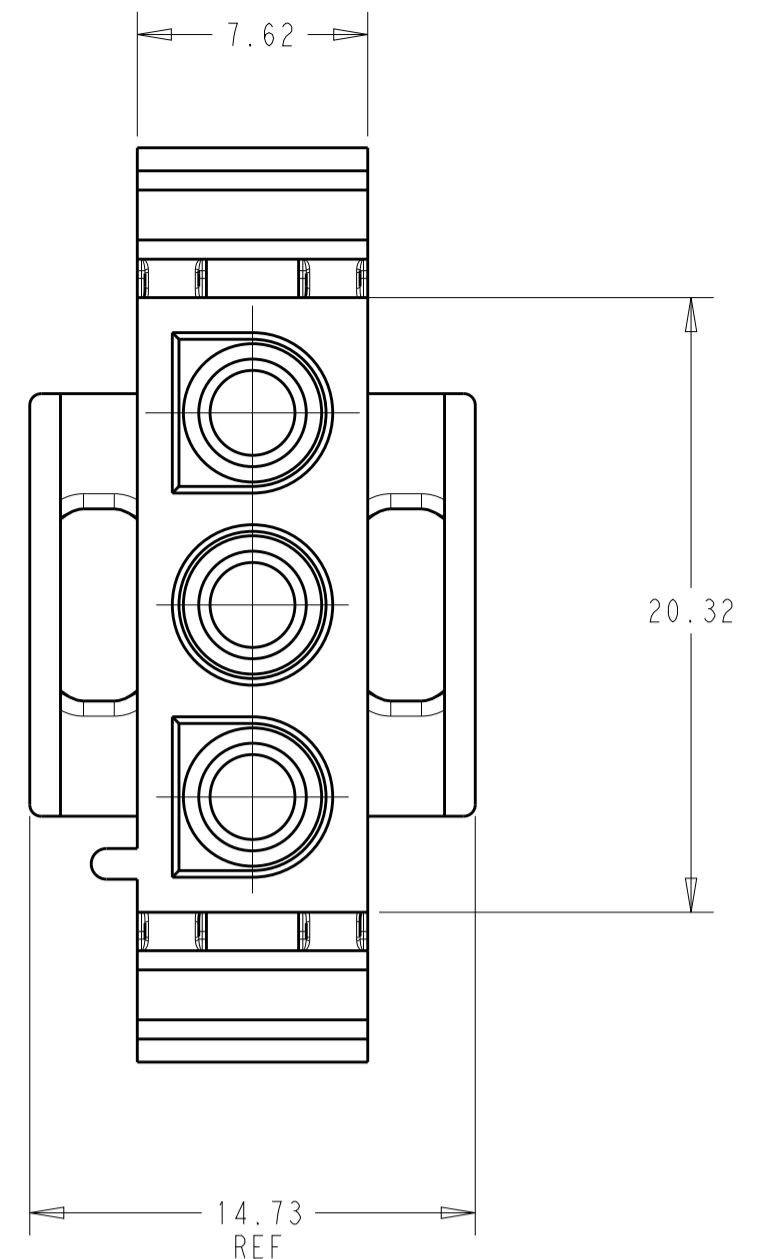

- MATES WITH APPROPRIATE UNIVERSAL MATE-N-LOCK™ CAP OR HEADER.
  - SMALL NICKS ARE PERMITTED ON THE CIRCUIT TOWER WHICH COULD INCREASE THE INITIAL HOUSING MATING FORCE BY UP TO 4.4 NEWTONS (1.0 LBS.). NO INDIVIDUAL NICKED TOWER SHALL INCREASE THIS FORCE BY OVER 2.2 NEWTONS (.5 LBS).
  - DIMENSIONS SHOWN REPRESENT PRODUCT IN DRY, AS MOLDED, CONDITION. ADDITIONAL 2% GROWTH DUE TO SUBSEQUENT MOISTURE ABSORPTION MAY OCCUR AND SHOULD BE ACCOUNTED FOR.
- △ 4 FOUR RIBS EQUALLY SPACED, NO SPECIFIC ORIENTATION. NO RIBS OR SIX RIBS EQUALLY SPACED, NO SPECIFIC ORIENTATION, OPTIONAL.
  - △ 5 UNDERWRITERS RECOGNIZED COMPONENT LOGO AND CSA CERTIFICATION LOGO TO BE LOCATED ONCE ON ANY SIDE OF HOUSING.
  - △ 6 SHOWN FOR CONVENIENCE: AMP OR TE LOGO MAY BE ON ANY EXTERNAL SURFACE.

勝特力電材超市-龍山店 886-3-5773766  
 勝特力電材超市-光復店 886-3-5729570  
 勝特力電子(上海) 86-21-34970699  
 勝特力電子(深圳) 86-755-83298787  
<http://www.100y.com.tw>

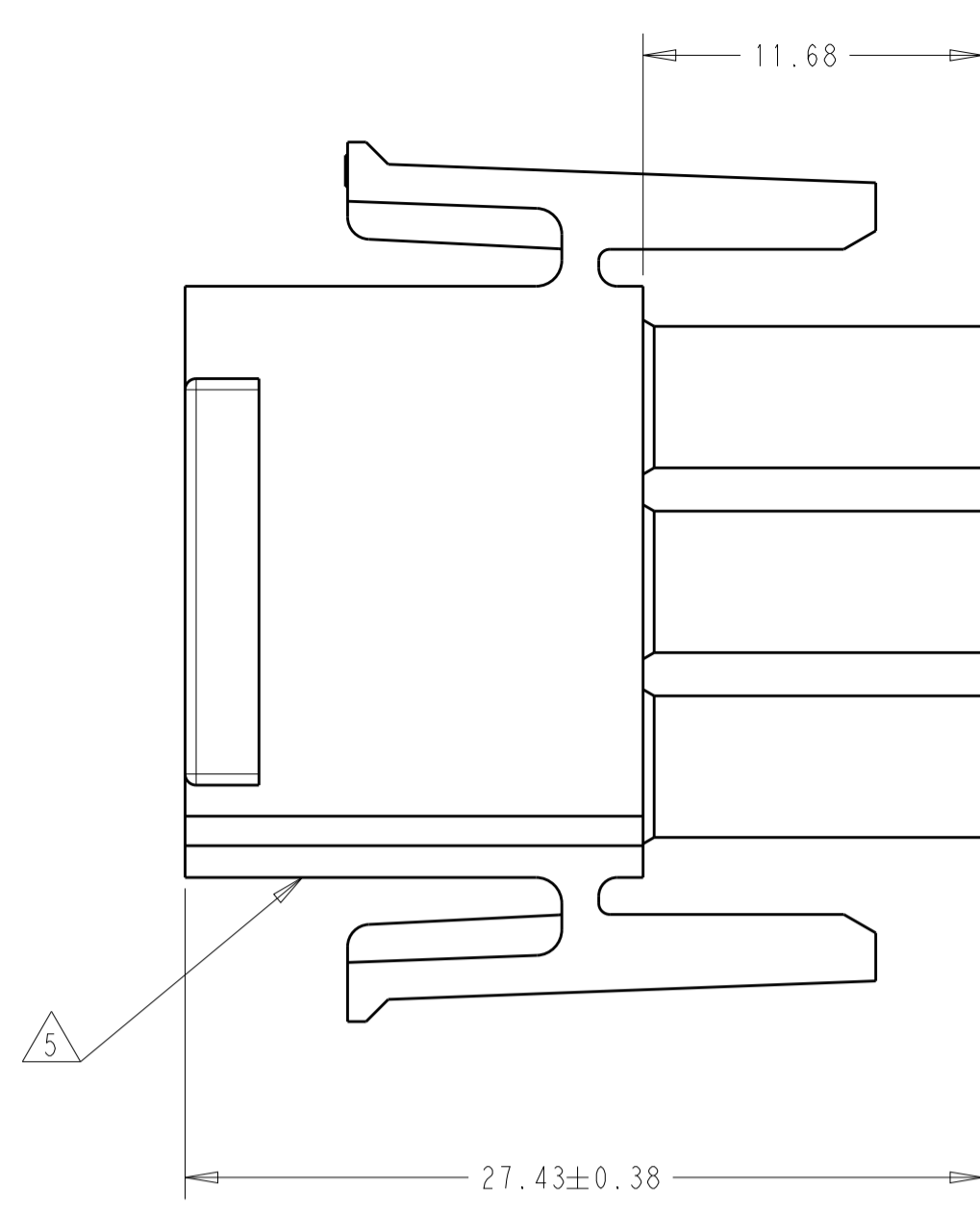
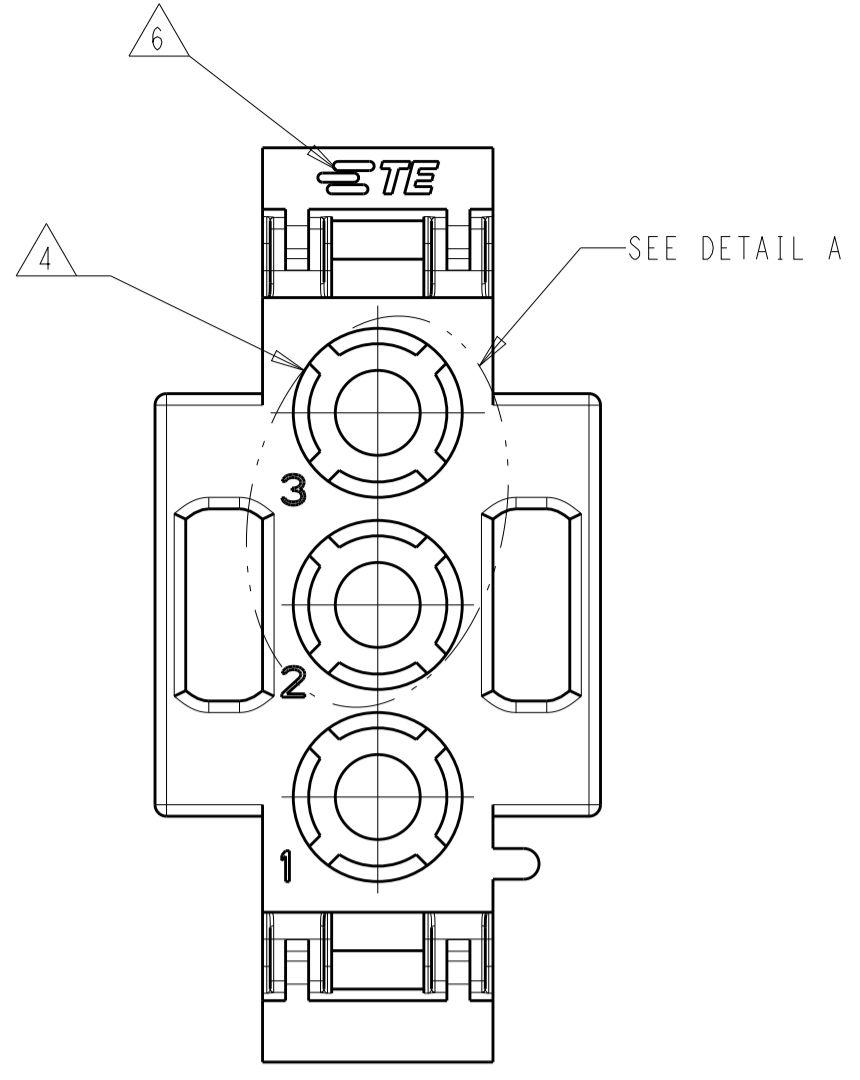
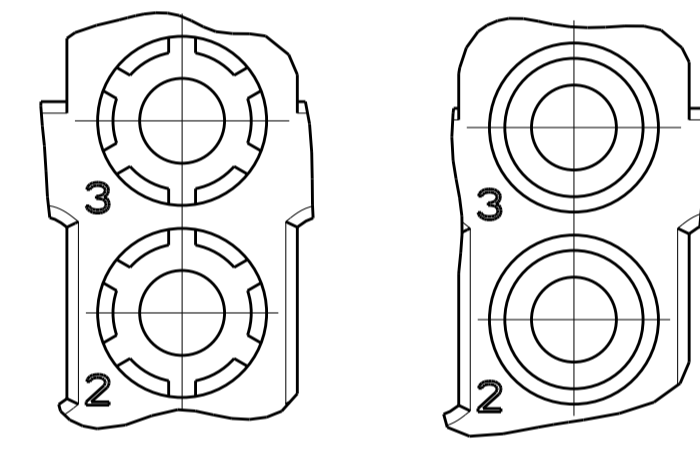
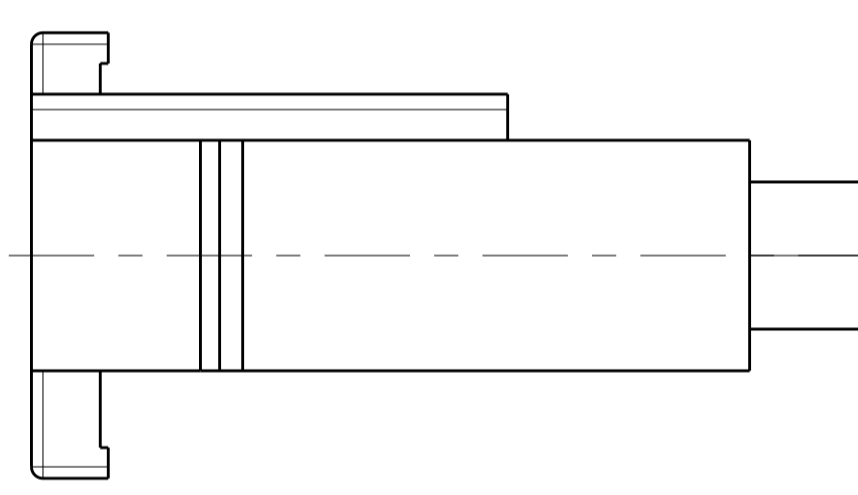

DETAIL A  
OPTIONAL CONSTRUCTIONS

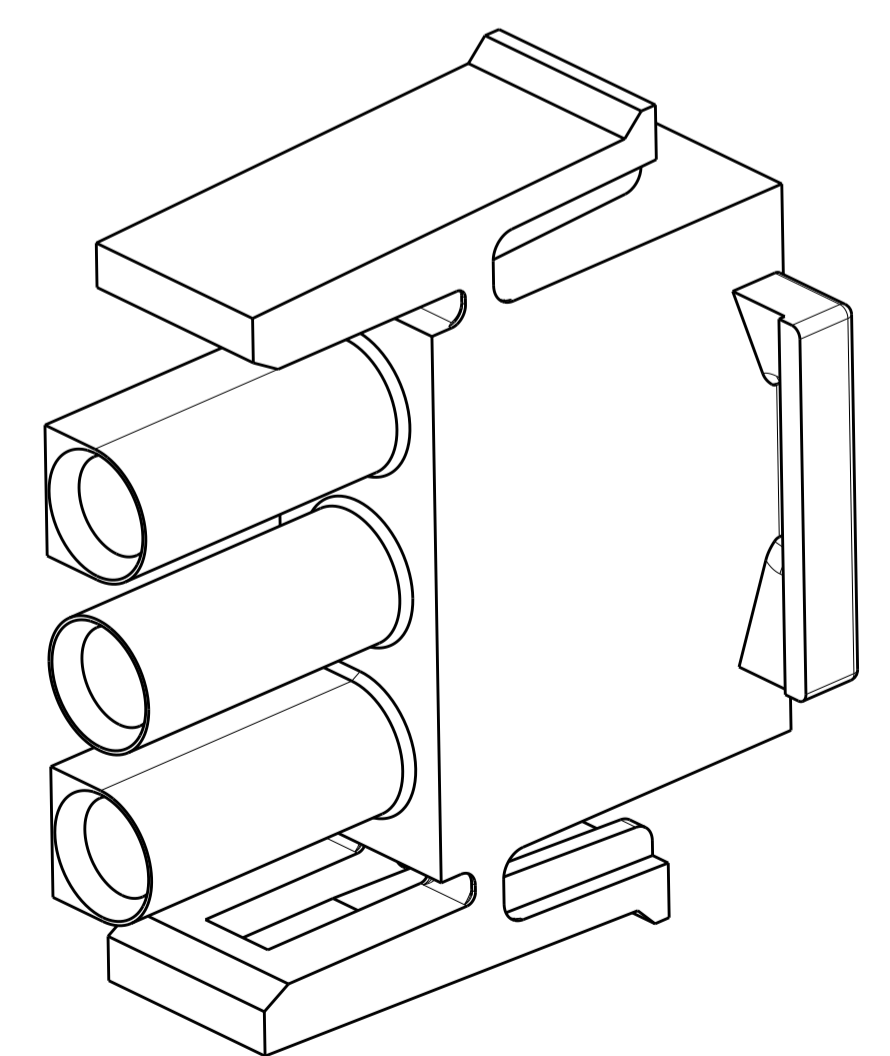

BLACK	1-480700-9
GRAY	1-480700-8
BLUE	1-480700-6
GREEN	1-480700-5
YELLOW	1-480700-4
ORANGE	1-480700-3
RED	1-480700-2
BROWN	1-480700-1
NATURAL	1-480700-0
COLOR	PART NUMBER

THIS DRAWING IS A CONTROLLED DOCUMENT.		OWN: B. WEAVER 08MAY2019	TE Connectivity	
DIMENSIONS: mm		CHK: S. FERNANDES 08MAY2019		
TOLERANCES UNLESS OTHERWISE SPECIFIED:		APVD: T. BENCHOFF 08MAY2019	NAME: PLUG, 3 CIRCUIT, UNIVERSAL MATE-N-LOCK	
0 PLC ±	1 PLC ±	PRODUCT SPEC	SIZE: CAGE CODE: DRAWING NO: RESTRICTED TO	
2 PLC ±0.13	3 PLC ±	APPLICATION SPEC	A   00779 ©=480700	
4 PLC ±	ANGLES ±40°/30°	WEIGHT	SCALE: 4:1 SHEET 1 OF 2 REV: AS	
MATERIAL: NYLON UL 94V-2	FINISH	CUSTOMER DRAWING		

REVISIONS				
P.	LTN	DESCRIPTION	DATE	APVD
-	-	SEE SHEET 1	-	-

1. STAMP NUMBERS 3.18 HIGH AT WIRE END OF HOUSING (12 POINT DAVID TYPE).
2. CHARACTERS TO BE STAMPED ON HOUSING IN A MANNER AS TO BE READ FROM WIRE END ONLY.
3. VIOLET, BLACK, BROWN, AND BLUE COLORED BLOCKS TO BE STAMPED WITH WHITE CHARACTERS. ALL OTHER COLORED BLOCKS TO BE STAMPED WITH BLACK CHARACTERS.

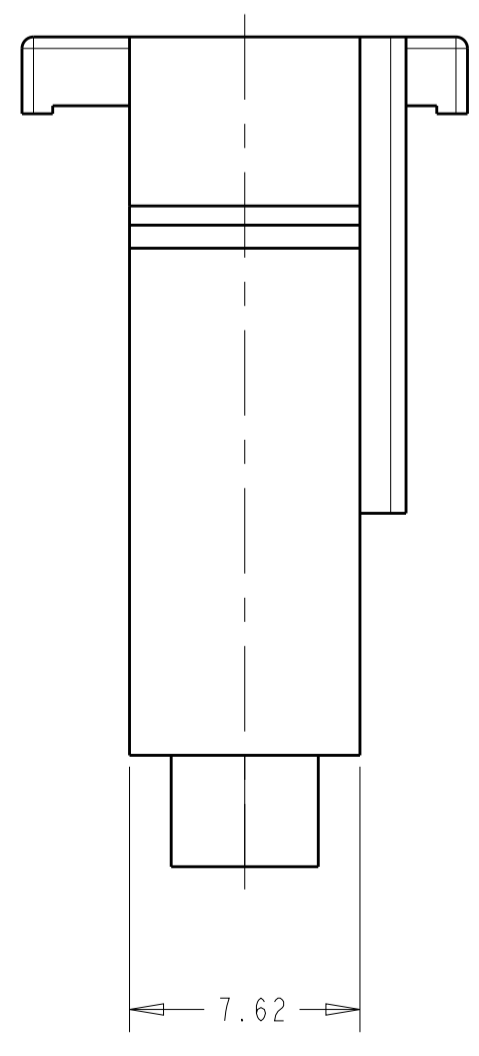
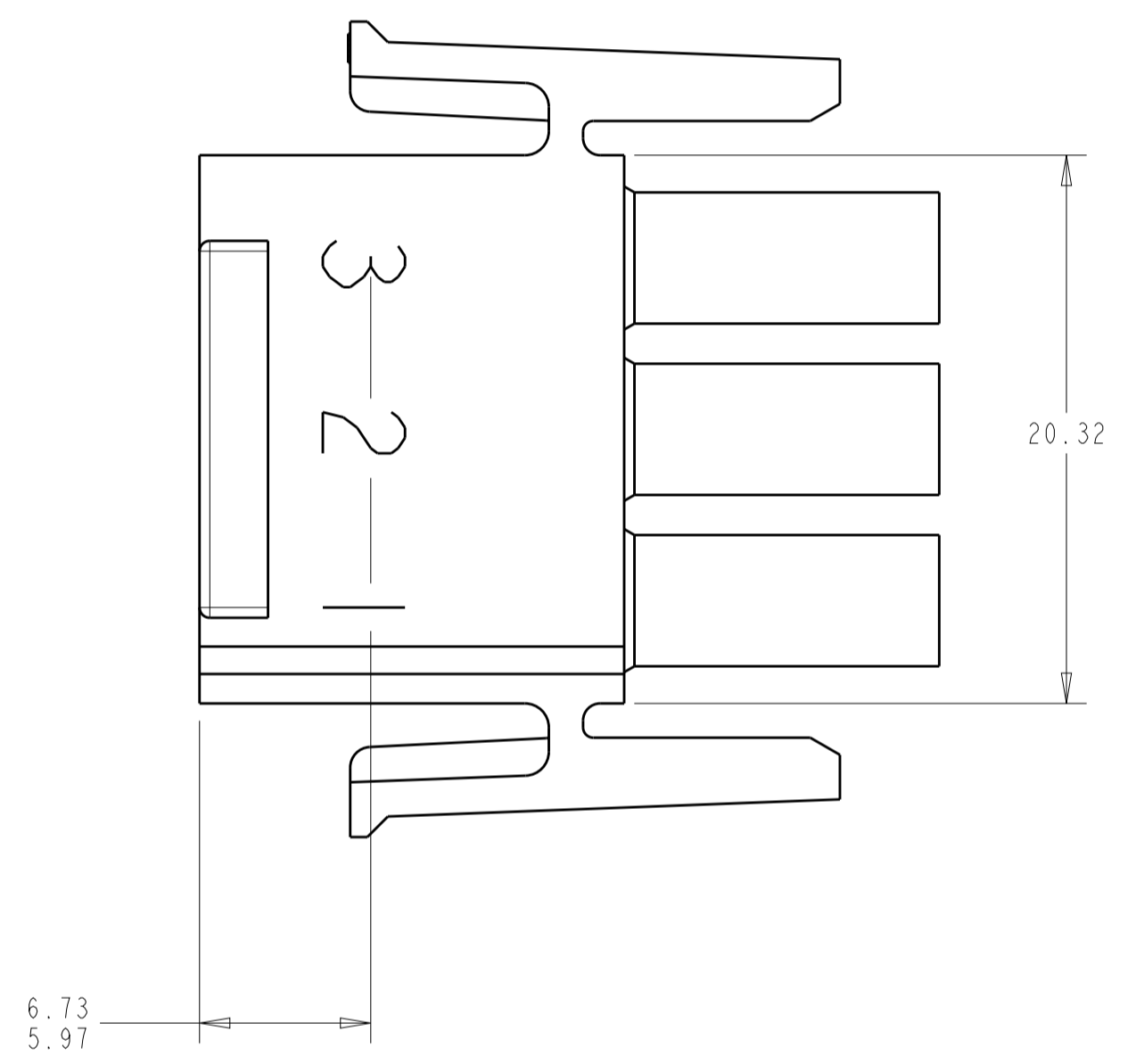
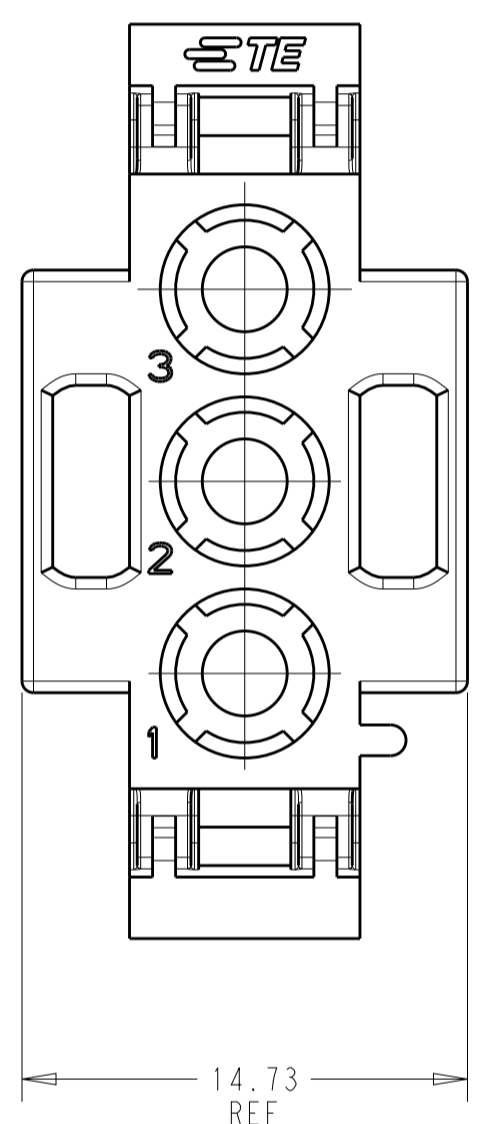
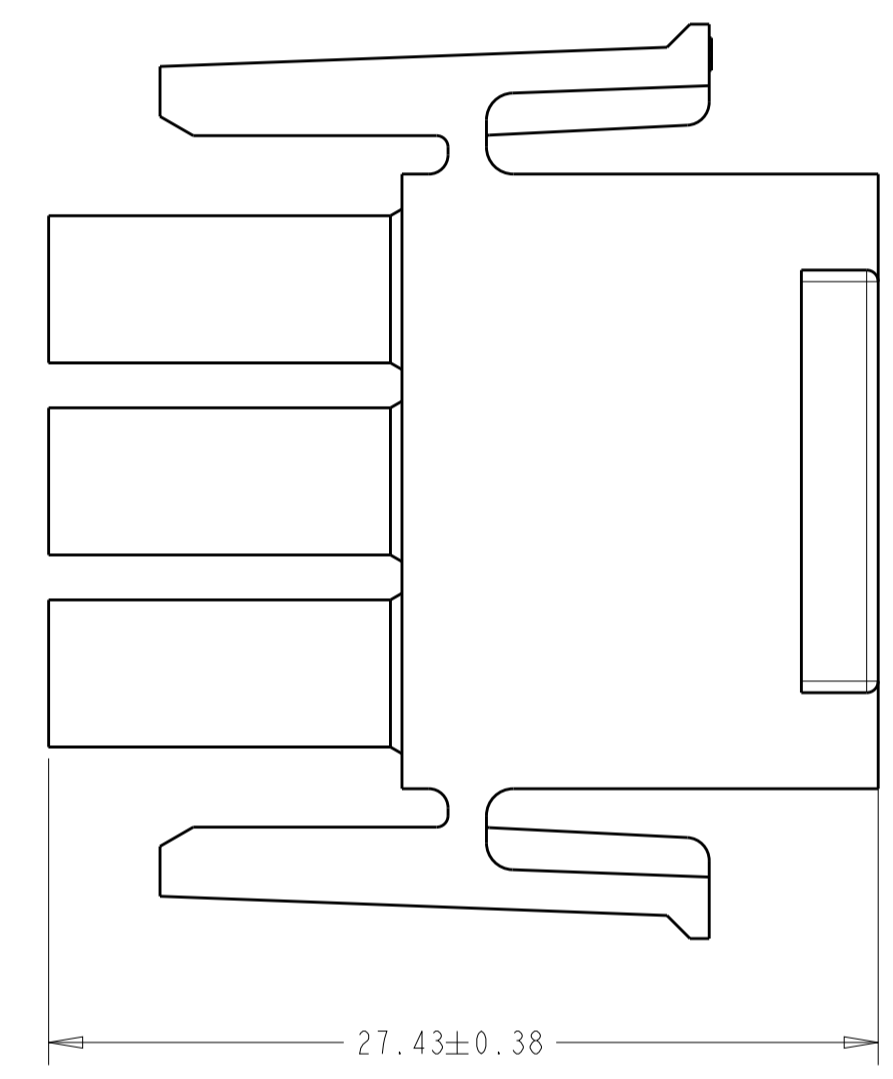
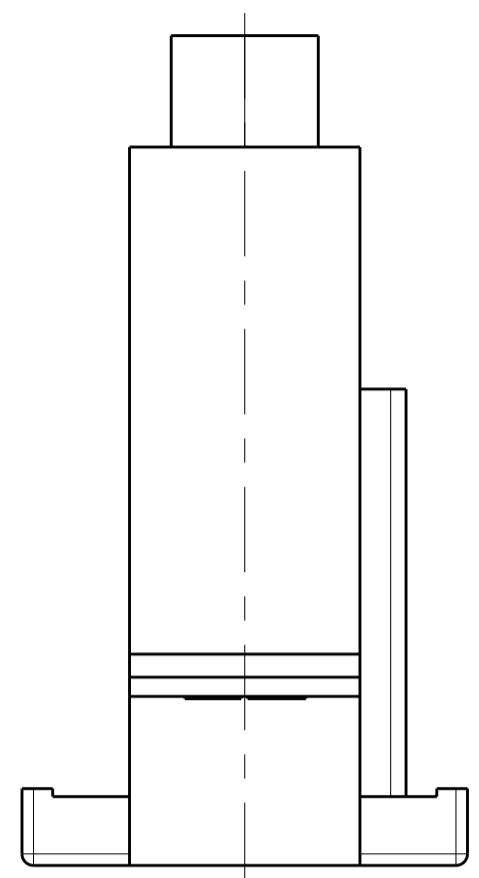

NATURAL	2-480700-0
COLOR	PART NUMBER

THIS DRAWING IS A CONTROLLED DOCUMENT.		DWN: B. WEAVER 08MAY2019 CHK: S. FERNANDES 08MAY2019 APVD: T. BENOIST 08MAY2019	NAME: PLUG, 3 CIRCUIT, UNIVERSAL MATE-N-LOCK PRODUCT SPEC: - APPLICATION SPEC: - SIZE: A   00779   C=480700 CAGE CODE: - DRAWING NO: - RESTRICTED TO: -
DIMENSIONS: mm 	TOLERANCES UNLESS OTHERWISE SPECIFIED: 0 PLC ± 1 PLC ± 2 PLC ±0.13 3 PLC ± 4 PLC ± ANGLES ±40°30'	MATERIAL: NYLON UL 94V-2 FINISH: - WEIGHT: - CUSTOMER DRAWING	SCALE: 4:1 SHEET: 2 OF 2 REV: AS



**NOTE**

*All numerical values are in metric units [with U.S. customary units in brackets]. Dimensions are in millimeters [and inches]. Unless otherwise specified, dimensions have a tolerance of  $\pm 0.13$  [ $\pm .005$ ] and angles have a tolerance of  $\pm 2^\circ$ . Figures and illustrations are for identification only and are not drawn to scale.*

## 1. INTRODUCTION

This specification covers the requirements for application of Universal MATE-N-LOK\* housings, contacts, and printed circuit (PC) board headers. The housings are available in 1- through 15-circuit versions and are intended for use in wire-to-wire (panel mounted or free hanging) or wire-to-board applications. The vertical pin and socket headers are available in 2- through 15-circuit versions and are intended for board-to-wire applications. The right-angle pin and socket headers are available in 2- through 8-circuit in-line versions and are intended for board-to-wire applications.

Optional terminal position assurance (TPA) accessories are available to install onto the housing. These devices provide added security to ensure proper contact insertion and retention in the circuit cavities.

When corresponding with TE Connectivity Personnel, use the terminology provided in this specification to facilitate inquiries for information. Basic terms and features of this product are provided in Figure 1.

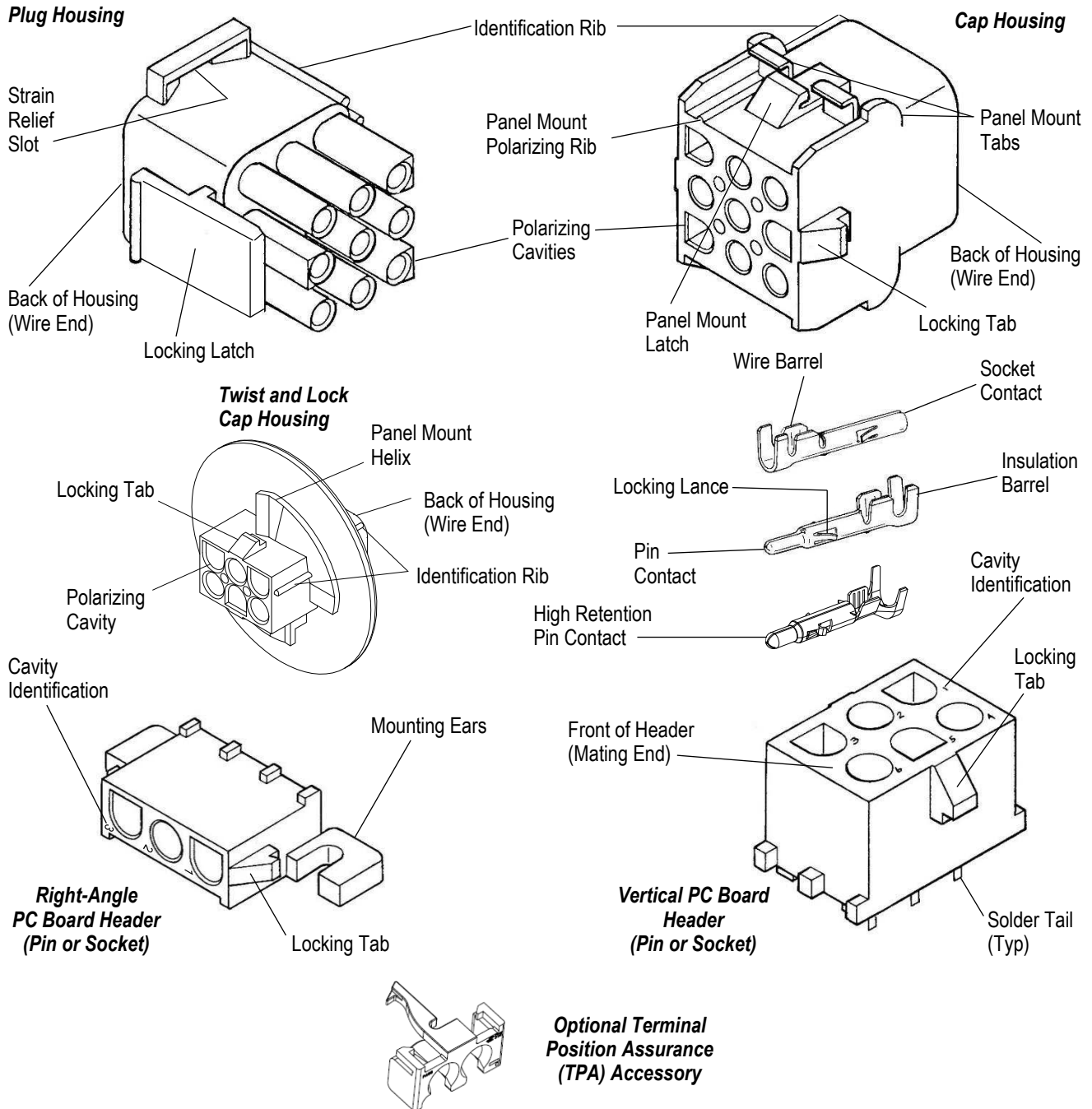

Figure 1

## 2. REFERENCE MATERIAL

### 2.1. Revision Summary

This paragraph is reserved for a revision summary covering the most recent additions and changes made to this specification which include the following:

- Updated Paragraph 1, Figure 1, Paragraph 2.5, and Paragraph 3.9 with TPA information.
- Update Paragraph 3.3.G and Figure 4 with O-Crimp information.

## 2.2. Customer Assistance

Reference Product Base Part Number 480702 and Product Code 1318 are representative numbers of the Universal MATE-N-LOK product line. Use of these numbers will identify the product line and help you to obtain product and tooling information. Such information can be obtained through a local TE Representative, by visiting our website at [www.te.com](http://www.te.com), or by calling PRODUCT INFORMATION at the number at the bottom of page 1.

## 2.3. Drawings

Customer Drawings for product part numbers are available from the service network. If there is a conflict between the information contained in the Customer Drawings and this specification or with any other technical documentation supplied, the information contained in the Customer Drawings takes priority.

## 2.4. Specifications

Product Specifications [108-1031](#) (for connectors) and [108-1053](#) (for headers), provides product performance requirements and test result information.

## 2.5. Instructional Material

The following list includes available instruction sheets (408-series) that provide assembly procedures for product, and operation, maintenance and repair of tooling; and customer manuals (409-series) that provide setup, operation, and maintenance of machines.

- [408-2095](#) Hand Crimping Tool 69710-1
- [408-3295](#) Preparing Reel of Contacts for Application Tooling
- [408-3320](#) Universal MATE-N-LOK Strain Relief Assembly and Keying Plug
- [408-3392](#) Universal MATE-N-LOK Splash Proof Seals
- [408-7300](#) MATE-N-LOK Contact and Housing Selection Charts
- [408-7424](#) Checking Terminal Crimp Height or Gaging Die Closure
- [408-7714](#) Universal MATE-N-LOK Connectors
- [408-7984](#) Insertion Tool 455830-1
- [408-8040](#) Heavy Duty Miniature Quick-Change Applicators (Side-Feed Type)
- [408-8053](#) Conversion Guide for Miniature Quick-Change Applicators
- [408-8059](#) General Preventive Maintenance for Applicators
- [408-8547](#) CERTI-CRIMP\* II Straight Action Hand Tools
- [408-9433](#) Crimping Die Assemblies 58380-1 and 58380-2
- [408-9591](#) Hand Crimping Tool 58439-1
- [408-9816](#) Handling of Reeled Products
- [408-10049](#) Extraction Tool 1804030-1
- [408-143222](#) Instruction Sheet – Universal MATE-N-LOK TPA Assembly
- [409-5842](#) AMP-O-LECTRIC\* Model "G" Terminating Machines 354500-[ ]
- [409-5852](#) AMPOMATOR\* CLS III-G Lead-Making Machine 122500-[ ]
- [409-5870](#) Crimp Quality Monitors (CQM) for AMPOMATOR CLS IV Lead-Making Machines
- [409-5878](#) AMPOMATOR CLS IV+ Lead-Making Machine 356500-[ ]
- [409-10027](#) Stripping Modules 1490500 and 1490502
- [409-10029](#) Stripping Modules 1490501 and 1490503
- [409-10047](#) AMP-3K Terminating Machines 1725950

## 2.6. Manuals

Manual [402-40](#) is available upon request and can be used as a guide in soldering. This manual provides information on various flux types and characteristics along with the commercial designation and flux removal procedures. A checklist is attached to the manual as a guide for information on soldering problems.

### 3. REQUIREMENTS

#### 3.1. Storage

##### A. Ultraviolet Light

Prolonged exposure to ultraviolet light may deteriorate the chemical composition used in the housing material.

##### B. Reel Storage

When using reeled contacts, store coil wound reels horizontally and traverse wound reels vertically.

##### C. Shelf Life

Each connector is packaged and shipped in an individual antistatic tube container or tape and reel. To prevent damage to the housings and contact solder tines, the connectors should remain in the container until ready for installation. Also, to prevent possible storage contamination and ensure maximum solderability, the connectors should be used on a first in, first out basis.

##### D. Chemical Exposure

Do not store contacts near any of the following chemicals as they may cause stress corrosion.

Alkalies	Ammonia	Citrates	Phosphates	Citrates	Sulfur Compounds
Amines	Carbonates	Nitrites	Sulfur Nitrites		Tartrates



**NOTE**

Where the above environmental conditions exist, phosphor-bronze contacts are recommended instead of brass if available.

#### 3.2. Wire

##### A. Wire Selection

The contacts will accept stranded wires ranging in size from 10 to 30 AWG. Wire insulation diameter shall have minimum and maximum dimensions according to the wire sizes indicated in Figure 2. Reasonable care shall be taken during the stripping operation to ensure the conductor is not nicked, scraped, or cut.



**NOTE**

Contacts accept stranded wire only. Not intended for solid wire.

##### B. Wire Preparation

The wire strip length shall be according to the wire sizes as indicated in Figure 2.

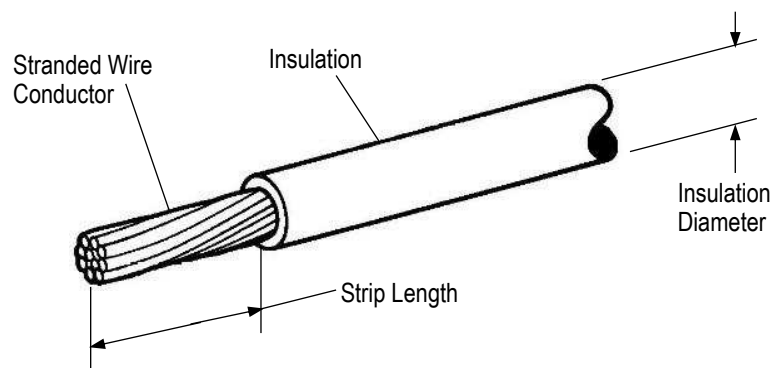

**NOTE:** Not to Scale.

Figure 2 (cont'd)

**AUTOMATIC MACHINE WIRE CRIMP DIMENSIONS**

WIRE			WIRE BARREL		INSULATION BARREL CRIMP WIDTH
SIZE (AWG)	INSULATION DIAMETER RANGE	STRIP LENGTH ±0.38 [.015]	CRIMP HEIGHT ±0.05 [.002]	CRIMP WIDTH	
30	0.81 to 1.45 [.032 to .057]	4.06 [.160]	0.71 [.028]	1.40 [.055]	2.29 [.090]
28			0.71 [.028]		
26			0.76 [.030]		
24	1.02 to 2.54 [.040 to .100]	4.37 [.172]	0.96 [.038]	1.78 [.070]	2.54△ [.100]
22			1.02 [.040]		
20			1.09 [.043]		
18			1.22 [.048]		
20	1.52 to 3.30 [.060 to .130]	4.37 [.172]	1.19 [.047]	2.29 [.090]	3.30 [.130]
18			1.32 [.052]		
16			1.50 [.059]		
14			1.75 [.069]		
20	3.30 to 5.08 [.130 to .200]	4.37 [.172]	1.19 [.047]	2.29 [.090]	5.08 [.200]
18			1.32 [.052]		
16			1.50 [.059]		
14			1.75 [.069]		
2 @ 18			1.60 [.063]		
18	3.30 to 5.08 [.130 to .200]	4.37 [.172]	1.50 [.059]	2.29 [.090]	5.08 [.200]
16			1.68 [.066]		
14			1.93 [.076]		
12	5.08 [.200]	6.76	1.83 [.072]	3.56	---
10	Max.	[.266]	2.29 [.090]	[.140]	

**HAND TOOL WIRE CRIMP DIMENSIONS**

WIRE			WIRE BARREL		INSULATION BARREL CRIMP WIDTH
SIZE (AWG)	INSULATION DIAMETER RANGE	STRIP LENGTH ±0.38 [.015]	CRIMP HEIGHT ±0.05 [.002]	CRIMP WIDTH	
30	0.81 to 1.45 [.032 to .057]	4.06 [.160]	0.71 [.028]	1.40 [.055]	2.29 [.090]
28			0.71 [.028]		
26			0.71 [.028]		
24	1.02 to 2.54 [.040 to .100]	4.37 [.172]	1.02 [.040]	1.78 [.070]	2.54 [.100]
22			1.02 [.040]		
20			1.17 [.046]		
18			1.17 [.046]		

△For part numbers 770210-1 and 770211-1, insulation barrel crimp width should be 3.30 [.130].

Figure 2 (cont'd)

HAND TOOL WIRE CRIMP DIMENSIONS					
WIRE			WIRE BARREL		INSULATION BARREL CRIMP WIDTH
SIZE (AWG)	INSULATION DIAMETER RANGE	STRIP LENGTH $\pm 0.38$ [.015]	CRIMP HEIGHT $\pm 0.05$ [.002]	CRIMP WIDTH	
20	1.52 to 3.30 [.060 to .130]	4.37 [.172]	1.27 [.050]	2.29 [.090]	3.30 [.130]
18			1.27 [.050]		
16			1.60 [.063]		
14			1.60 [.063]		
20	3.30 to 5.08 [.130 to .200]	4.37 [.172]	1.24 [.049]	2.29 [.090]	5.08 [.200]
18			1.24 [.049]		
16			1.60 [.063]		
14			1.60 [.063]		
12	5.08 [.200] Max.	6.76 [.266]	2.11 [.083]	3.56 [.140]	---
10			2.44 [.096]		

Figure 2 (end)

### 3.3. Crimped Contact Requirements

The contact shall be located in desired tooling and crimped according to the instructions packaged with that tooling. See Section 5, TOOLING, of this document for details on tooling options and instructional materials.



#### CAUTION

Wire insulation shall NOT be cut or broken during the crimping operation, nor shall the insulation be crimped into the contact wire barrel. Reasonable care should be taken by tooling operators to provide undamaged wire terminations.



#### NOTE

Wire stripping tool jaws may leave corrugated indentations on the surface of the wire insulation. This is especially severe with cross-linked polyethylene (high temperature) insulation. If these indentations occur at the location of the wire seal, leakage may result. Insulation surface within 8.89 mm from the tip of the contact must be smooth and free of indentations. See Figure 3.

#### A. Wire Barrel Crimp

The crimp applied to the wire portion of the contact is the most compressed area and is most critical in ensuring optimum electrical and mechanical performance of the crimped contact. The contact wire barrel crimp height must be within the dimension provided in Figure 2.

#### B. Effective Crimp Length

For optimum crimp effectiveness, the crimp must be within the area shown in Figure 3 and must meet the crimp dimensions provided in Figure 2. Effective crimp length shall be defined as that portion of the wire barrel, excluding bellmouth(s), fully formed by the crimping tool. Instructions for adjusting, repairing, and inspecting tools are packaged with the tools. See Section 5, TOOLING.

#### C. Bellmouths

Front and rear bellmouths shall be evident and conform to the dimensions given in Figure 3.

#### D. Cutoff Tabs

The cutoff tab shall be cut to the dimensions shown in Figure 3.

#### E. Burrs

The cutoff burr shall not exceed the dimensions shown in Figure 3.



High Retention Pin Contact

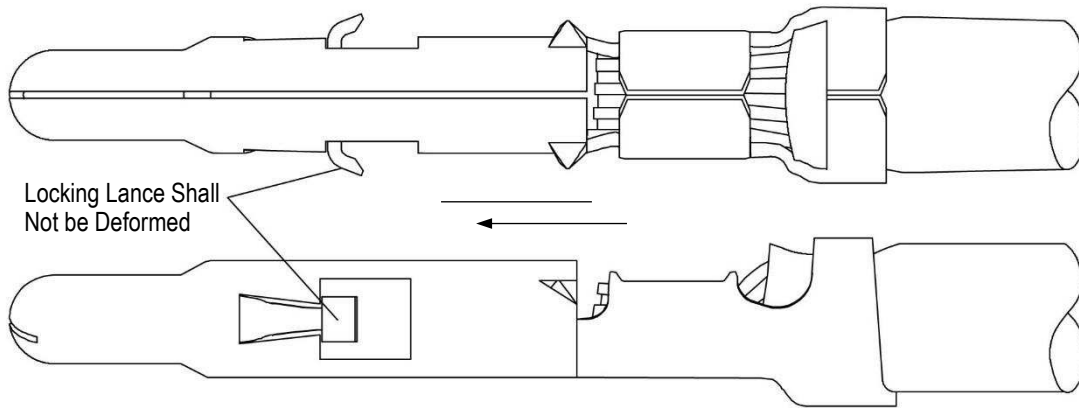

The Wire Barrel Seam Shall be Closed Adequately to Confine All Strands of the Wire. There Shall be No Loose Wire Strands or Wire Strands Embedded in the Outside of the Wire Barrel.

Wire Strands and Insulation Both Visible. Note: Large Diameter Insulation May Not be Visible When Crimping with Hand Tools.

Socket Contact

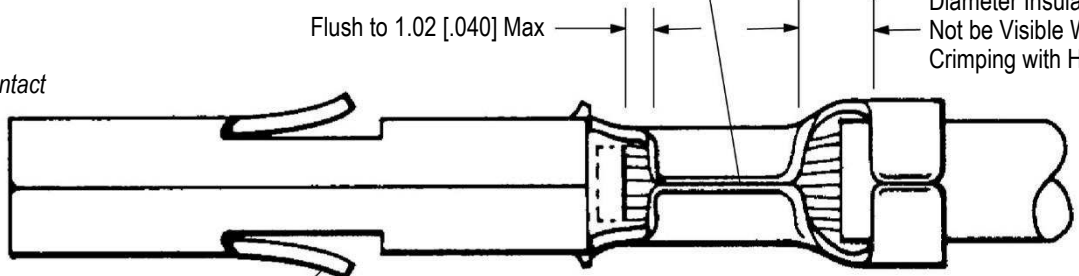

Locking Lance Shall Not be Deformed

Front Bellmouth  
 $0.25 \pm 0.00 / -0.25$   
 $[.010 \pm .000 / -.010]$

Rear Bellmouth  
 $0.13 [.005]$  to  
 $0.89 [.035]$

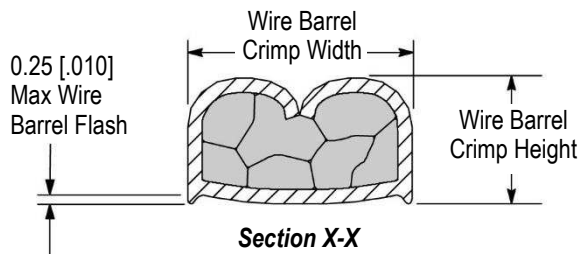
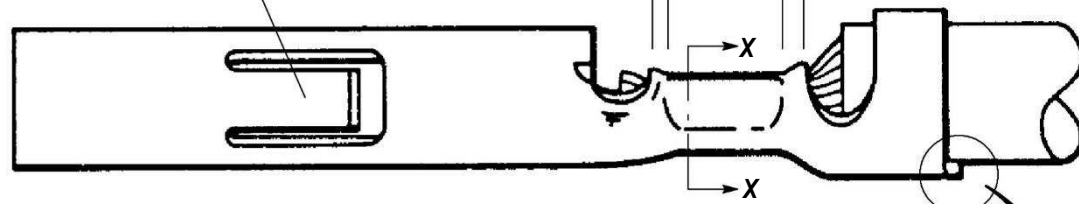

Cutoff Tab  
 $0.18 [.007]$  Max

No Burrs

Figure 3

**F. Wire Barrel Flash**

The wire barrel flash shall not exceed the dimensions shown in Figure 3, Section X-X.

**G. Insulation Barrel Crimp**

The insulation barrel shall grip the insulation firmly and legs of the insulation support crimp barrel may deform or cut into the insulation, but must not penetrate into the conductor. This product has two styles of insulation crimp. Most common is the F-crimp. For F-crimp style, the legs of the insulation barrel touch each other, and the crimp shall comply to width provided in Figure 2. For special cases, the overlap crimp or O-crimp is used. The overlap allows the legs of the insulation barrel overlap itself by at least the length of one material thickness. The O-crimp allows the legs of the insulation barrel to touch as shown. See Figure 4.

The smallest cable within the insulation range may have a gap between the insulation and the insulation barrel leg (max. of the difference of the diameter between the smallest and largest cable), however, must touch the insulation support barrel for at least a distance equal to half its circumference. See Figure 4.



Figure 4

**H. Wire Location**

The wire conductor and insulation must be visible in the transition area between the wire and insulation barrels as shown in Figure 3.

**I. Conductor Extension**

The conductor may extend beyond the wire barrel to the maximum shown in Figure 3.

**J. Wire Barrel Seam**

The wire barrel seam must be closed with no evidence of loose wire strands visible in the seam as shown in Figure 3.

**K. Twist and Roll**

There shall be no twist, roll, deformation or other damage to the mating portion of the crimped contact that will impair usage of the contact. See Figure 5.

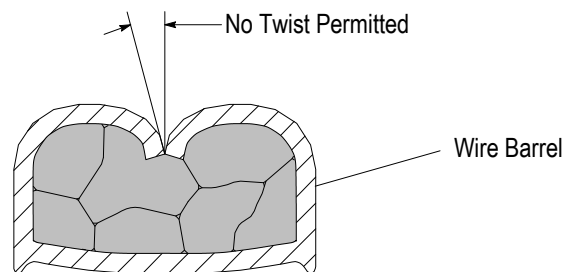

Figure 5

### L. Straightness/Alignment

The force applied during crimping may cause some bending between the crimped wire barrel and the mating portion of the contact. The axial concentricity of the crimped wire barrel shall fall into an area defined by a 4.19 mm [.165 in.] diameter circle whose center is the centerline of the contact. The axial concentricity of the crimped insulation barrel shall fall into an area defined by a 5.59 mm [.220 in.] diameter circle whose center is the centerline of the contact. Such deformation is acceptable within the limits provided in Figure 6.

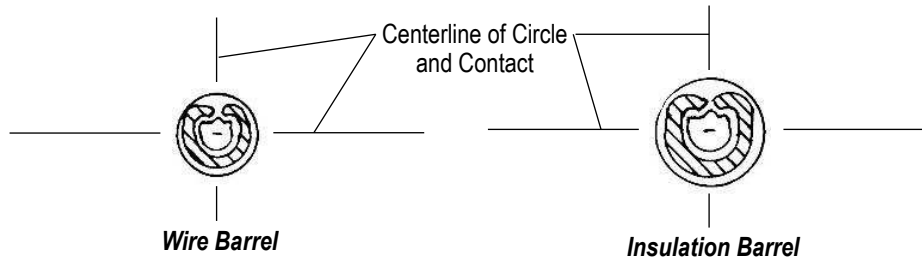

Figure 6

### 3.4. Housings

A connector assembly consists of a plug and a cap connector. A connector consists of a housing (plug or cap) with a specified number of crimp contacts (pin and/or socket). Mating connectors may be a plug and a cap, or a plug and a pc board header, so long as both have an identical number of circuits with a pin contact mating with a socket contact. Both the plug and cap housings have individually numbered cavity identification on the BACK (wire end), plus an identification rib on the SIDE indicating the No. 1 cavity. The housings feature polarizing cavities on the mating end and are intermateable with Universal MATE-N-LOK II connectors. The plug housing has two locking latches and the cap housing has two locking tabs. The housings are designed for free hanging or panel mounting applications (refer to Paragraph 3.9, Panel Cutout).

#### A. Assembly

Crimped pin and socket contacts shall be manually inserted in either the plug or cap housing, or they may be intermixed in each housing to provide multiple keying combinations. After inserting the terminal into the back of the housing, pull back lightly on the wire of the contact to make sure that the contact is locked in place. See Figure 7.



**NOTE**

*Insertion Tool 455830-1 (408-7984) is available for inserting contacts crimped to small wire sizes.*

#### B. Disassembly

Extraction Tool 1804030-1 (408-10049) is designed for removing pin and socket contacts from plug and cap housings. See Figure 7.

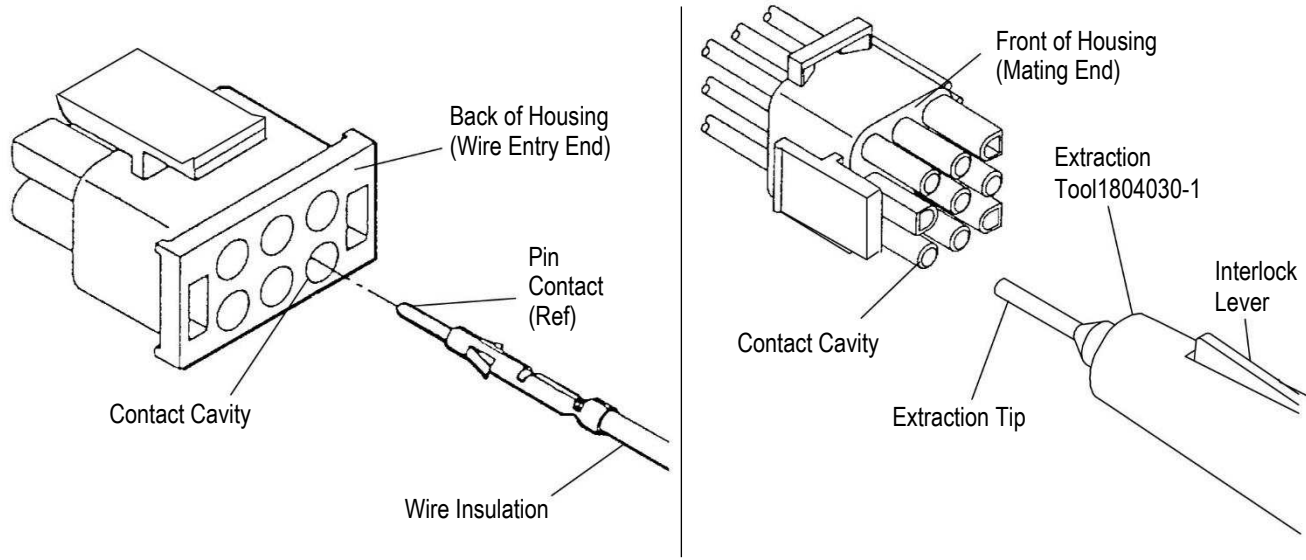

Figure 7

### C. Strain Relief and Wire Dress

If necessary, wires can be bundled together and supported with cable ties or similar device. Wires must not be stretched or confined in any way. Therefore, the wires must remain perpendicular to the connector and avoid an excessively sharp bend radius. The minimum distance for the cable tie, measured from the housing at the wire end of the connector to the cable tie is shown in Figure 8.

#### 3.5. Headers

The pc board headers are supplied preloaded with solder tail pin contacts or solder tail socket contacts. Vertical pin and socket headers are available in 2 through 15 circuits. Right-angle pin and socket headers are available in 2 through 8 circuits. All headers feature individually numbered cavity identification on the FRONT (mating end). The headers also feature polarizing cavities and locking tabs. The headers are designed to be mounted on a pc board (refer to Paragraph 3.10.C, Printed Circuit Board Layout).

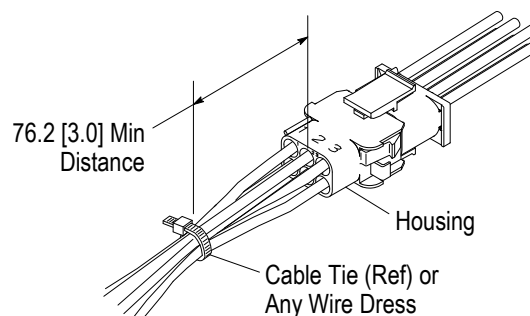

Figure 8

#### 3.6. Strain Relief Assembly

The strain relief assembly is designed to relieve the stress of the wires on the contacts. There are two strain relief versions (open and enclosed). The open version is available for 2 through 15 circuit plug housings. The enclosed version is available for 2 through 15 circuit plug or cap housings. The enclosed version features an attached insert for smaller wire bundles. Adapters are required when installing an enclosed strain relief assembly onto a cap housing. Two identical strain reliefs are inserted into slots in the back of the connector (or adapter) and are secured together with two No. 6 pan head self-tapping screws. See Figure 9.

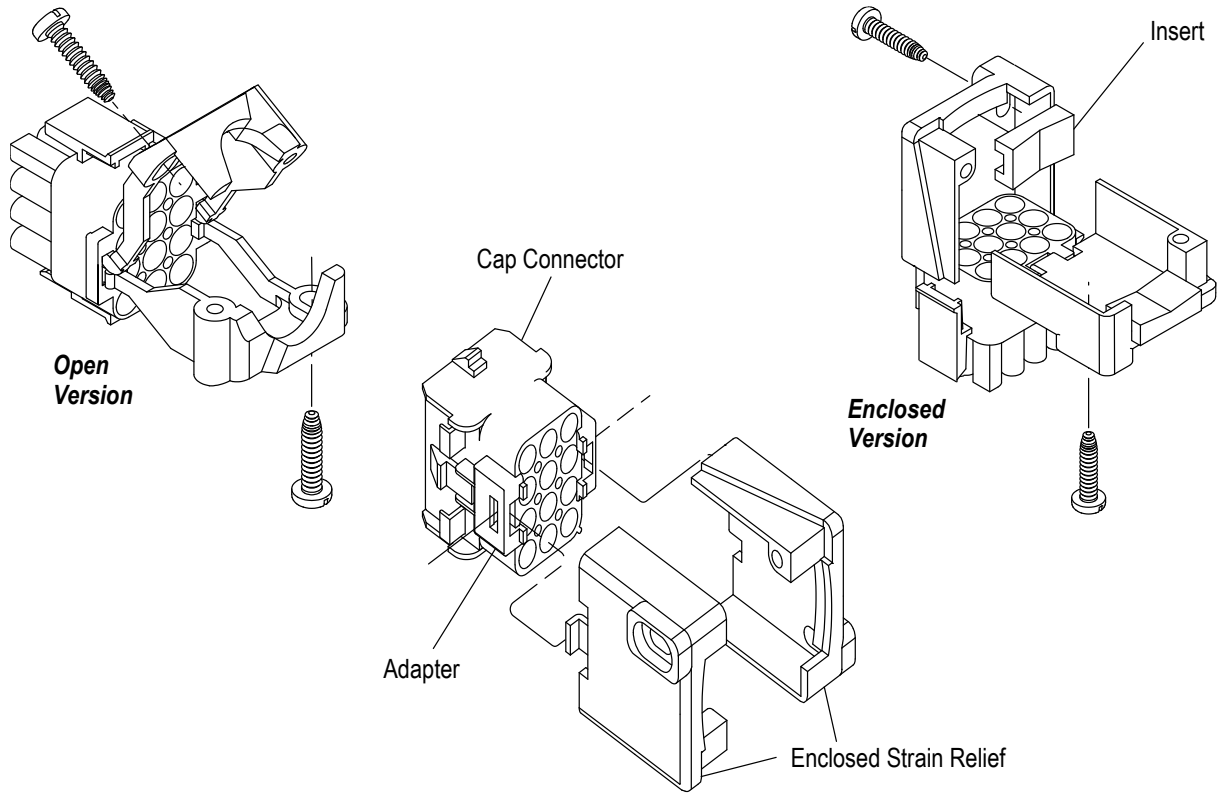

Figure 9

### 3.7. Keying Plugs

Keying plugs provide additional polarization for the connectors. The keying plug may be inserted into the front of the plug or the cap connector. See Figure 10.

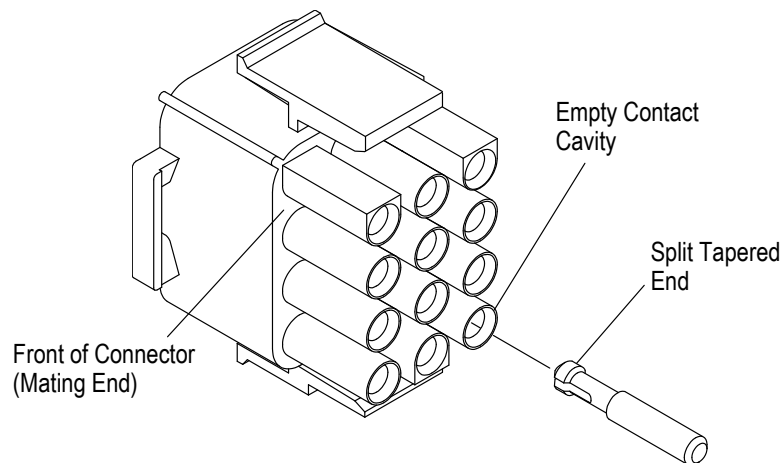

Figure 10

### 3.8. Test Connectors

Plug and cap test connectors mate with respective assembled plug and cap connectors and headers to test the electrical circuit. The test connectors are preloaded with spring loaded contacts that will mate with pin or socket contacts in the connector. The 2.13 mm [.084 in.] dia pin that extends out the BACK of the housing will accept Universal MATE-N-LOK socket contacts. See Figure 11.

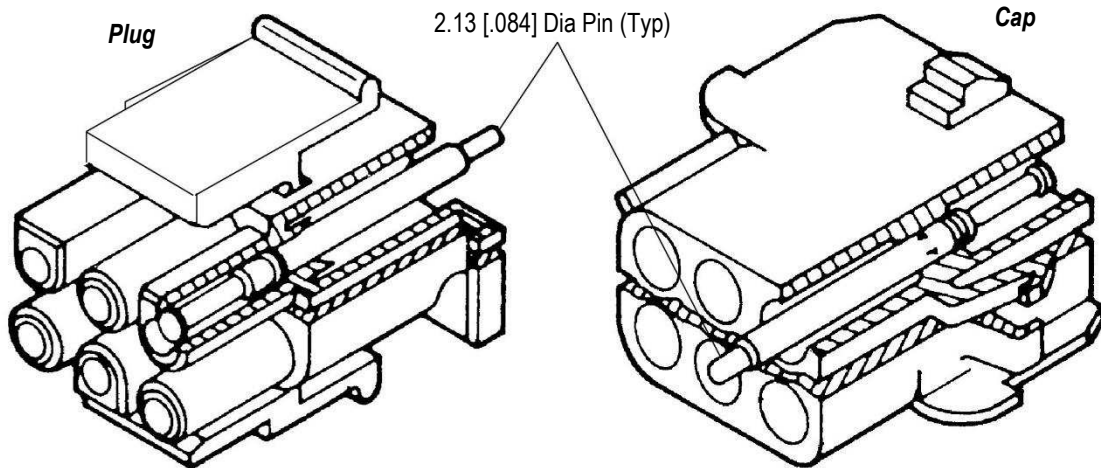

Figure 11



**NOTE**

*Test connectors have a 5 ampere maximum current rating per circuit.*

### 3.9. Optional TPA Devices

An optional TPA device is available for the plug housing and cap housing. Refer to [408-143222](#) for installation requirements and instructions.

The TPA device must be installed onto the wire end of the housing so that the latches are secure as described in [408-143140](#). If not fully latched, this indicates that one or more contacts has not been fully inserted.

### 3.10. Panel Cutout

Cap connector panel mounting cutouts shall be as indicated in Figure 12. (No mounting hardware is required.) The cap housing features flexible mounting latches for insertion into the panel. Push the cap connector through the panel - in the same direction as the cutout was made - until it snaps in place.

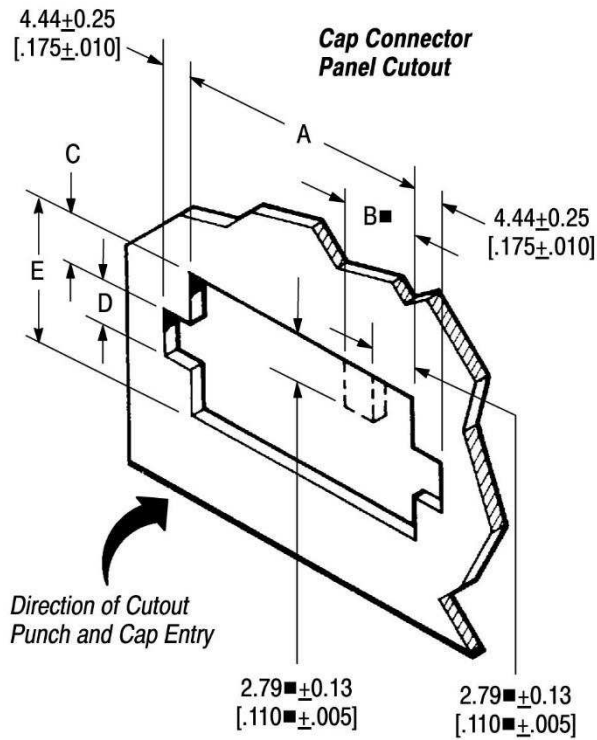

NUMBER OF CIRCUIT POSITIONS	DIMENSIONS				
	A ±0.13 [.005]	B■ ±0.25 [.010]	C ±0.25 [.010]	D ±0.25 [.010]	E ±0.13 [.005]
2	14.35 [.565]	6.35 [.250]	2.41 [.095]	8.64 [.340]	13.46 [.530]
3	20.70 [.815]				
4	27.05 [1.065]				
6	14.35 [.565]	8.89 [.350]	6.98 [.275]	12.19 [.480]	26.16 [1.030]
9	20.70 [.815]				
12	27.05 [1.065]				
15	33.40 [1.315]	8.89 [.350]			

■ Optional panel cutout dimensions for cap and panel polarization.

Panel Thickness - .762 [.030] to 2.286 [.090]

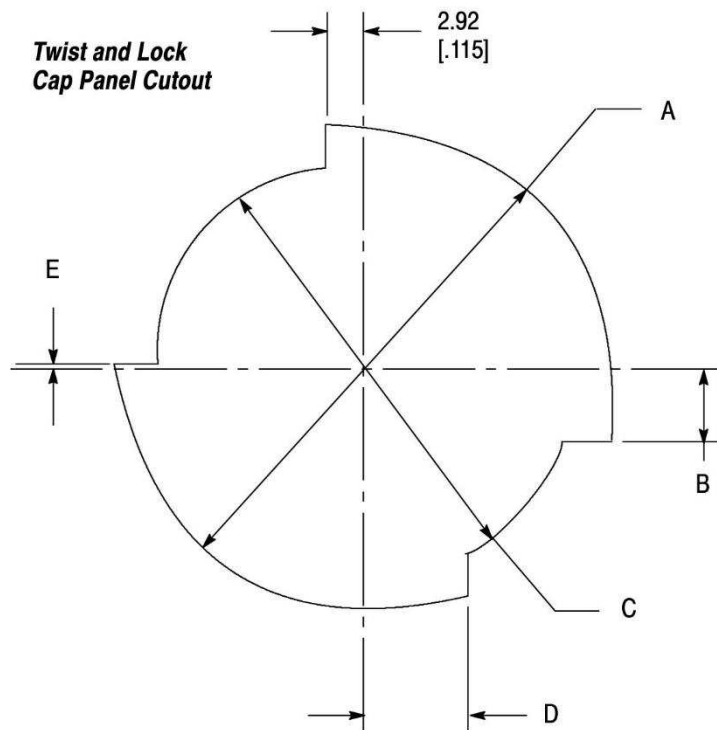

DIMENSION	POSITION SIZE	
	6 and 9	12
"A"	34.67 [1.365]	40.13 [1.580]
"B"	4.70 [.185]	6.15 [.242]
"C"	29.08 [1.145]	34.54 [1.360]
"D"	7.37 [.290]	8.08 [.318]
"E"	0.25 [.010]	1.98 [.078]

Figure 12

The Twist and Lock cap housing features a round helix for insertion into the panel. Refer to the panel cutout dimensions as shown in Figure 12.

The Twist and Lock panel cutout is polarized to ensure proper installation of the connector. Align the pin 1 indicator rib with the short side polarization opening of the panel and push the cap connector through the panel. Twist the connector clockwise until firmly seated. The panel thickness may vary between 0.76 and 2.29 mm [.030 and .090 in.]. In order to prevent foam leakage, the maximum amount of “gap” between the connector flange and the panel is 0.25 mm [.010 in.]. Refer to Figure 13.

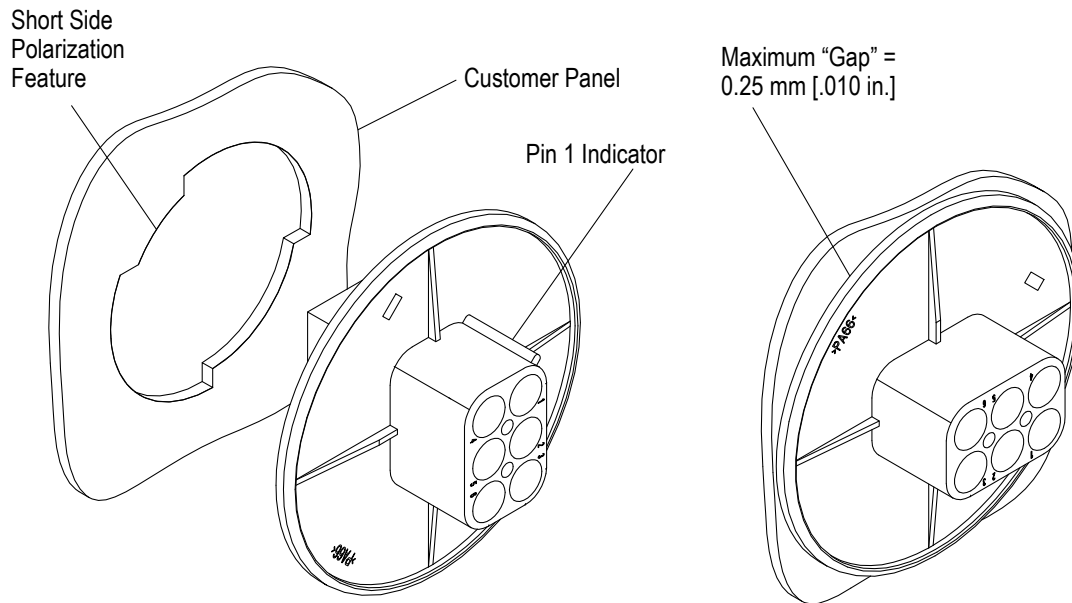

Figure 13

### 3.11. PC Board

#### A. Material and Thickness

1. Board material will be glass epoxy (FR-4, G-10).
2. The connector headers can be installed on pc boards up to 1.57 mm [.062 in.] thick for standard tails, and 3.18 mm [.125 in.] for long tails. Board thickness may vary depending upon the application. Contact the Product Information Center or the Tooling Assistance Center number listed at the bottom of page 1 for suitability of other board materials or thicknesses.

#### B. Tolerance

Maximum allowable bow of the pc board shall be 0.25 mm [.010 in.] over the length of the socket.

#### C. PC Board Layout

The mounting and contact holes in the pc board must be precisely located to ensure proper placement and optimum performance of the connector header. Design the pc board using the dimensions provided in Figure 14. The layout shows the top (component) side of the board.



#### NOTE

Figure 14 represents a typical pc board layout for this product. For dimensions and hole pattern layout for specific product, obtain the appropriate customer drawing through your Tyco Electronics Representative or refer to the telephone numbers at the bottom of page 1.



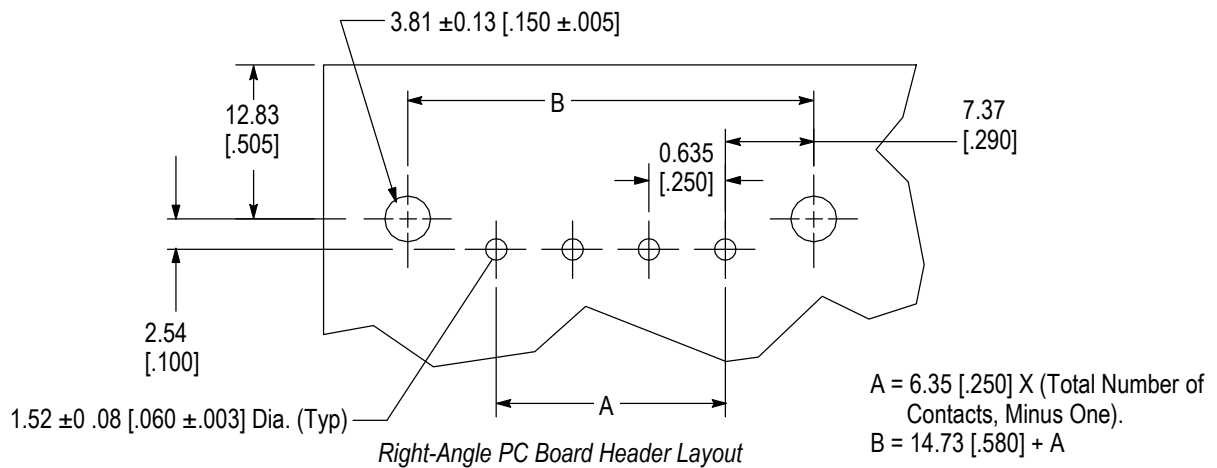
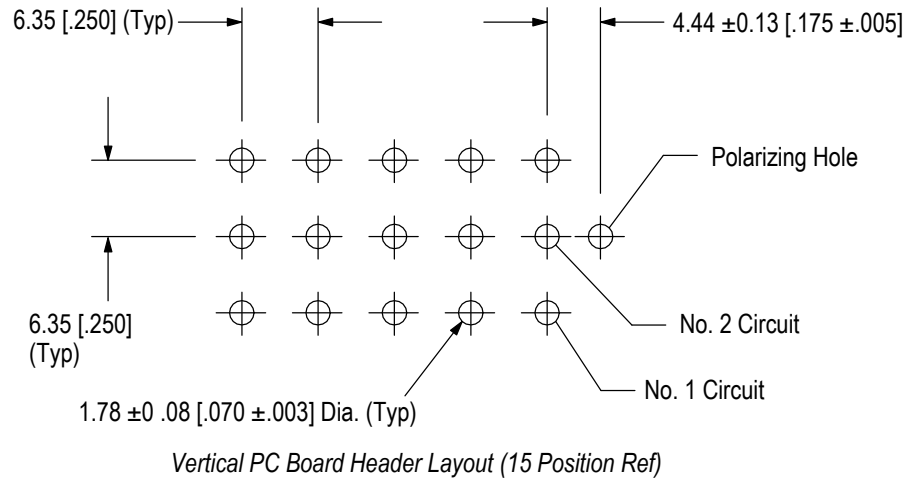

Figure 14

### 3.12. Contact Hole Configuration

The contact holes in the pc board must be prepared as specified in Figure 15.

**NOTE:** The drilled hole diameter must be sized so that the diameter of the finished hole after plating meets the dimensions as shown.

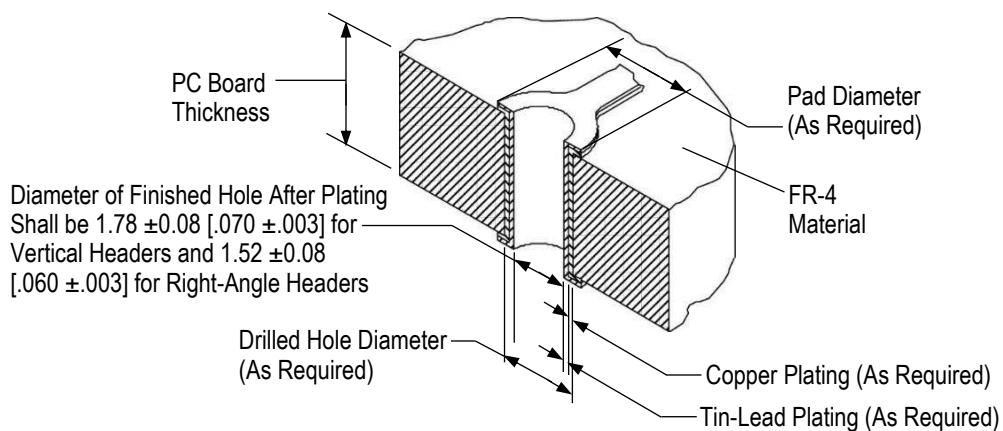

Figure 15

### 3.13. Soldering

#### A. Soldering Guidelines

Universal MATE-N-LOK Connector Headers can be soldered using wave or equivalent soldering techniques. The temperatures and exposure time shall be within the ranges specified in Figure 16. We recommend using SN60 or SN62 solder for these socket assemblies.

SOLDERING PROCESS	TEMPERATURE	TIME (At Max Temperature)
Wave	260°C [500°F] (Wave Temperature)	5 Seconds

Figure 6



#### NOTE

Manual 402-40 provides some guidelines for establishing soldering practices. Refer to Paragraph 2.6, Manuals.

#### B. Fluxing

The contact solder tines must be fluxed prior to soldering with a mildly active, rosin base flux. Selection of the flux will depend on the type of pc board and other components mounted on the board. Additionally, the flux must be compatible with the wave solder line, manufacturing, health, and safety requirements. Call the Product Information number at the bottom of page 1 for consideration of other types of flux. Some fluxes that are compatible with these sockets are provided in Figure 17.

FLUX TYPE	ACTIVITY	RESIDUE	COMMERCIAL DESIGNATION	
			ALPHA	KESTER
Type RMA (Mildly Activated)	Mild	Noncorrosive	611	185/197
Center (Activated)	Medium	May be Corrosive	711, 809, 811	1544, 1545, 1547

Figure 7

#### C. Cleaning

After soldering, removal of fluxes, residues, and activators is necessary. Consult with the supplier of the solder and flux for recommended cleaning solvents. The following is a listing of common cleaning solvents that will not affect the sockets. The sockets will be unaffected by any of these solvents for 5 minutes at room temperature.

Cleaners must be free of dissolved flux and other contaminants. We recommend cleaning with the pc board on its edge. If using an aqueous cleaner, we recommend standard equipment such as a soak-tank or an automatic in-line machine. See Figure 18.

CLEANER		TIME (Minutes)	TEMPERATURE (Max)
NAME	TYPE		
ALPHA 2110	Aqueous	1	132°C [270°F]
BIOACT EC-7	Solvent	5	100°C [212°F]
Butyl CARBITOL	Solvent	1	Ambient Room
Isopropyl Alcohol	Solvent	5	100°C [212°F]
KESTER 5778	Aqueous		
KESTER 5779	Aqueous		
LONCOTERGE 520	Aqueous		
LONCOTERGE 530	Aqueous		
Terpene	Solvent		

Figure 18

ALPHA, BIOACT, CARBITOL, LONCOTERGE, and KESTER are trademarks of their respective owners.

**DANGER**

Consideration must be given to toxicity and other safety requirements recommended by the solvent manufacturer. Trichloroethylene and Methylene Chloride can be used with no harmful effect to the sockets; however, TE does not recommend them because of the harmful occupational and environmental effects. Both are carcinogenic (cancer-causing) and Trichloroethylene is harmful to the earth's ozone layer.

**NOTE**

If you have a particular solvent that is not listed, contact the Product Information number at the bottom of page 1.

**D. Drying**

When drying clean assemblies and pc boards, air drying of is recommended. Temperature for the sockets should not exceed 105°C [221°F] for a period of five minutes with no degradation to the connector components. Degradation of the sockets could result from extreme temperatures.

**E. Checking Installed Socket**

All solder joints should conform to those specified in Test Specification 109-11.

**3.14. Repair/Replacement**

Damaged crimped contacts or housings must be removed, discarded, and replaced with new components. Use an extraction tool to remove individual contacts from connectors for replacement or for relocation to another housing cavity. Extraction Tool 318851-1 is used to extract contacts from the connectors.

**CAUTION**

If a damaged contact is evident before the contacts are inserted into the housing, cut the wire in back of the contact and re-terminate the wire end. If the contact or housing is damaged after insertion, remove the contact with the extraction tool and cut the wire in back of the contact and re-terminate wire end.

**CAUTION**

When removing connector headers from pc boards, reasonable care should be taken to remove the headers straight and in-line in relation to the pc boards. In free-hanging applications, the wires must be supported during removal to prevent excess strain on the contacts. Improper removal could result in damage to the wires, housing, contacts, or pc board.

**4. QUALIFICATION**

The Universal MATE-N-LOK Connectors are Listed by Underwriters Laboratories Inc. (UL) in File Number E28476, Certified to CSA International in File LR7189, and designed and tested to meet VDE 3980/continuous surveillance.

**5. TOOLING**

Tooling information for product part numbers is available from [www.te.com](http://www.te.com) or by calling the Product Information Center at the number at the bottom of page 1.

## 6. VISUAL AID

The illustration below shows a typical application of this product. This illustration should be used by production personnel to ensure a correctly applied product. Applications which DO NOT appear correct should be inspected using the information in the preceding pages of this specification and in the instructional material shipped with the product or tooling.

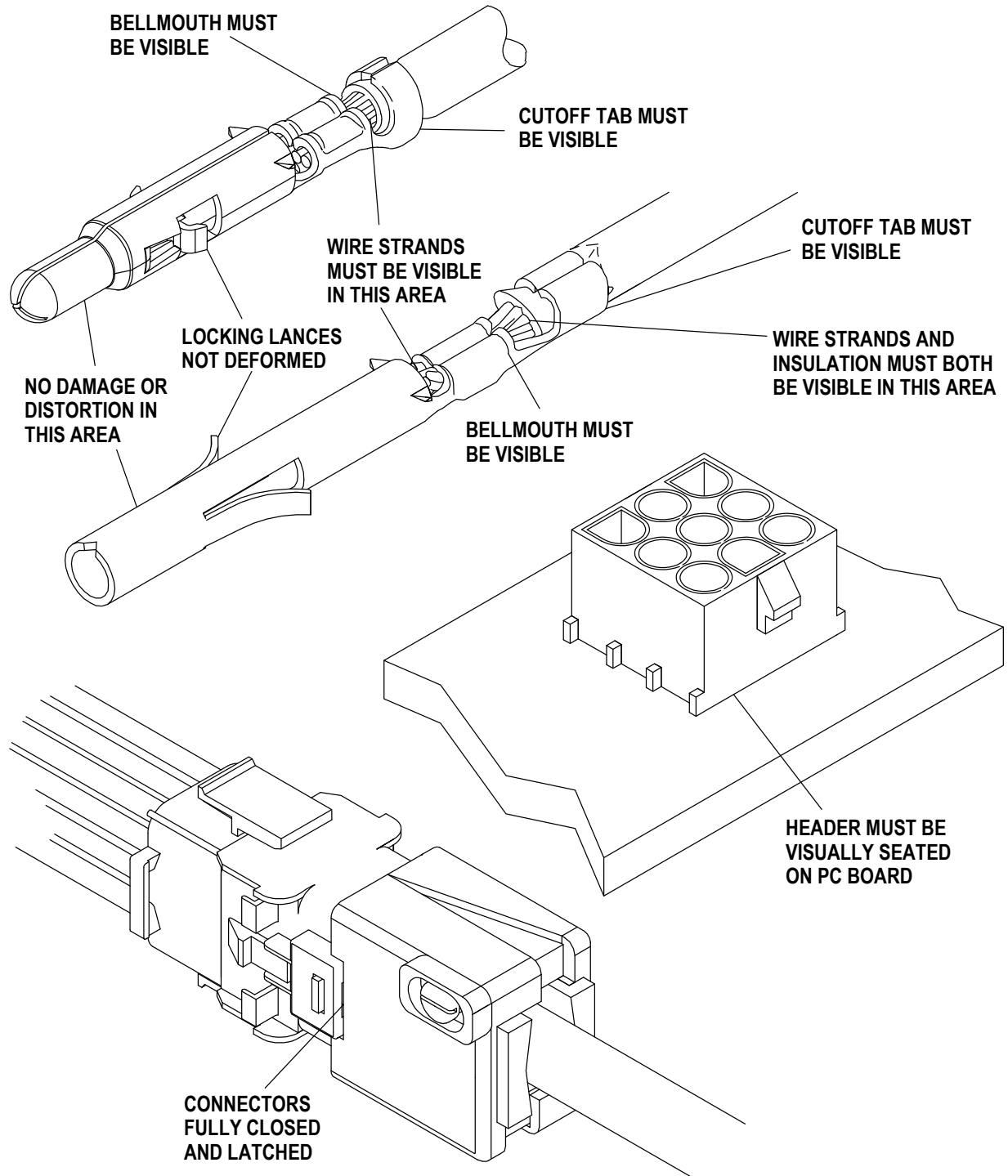

**FIGURE 20. VISUAL AID**