

LOC	DIST	REVISIONS				
CM	0	REV	DESCRIPTION	DATE	BY	APPROV
AP3	REVISED PER ECR-17-008392			26JUN2017	BW	KR

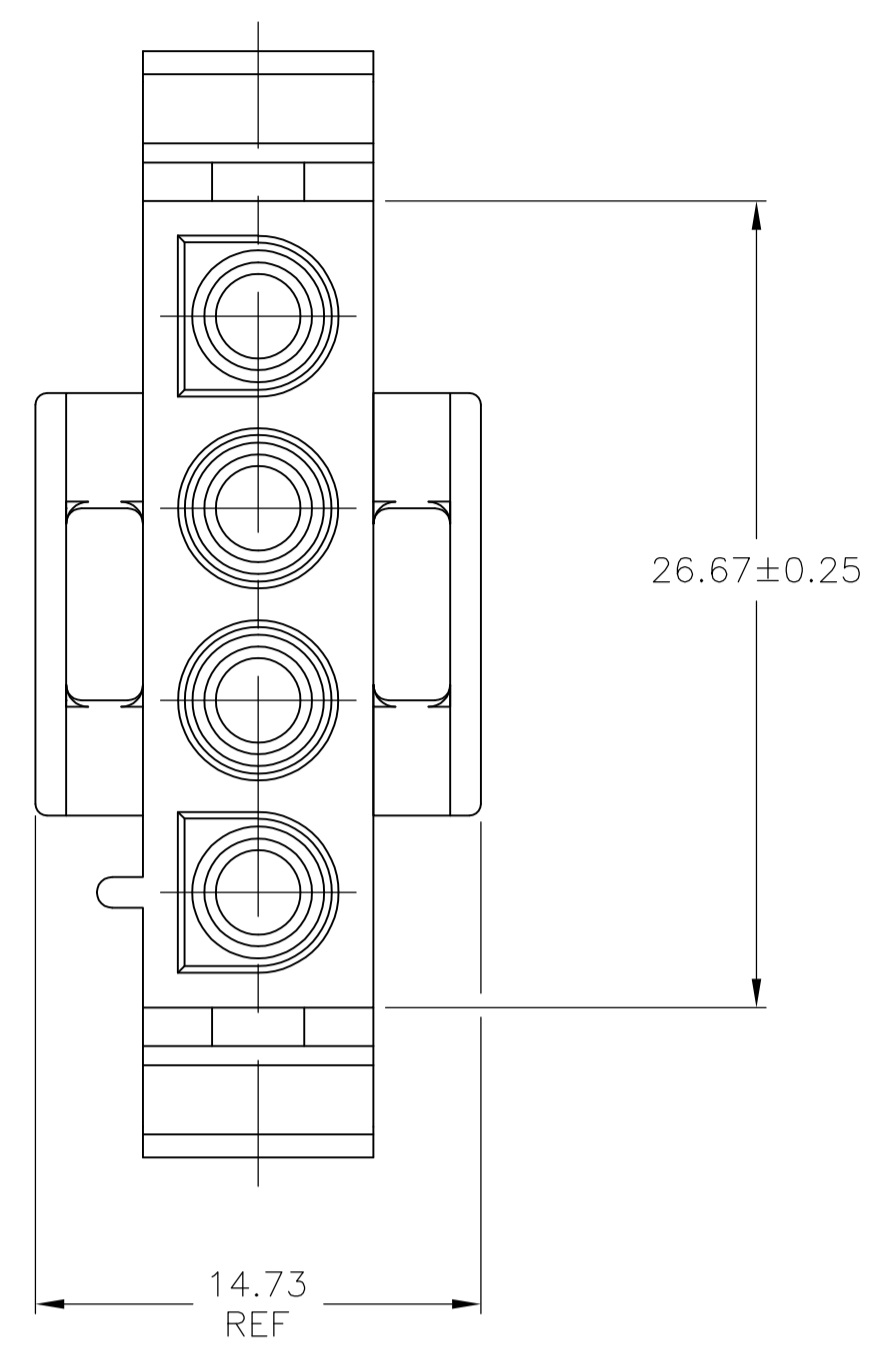

- NOTES:
- MATES WITH APPROPRIATE UNIVERSAL MATE-N-LOK™ CAP OR HEADER.
 - SMALL NICKS ARE PERMITTED ON THE CIRCUIT TOWERS WHICH COULD INCREASE THE INITIAL HOUSING MATING FORCE BY UP TO 4.4 NEWTONS [1.0 LBS]. NO INDIVIDUAL NICKED TOWER SHALL INCREASE THIS FORCE BY OVER 2.2 NEWTONS [.5 LBS].
 - DIMENSIONS SHOWN REPRESENT PRODUCT IN DRY, AS MOLDED, CONDITION. ADDITIONAL 2% GROWTH DUE TO SUBSEQUENT MOISTURE ABSORPTION MAY OCCUR AND SHOULD BE ACCOUNTED FOR.
- △ 4 FOUR RIBS EQUALLY SPACED, NO SPECIFIC ORIENTATION. NO RIBS OR SIX RIBS EQUALLY SPACED, NO SPECIFIC ORIENTATION, OPTIONAL.
- △ 5 UNDERWRITERS RECOGNIZED COMPONENT LOGO AND CSA CERTIFICATION LOGO TO BE LOCATED ONCE EACH ON SIDE OF HOUSING.
- △ 6 TRADEMARK LOCATION (AMP OR TE CONNECTIVITY).
- △ 7 MANUFACTURING LOCATION ID (OPTIONAL).
- △ 8 OBSOLETE PARTS: OBSOLETE CIS STREAMLINING PER D.RENAUD/D.SINISI

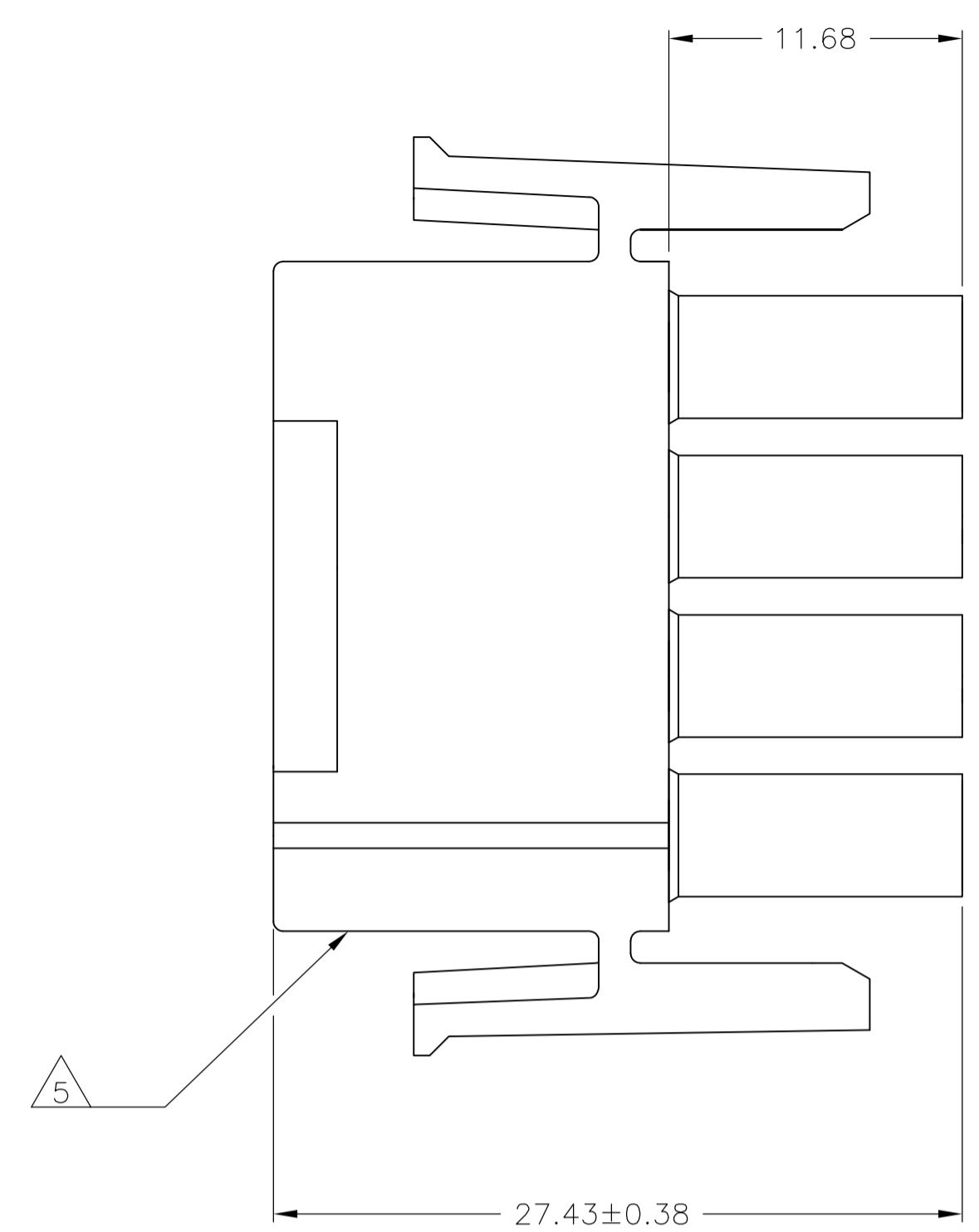
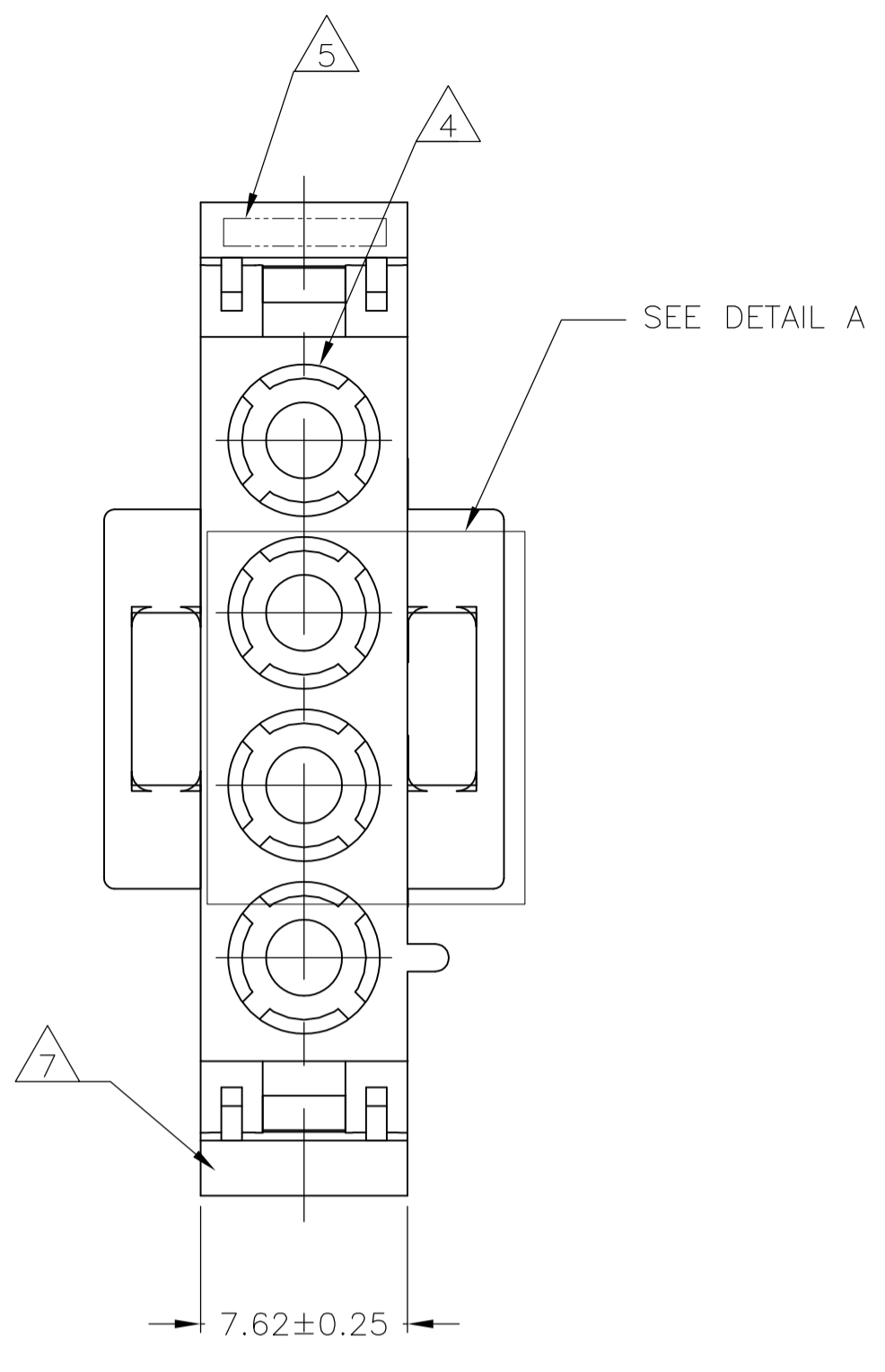
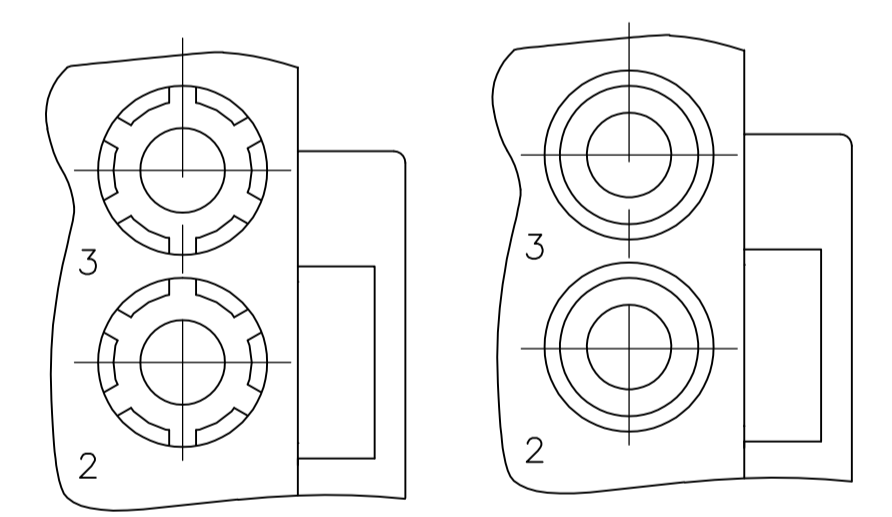
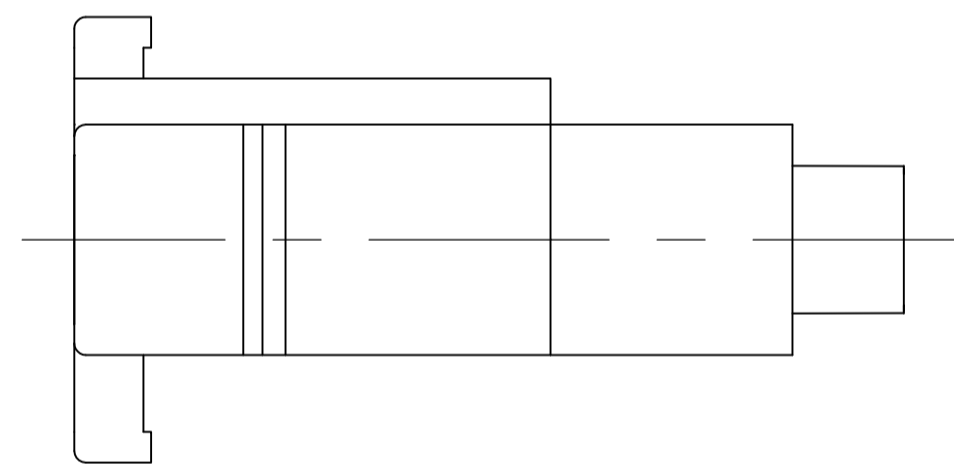

DETAIL A
OPTIONAL CONSTRUCTION

勝特力電材超市-龍山店 886-3-5773766
 勝特力電材超市-光復店 886-3-5729570
 勝特力電子(上海) 86-21-34970699
 勝特力電子(深圳) 86-755-83298787
<http://www.100y.com.tw>

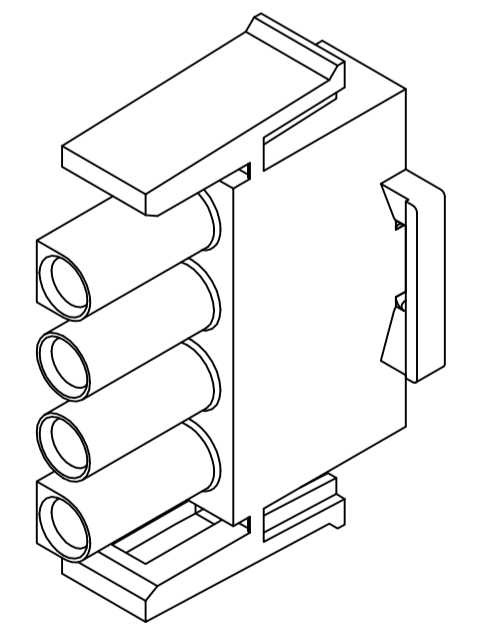

3-DIMENSIONAL MODEL
NTS

MM	IN
27.43	1.080
26.67	1.050
14.73	.580
11.68	.460
7.62	.300
0.38	.015
0.25	.010
0.13	.005

CONVERSION TABLE

Color	Part Number
BLACK	1-480702-9
GRAY	1-480702-8
BLUE	1-480702-6
GREEN	1-480702-5
YELLOW	1-480702-4
ORANGE	1-480702-3
RED	1-480702-2
BROWN	1-480702-1
NATURAL	1-480702-0
COLOR	PART NUMBER

△ 8 OBSOLETE

△ 8 SUPERSEDED BY 1-480700-0

△ 8 OBSOLETE

THIS DRAWING IS A CONTROLLED DOCUMENT.		DIN R VESTAL 08FEB95	STE TE Connectivity	
DIMENSIONS: mm		CHK R SWING 08FEB95	NAME PLUG, 4 CIRCUIT, UNIVERSAL MATE-N-LOK(TM)	
TOLERANCES UNLESS OTHERWISE SPECIFIED:		APPRO D SELF 08FEB95	PRODUCT SPEC	
0. PLC ± -		APPLICATION SPEC		
1. PLC ± -		SIZE		
2. PLC ± 0.13		CAGE CODE		
3. PLC ± -		DRAWING NO		
4. PLC ± -		RESTRICTED TO		
ANGLES ± 0°30'		A1 00779 480702		
MATERIAL NYLON, UL 94V-2	FINISH -	WEIGHT	SCALE 4:1	SHEET 1 OF 2
CUSTOMER DRAWING		REV AP3		

LOC	DIST	REVISIONS			
CM	0	REV	DESCRIPTION	DATE	DNW
		1	SEE SHEET 1		

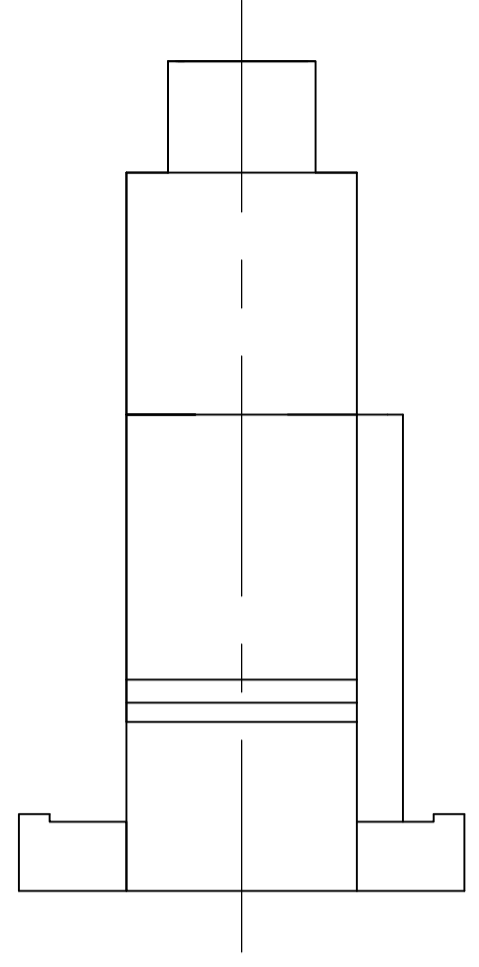

- NOTES:
1. STAMP NUMBERS 3.18 HIGH AT WIRE END OF HOUSING (12 POINT DAVID TYPE).
 2. CHARACTERS TO BE POSITIONED ON HOUSING TO BE READ FROM WIRE END ONLY.
 3. VIOLET, BLACK, BROWN AND BLUE COLORED BLOCKS TO BE STAMPED WITH WHITE CHARACTERS. ALL OTHER COLORED BLOCKS TO BE STAMPED WITH BLACK CHARACTERS.

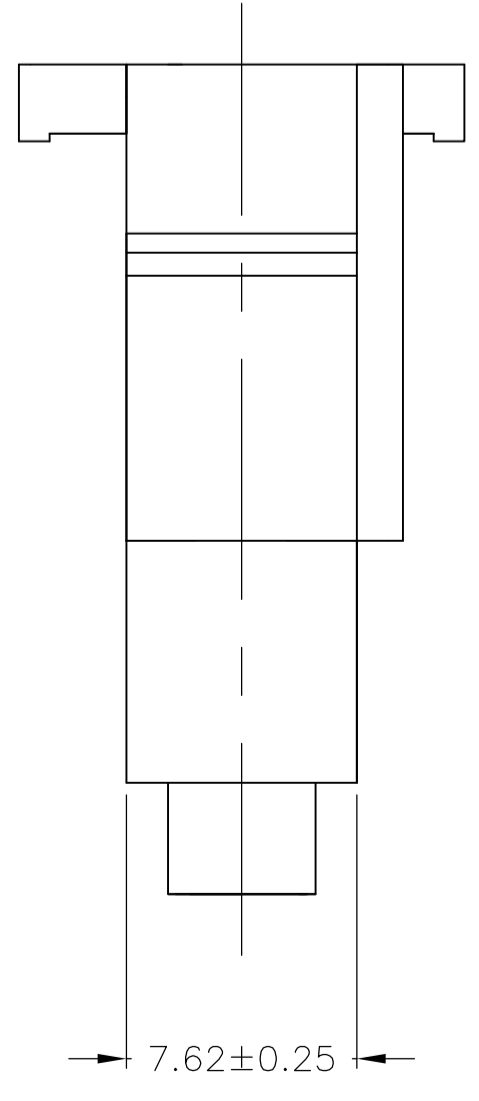
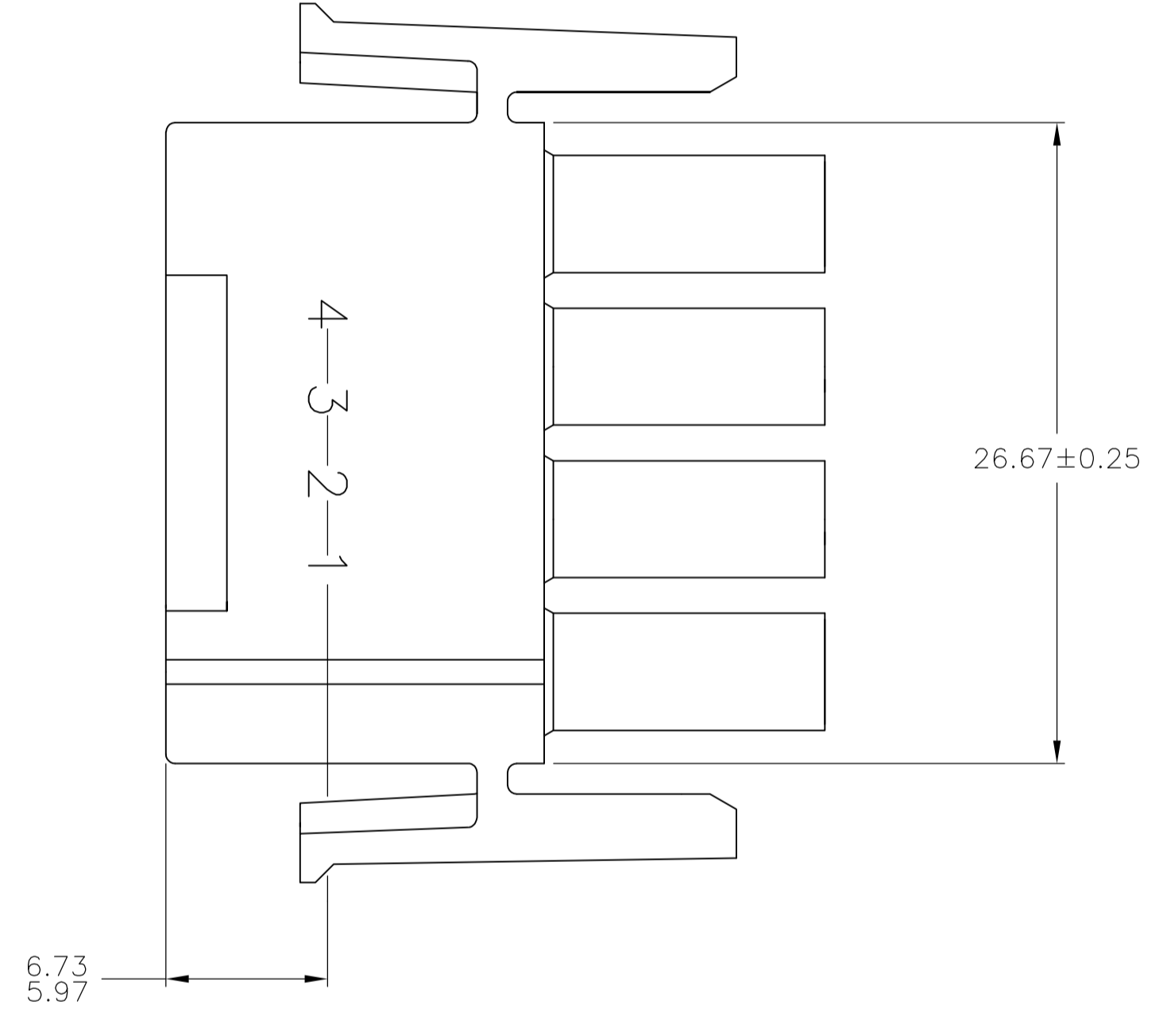
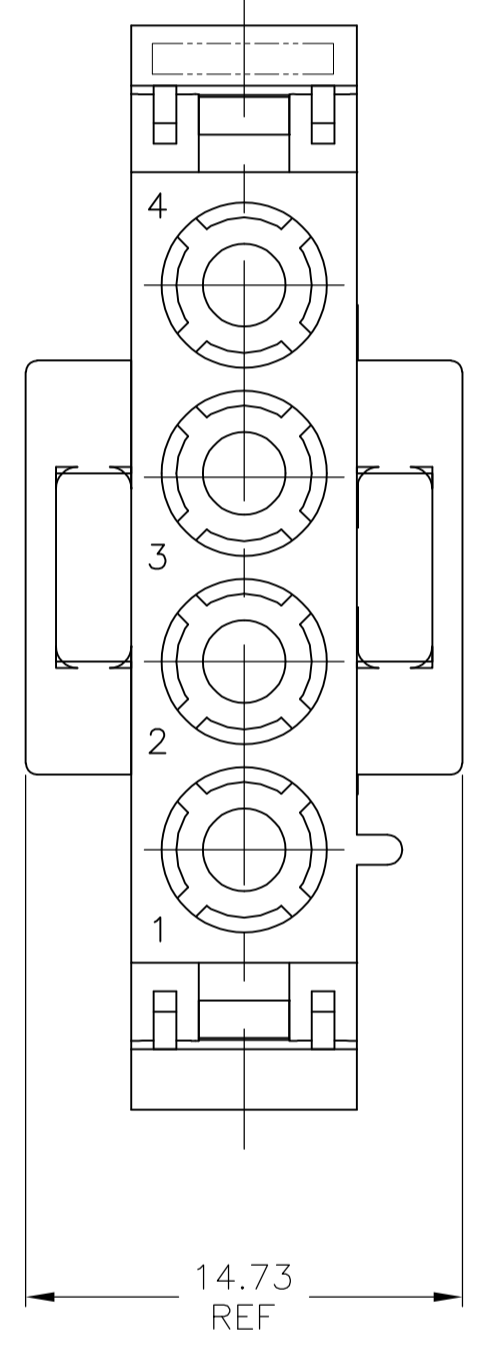
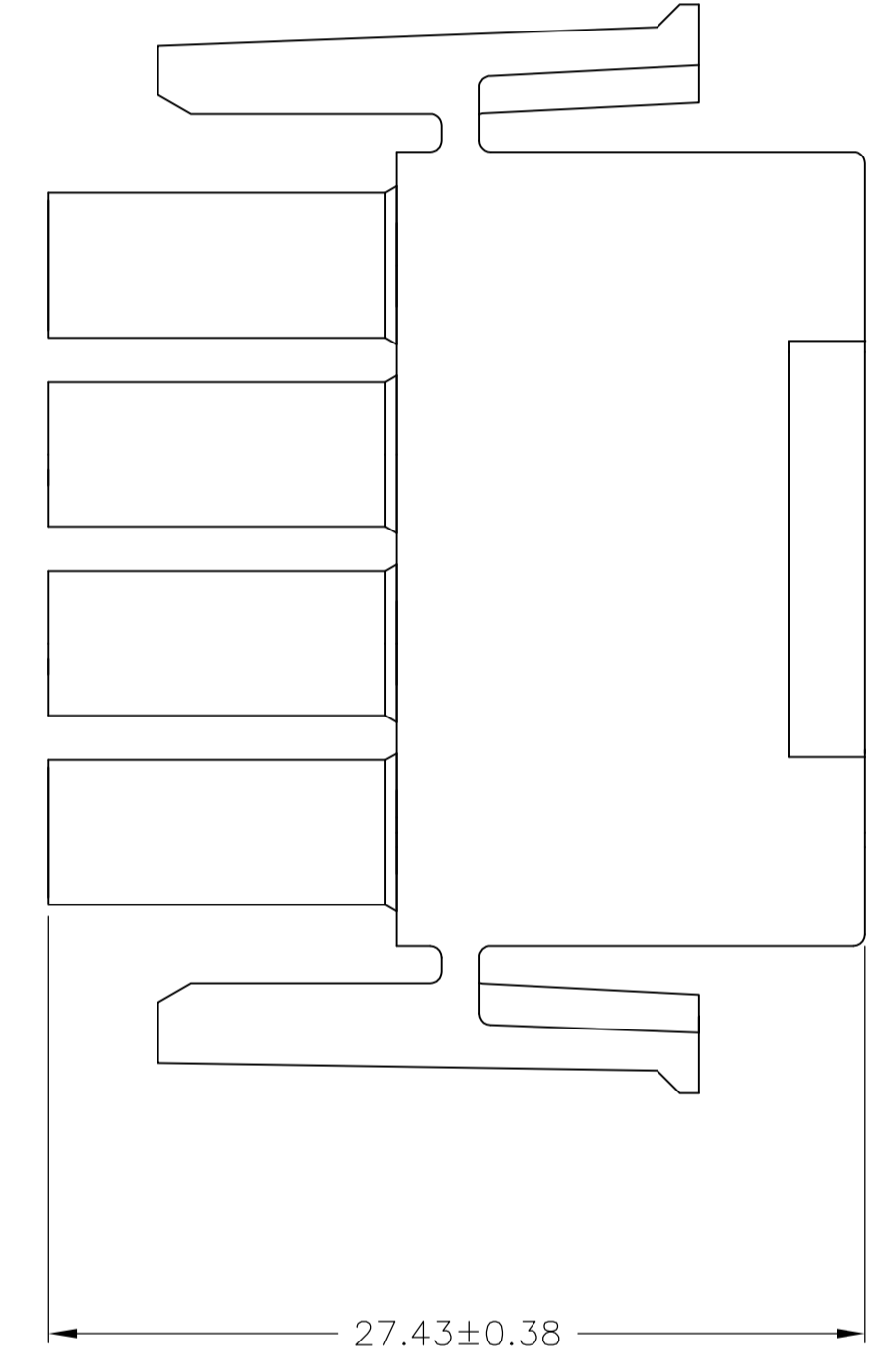

6.73	.265	-	-
5.97	.235	-	-
3.18	.125	27.43	1.080
0.38	.015	26.67	1.050
0.25	.010	14.73	.580
0.13	.005	7.62	.300
MM	IN	MM	IN

CONVERSION TABLE

NATURAL COLOR	2-480702-0
	PART NUMBER

THIS DRAWING IS A CONTROLLED DOCUMENT.

DIN R VESTAL 08FEB95	APPROVED	NAME	PLUG, 4 CIRCUIT, UNIVERSAL MATE-N-LOK(TM)
CHK R SWING 08FEB95	DATE	SIZE	A1
APPROVED D SELF 08FEB95	DESCRIPTION	CAGE CODE	00779
PRODUCT SPEC	APPLICATION SPEC	DRAWING NO	480702
WEIGHT	RESTRICTED TO	SCALE	4:1
MATERIAL NYLON, UL 94V-2	FINISH	SHEET	2 OF 2
		REV	AP3

CUSTOMER DRAWING