

STRIP FORM Bandware

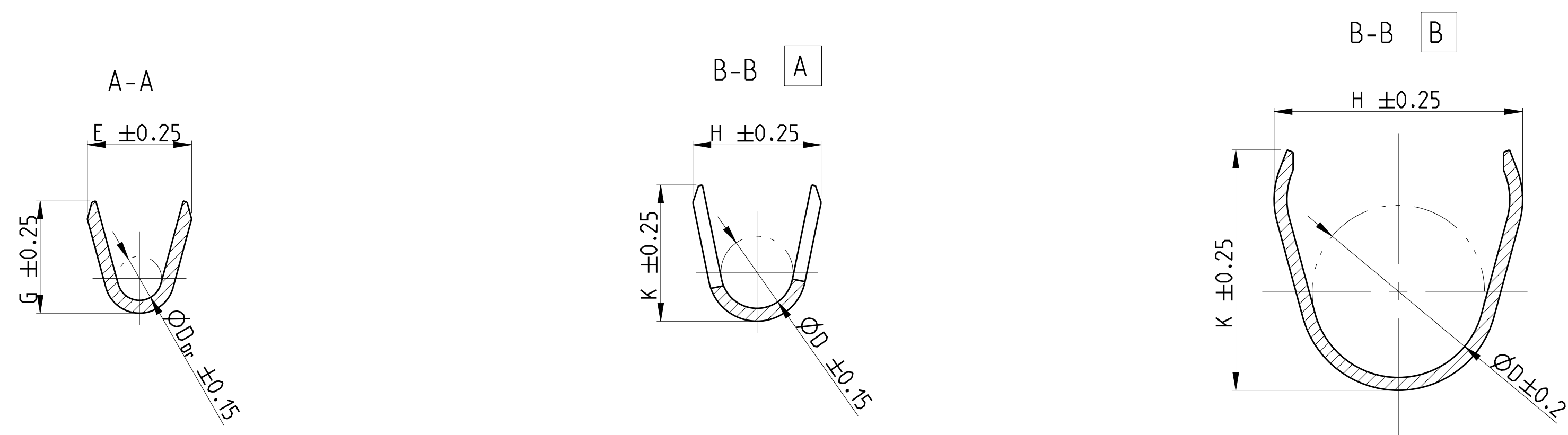

- 1 CONTACT AREA PRE SILVER MIN. 3µm
CANTILEVER SPRING PLAIN
Kontaktzone vorversilbert min. 3µm
Ueberfederer blank
- 2 CONTACT BODY NI-PLATING MIN. 0.5µm; CONTACT AREA PRE-GOLD MIN. 0.6µm
OVER NICKEL; CRIMP AREA PRE-TIN
CANTILEVER SPRING PLAIN
Kontaktkörper vernickelt min. 0.5µm; Kontaktzone vorvergoldet min. 0.6µm ueber Nickel
Crimpszone vorverzinkt; Ueberfederer blank
- 3 IN THIS AREA CRACK SHAPING AT THE SURFACE PERMISSIBLE
In diesem Bereich Rissbildung in der Oberflaeche zulassig
- 4 PRE-TIN MIN. 1µm; CANTILEVER SPRING PLAIN
vorverzinkt min. 1µm; Ueberfederer blank

- 5 AWG 12 TXL 828905-1 OR / oder 282536-1
AWG 12 GXL 638865-1
- 6 ATTENTION! CONSTRUCTION OF THE CONTACT CAVITY IN THE AREA OF THE SINGLE WIRE SEAL IS $\phi 6.4^{+0.1}_{-0.05}$
Achtung! Die Kammer ist im Bereich der Einzeldichtung auf $\phi 6.4^{+0.1}_{-0.05}$ auszuliegen
- 7 PUNCHED WITH VOLATILIZING STAMPING-OIL
Gestanz mit verfluechtigendem Stanzoeel

FLR-/FLK-WIRE FLR-/FLK-Leitung

DESIGN 1 Ausfuehrung 1

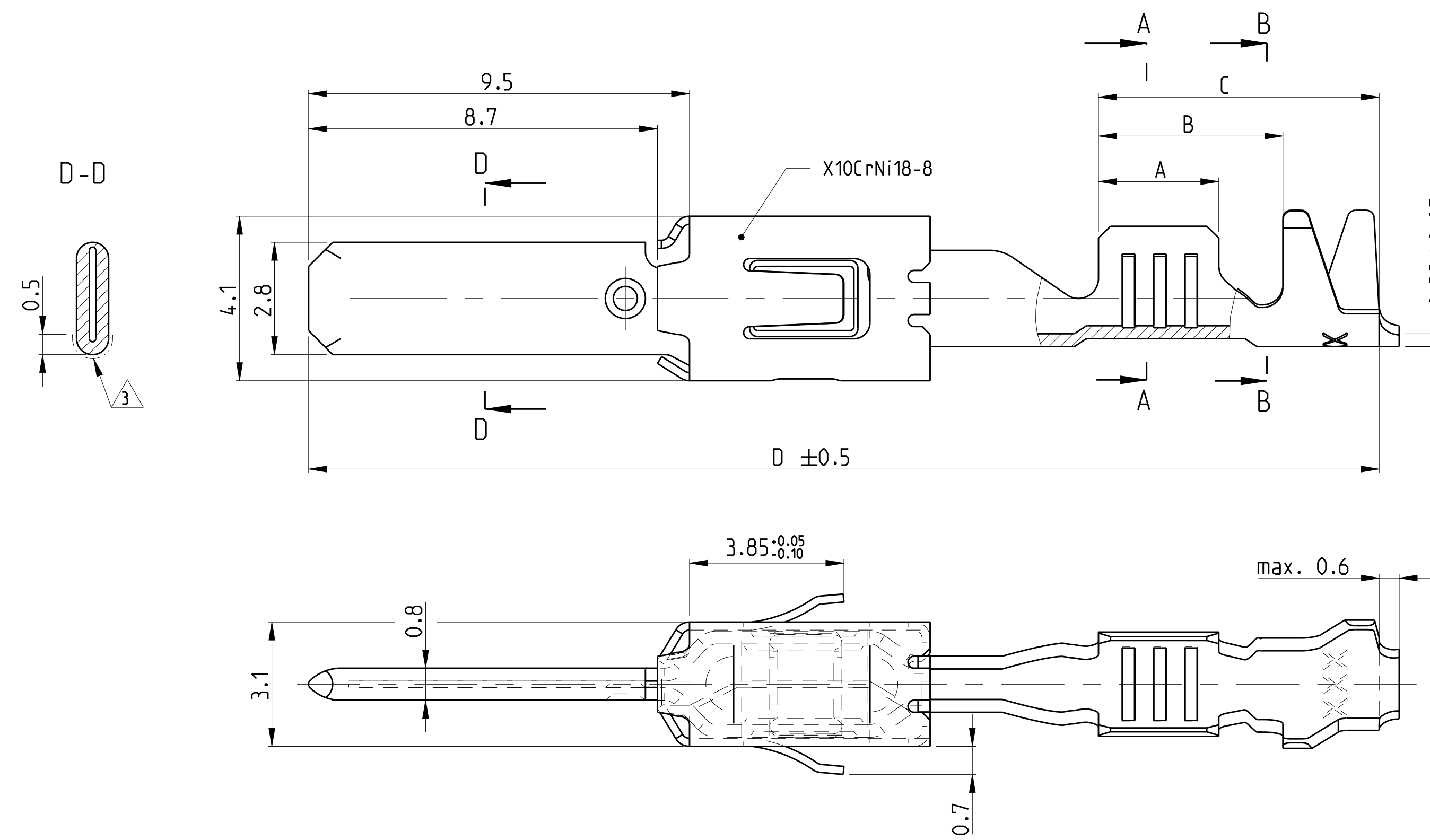

SINGLE WIRE SEAL Einzeldichtungssystem

DESIGN 4 Ausfuehrung 4

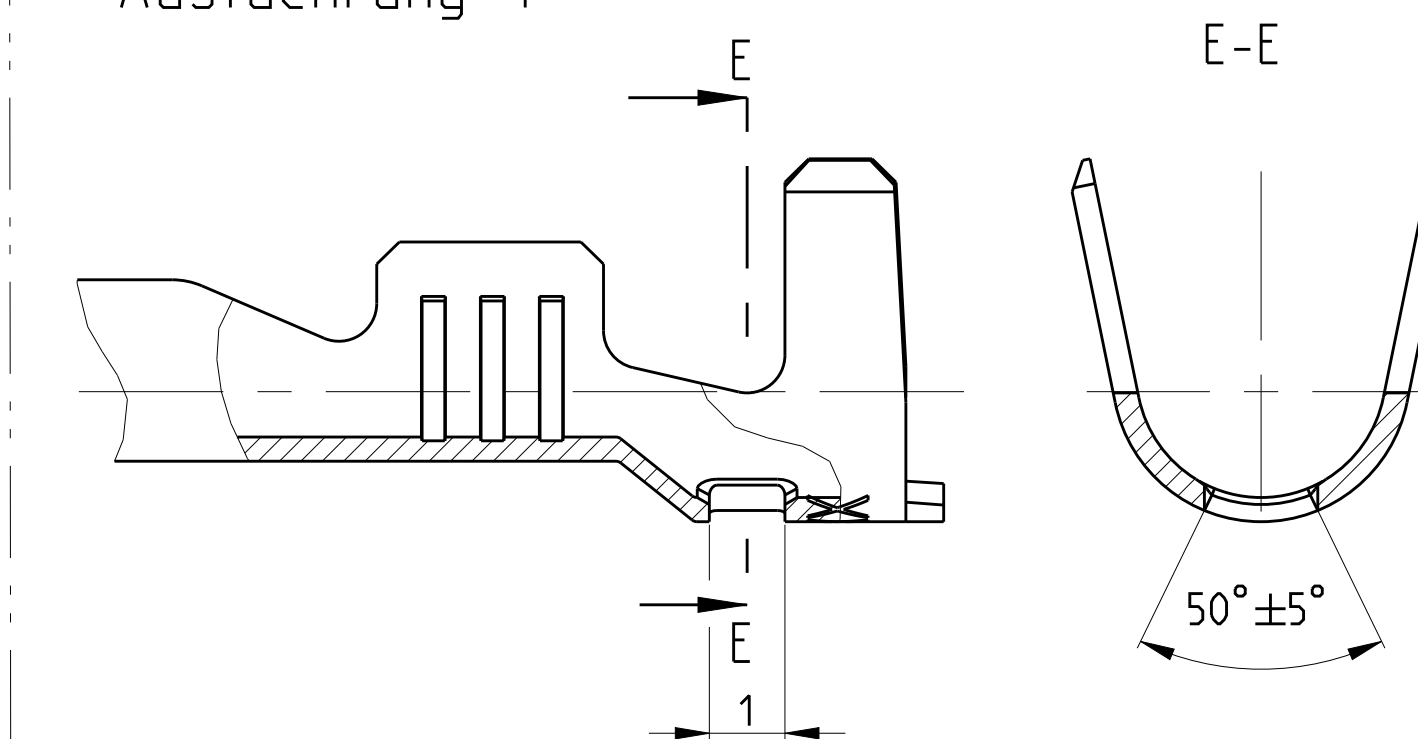

DESIGN 2 Ausfuehrung 2

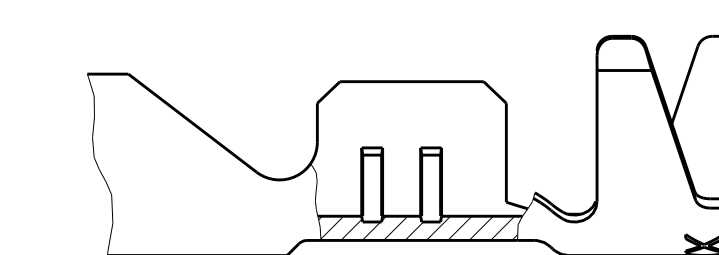

DESIGN 5 Ausfuehrung 5

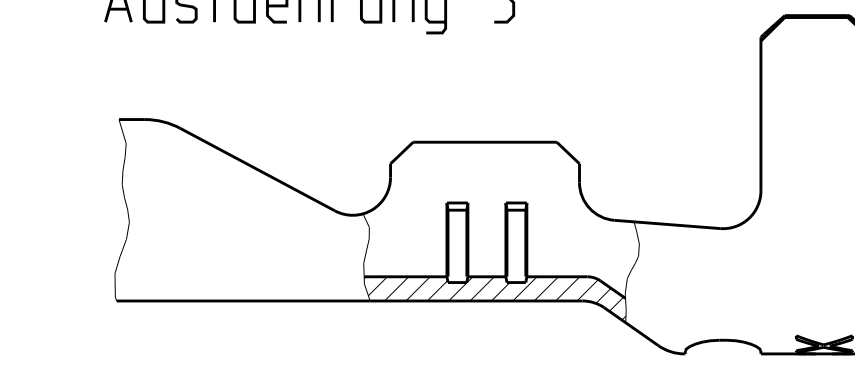

DESIGN 3 Ausfuehrung 3

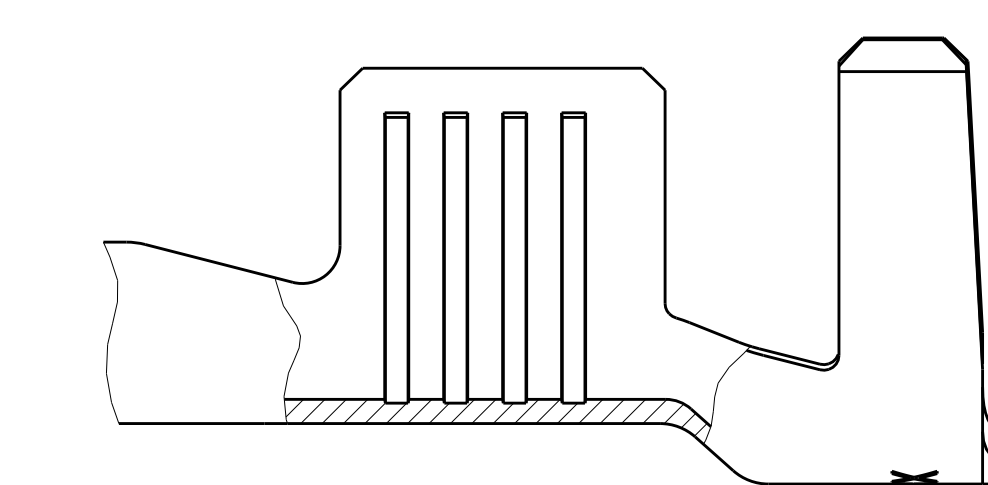

DESIGN 6 Ausfuehrung 6

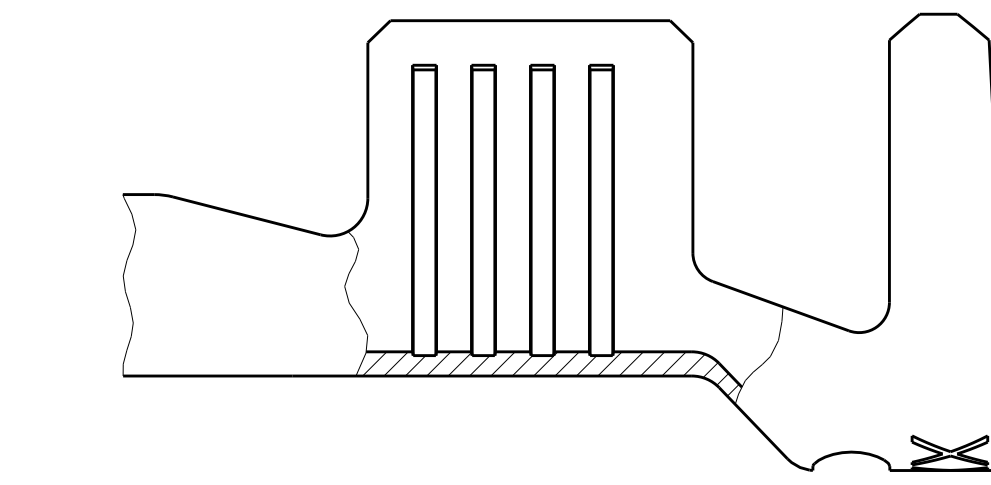

DESIGN 7 Ausfuehrung 7

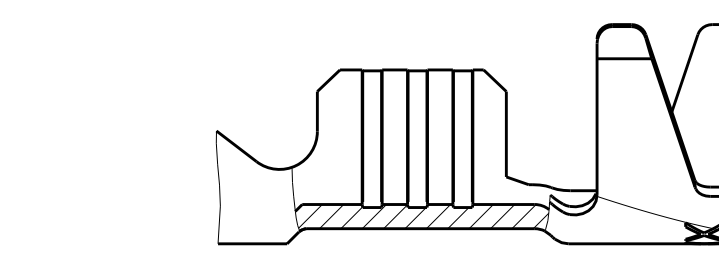

DESIGN 8 Ausfuehrung 8

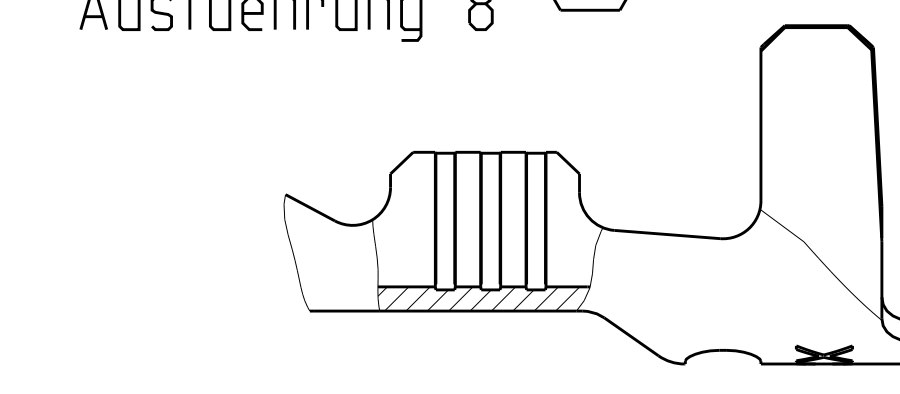

勝特力電材超市-龍山店 886-3-5773766
 勝特力電材超市-光復店 886-3-5729570
 勝特力電子(上海) 86-21-34970699
 勝特力電子(深圳) 86-755-83298787
<http://www.100y.com.tw>

TE ORDER-NO.	DESIGN REV	MATERIAL	SURFACE	DGB	INSULATION	WIRE CRIMP	INSUL. CRIMP	APPLICATION TOOL	HAND TOOL	TE ORDER-NO.	TE ORDER-NO.			
STRIPFORM	Ausfuehrung	Werkstoff	Oberflaeche	mm ²	Isolationsø	Drahtcrimp	Isolationscrimp	Anschlagwerkzeug	Handzange	SEALING PLUG	Blindstopfen			
Bandware					mm	mm	mm							
1-1719504-2	A	4	CuSn4	12 AWG	max. 3.0	E = 4.0 G = 4.2 D _{Dr} = 2.0	H = 5.3 K = 5.0 D = 3.6	1852291-3	-	3.5	6.0	7.6	26.8	828922-1
1-1719504-1	A	4	CuSn0.20	FLR	max. 3.7	E = 4.5 G = 4.7 D _{Dr} = 2.3	H = 6.2 K = 6.0 D = 4.3	MQC APPLICATOR 2-541537-2	539635-1 MATRIZE : 539727-2	4.3	6.9	8.5	28.5	828985 828986-1
2-968947-2	A	6	CuFe	FLR	max. 3.0	E = 3.6 G = 3.8 D _{Dr} = 1.7	H = 5.3 K = 5.0 D = 3.6	MQC APPLICATOR 2-878560-2	734440-1	3.5	6.0	7.6	26.8	828905 (Ø5.0)
1-968947-2	A	6	CuSn4	FLR	max. 2.1	E = 2.6 G = 2.9 D _{Dr} = 1.2	H = 5.0 K = 4.8 D = 3.3	MQC APPLICATOR 2-878559-2	734438-1	3.0	5.4	7.0	26.8	828904 (Ø5.0)
1-968947-1	A	6	CuSn4	FLR	max. 2.1	E = 2.1 G = 2.1 D _{Dr} = 0.8	H = 4.7 K = 4.5 D = 3.2	MQC APPLICATOR 2-878558-2	539635-1 MATRIZE : 539737-2	2.5	4.9	6.5	26.8	828904 (Ø5.0)
2-968946-2	A	3	CuFe	FLR	2.7 - 3.7	E = 4.5 G = 4.7 D _{Dr} = 2.3	H = 5.7 K = 5.9 D = 3.3	MQC APPLICATOR 2-541534-2	539635-1 MATRIZE : 539723-2	4.3	6.6	8.5	28.5	
2-962843-3	C	1	CuFe	FLK	2.4 - 3.7	E = 3.6 G = 3.8 D _{Dr} = 1.7	H = 5.5 K = 5.7 D = 3.2	MQC APPLICATOR 2-878552-2	734417-3	3.6	5.2	8.9	28.6	
2-962842-2	F	1	CuFe	FLR	2.1 - 2.9	E = 3.6 G = 3.8 D _{Dr} = 1.7	H = 4.3 K = 4.5 D = 2.6	MQC APPLICATOR 2-878551-2	734417-2	3.6	5.2	8.2	27.9	
2-962841-2	F	1	CuFe	FLR	1.4 - 2.1	E = 2.6 G = 2.8 D _{Dr} = 1.1	H = 3.2 K = 3.4 D = 1.8	MQC APPLICATOR 2-878550-2	734417-1	3.0	4.6	7.0	26.7	
2-963860-3	B	2	CuFe	FLR	1.3 - 1.6	E = 2.1 G = 2.1 D _{Dr} = 0.8	H = 2.9 K = 2.9 D = 1.4	MQC APPLICATOR 2-878549-2	734538-1	2.5	3.7	5.8	25.5	

THIS DRAWING IS A CONTROLLED DOCUMENT.		REV: 14 JUN 1999	DATE: 14 JUN 1999	BY: K. Gerlach	CHK: M. Bleicher
DIMENSIONS:	UNIT: mm	TOLERANCES UNLESS OTHERWISE SPECIFIED:	±0.2	APPROXIMATE WEIGHT:	114-18051
MATERIAL:	0 P/PC	1 P/PC	2 P/PC	3 P/PC	4 P/PC
FINISH:	114-18051	114-18051	114-18051	114-18051	114-18051
Customer Drawing	Customer Drawing	Customer Drawing	Customer Drawing	Customer Drawing	Customer Drawing

2:1

2,8x0,8mm Flat Contact

CONTENT

1.	INTRODUCTION	2
2.	REFERENCED DOCUMENTS	
2.1	Customer Drawings	2
2.2	Product Specifications	2
2.3	Application Specification	2
2.4	Instruction Material	2
2.5	National / International Standards	2
3.	DESCRIPTION	
3.1	Contacts for Wires	3
3.2	Contacts for Single-Wire Sealing	4
4.	REQUIREMENTS	5
4.1	Wires	5
4.2	Cut-Off and Burr	5
4.3	Wire Crimp	5
4.4	Insulation Crimp or Single-Wire Seal Crimp	6
4.5	Contact Area	6
4.6	Shape and Position Tolerances	7

FIGURES / TABLES

Fig. 1	Flat Contacts with Wires	3
Fig. 2	Flat Contacts with Single Wire Seals	4
Fig. 3	Shape and Position Tolerances	7
Fig. 4	Shape and Position Tolerances	8
Table 1	Crimping Data for Flat Contacts with Wires	9
Table 2	Crimping Data for Flat Contacts with Single Wire Seals	10
Table 3	Crimping Data for Flat Contacts "Typ A" with Wires	10
Table 4	Crimping Data for Flat Contacts "Typ A" with Single Wire Seals	11
Table 5	Comparison AWG / ISO Wires	12

1. INTRODUCTION

This specification covers the special guidelines for the application of the Flat Contact System 2,8mm and the Flat Contact System 2,8mm “ Type A “.

The instructions are intended primarily for automatic or semi-automatic application of all versions (for both wires and single-wire sealing), but may also be applied, if agreed, to hand tools.

The various contact types are listed in Tables 1 and 2, sorted by their wire ranges and crimping data.

The various Flat Contact System 2,8mm “ Type A “ are listed in Tables 3 and 4, sorted by their wire ranges and crimping data.

2. REFERENCED DOCUMENTS

2.1 Customer Drawings

There is a customer drawing showing the dimensions and materials for each part number.

In the case of a conflict between this document and a customer drawing, the customer drawing takes precedence.

2.2 Product Specification

The Product Specification 108-18063 describes the characteristics of these contacts, together with the electrical and mechanical requirements.

2.3 Application Specifications

The general guidelines laid down in Application Specifications 114-18022 and 114-18018 also apply to the crimp quality.

2.4 Instructional Material

CM 5128	Contains information about crimping machines for MQC crimping tools.
AI 8025	Describes the MQC crimping tool.
IS 6764	Instruction sheet for AMP CERTI-LOK* hand tool.
IS 7424	Explains how to measure the crimp height.

2.5 National / International Standards

DIN 72 551 T5/05.92	Unscreened low tension cables (FLR)
DIN 72 551 T6/01.92	Unscreened low tension cables (FLR)
DIN ISO 6722 T1/04.85	Unscreened low tension cables (FLK)
DIN ISO 6722 T2/04.84	Unscreened low tension cables (FLK)
DIN ISO 6722 T3/08.87	Unscreened low tension cables (FLK)
DIN IEC 352 T2/04.92	Solderless electrical connections, crimped connections

3. DESCRIPTION

The terms shown below are used in the specification.

3.1 Contacts for Wires

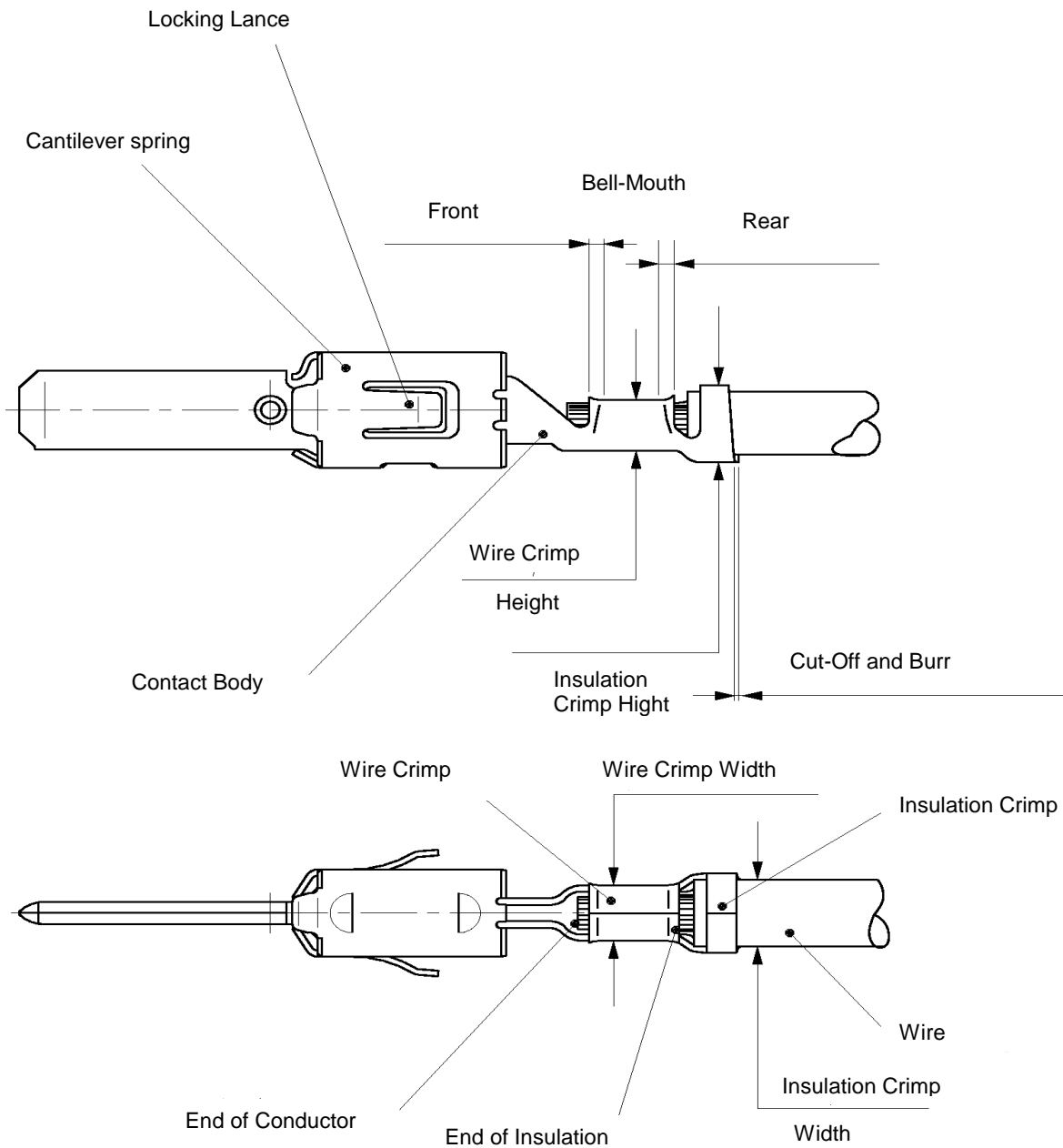

Fig. 1

3.2 Contacts for Single-Wire Sealing

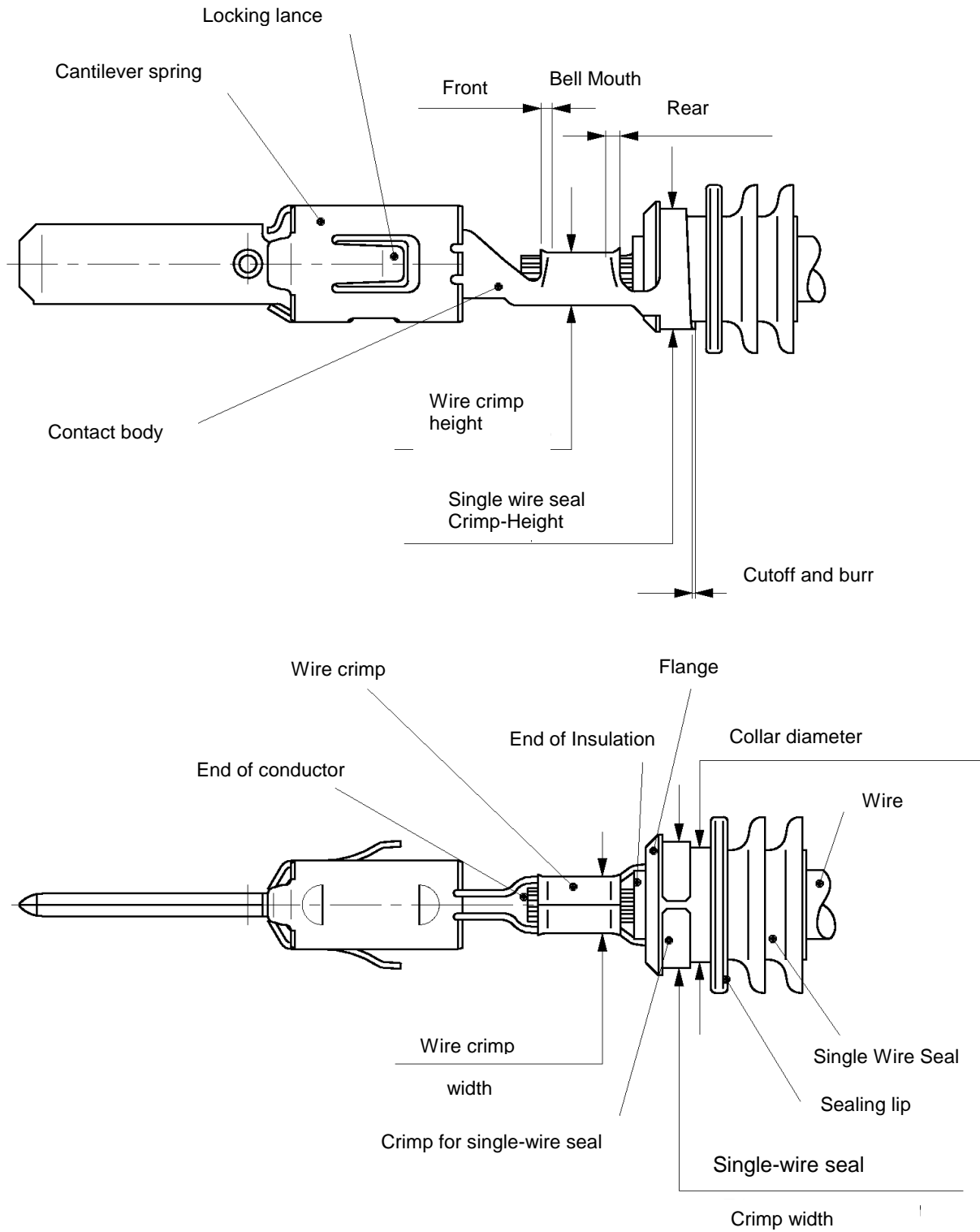

Fig. 2

4. REQUIREMENTS

4.1 Wires

A Selection

The contacts and single-wire seals are designed for FLR conductors to DIN 72 551 Part 5 and Part 6 or FLK conductors to DIN ISO 6722 Parts 1-3 (formerly DIN 72551 Part 2), as well as FLR and FLU wires in accordance with LV112-1.

Other wires require the approval of the Engineering Department. Single termination is preferred. Double termination is possible within the wire range with FLR conductors; with FLK conductors, this is possible only with restrictions.

B Preparation

The wire must be stripped to the lengths shown in Tables 1 till 4.

Take care that the individual strands of the wire are not bent or cut off.

For single wire sealing, care must be taken that the insulation of the wire in the sealing area is not damaged, compressed or deformed.

The insulation must be clean and free of contamination.

4.2 Cut-Off and Burr

The cutoff must be visible after crimping.

The maximum length of the cutoff is 0.5 mm.

Any burrs at the shearing point may not exceed 0.08 mm.

4.3 Wire Crimp

A Wire position

After crimping, the end of the wire must extend 0.1 ... 1.0 mm beyond the front end of the wire crimp.

B Crimping data

The shape, height and width of the crimp, and the wire range, are shown in Tables 1 till 4.

C Extraction forces

The crimp extraction forces must fulfill the requirements of DIN IEC 352 Part 2.

D Crimp bell-mouth

The size of the rear bell-mouth depends on the wire range:

0.2 - 0.5 mm² : 0.25 ± 0.15 mm

0.5 - 2.5 mm² : 0.40 ± 0.20 mm

A front bell-mouth is permissible.

4.4 Insulation crimp or Crimp for Single-Wire Seal

A Position of the end of the insulation

In the case of contacts for crimping on wire, the end of the insulation must be visible in the transition between the wire crimp and the insulation crimp.

In no case may the insulation be crimped in the wire crimp; conversely, the insulation must extend at least to the front edge of the insulation crimp.

In the case of contacts for single-wire sealing, the end of the insulation must be flush with the front edge of the single-wire seal or may project by up to 1.0 mm from this seal.

B Crimping data for wires

The shape and width of the crimp, and the insulation diameter, are shown in Table 1 and 3.

The crimp height is adjusted either after the bending test to DIN 41611 Part 1 or after the wrapping test to DIN 41640 Part 66.

C Crimping data for single-wire seals

The shape and width of the crimp, and the part number of the single-wire seal, are shown in Table 2 and 4. The crimp height is correctly adjusted if the crimp encloses the seal in the shape of a circle.

Oval enclosure as the result of differing insulation diameters is permissible.

D Position of the single-wire seal

Single-wire seals without a collar on the sleeve must be flush with the front edge of the crimp or may project up to 1 mm from the crimp.

In the case of single-wire seals with a collar on the sleeve, this collar is positioned in front of the front edge of the crimp.

The collar must be centered within the window on the bottom of the crimp.

4.5 Contact Area

After crimping, neither the cantilever spring, the locking lances nor the contact body may be bent or deformed.

4.6 Shape and Position Tolerances

A Contacts for crimping on wire (see Fig. 3)

Parallelism

The bottom of the wire crimp or of the insulation crimp must be parallel with the contact body, with a tolerance of 0,3 mm.

Symmetry

The width of the insulation crimp must be symmetrical with the contact body, with a tolerance of 0,3 mm.



Bild 3

B Contacts for single-wire seals (Fig. 4)

Parallelism

The bottom of the wire crimp or of the insulation crimp must be parallel with the contact body, with a tolerance of 0.3 mm.

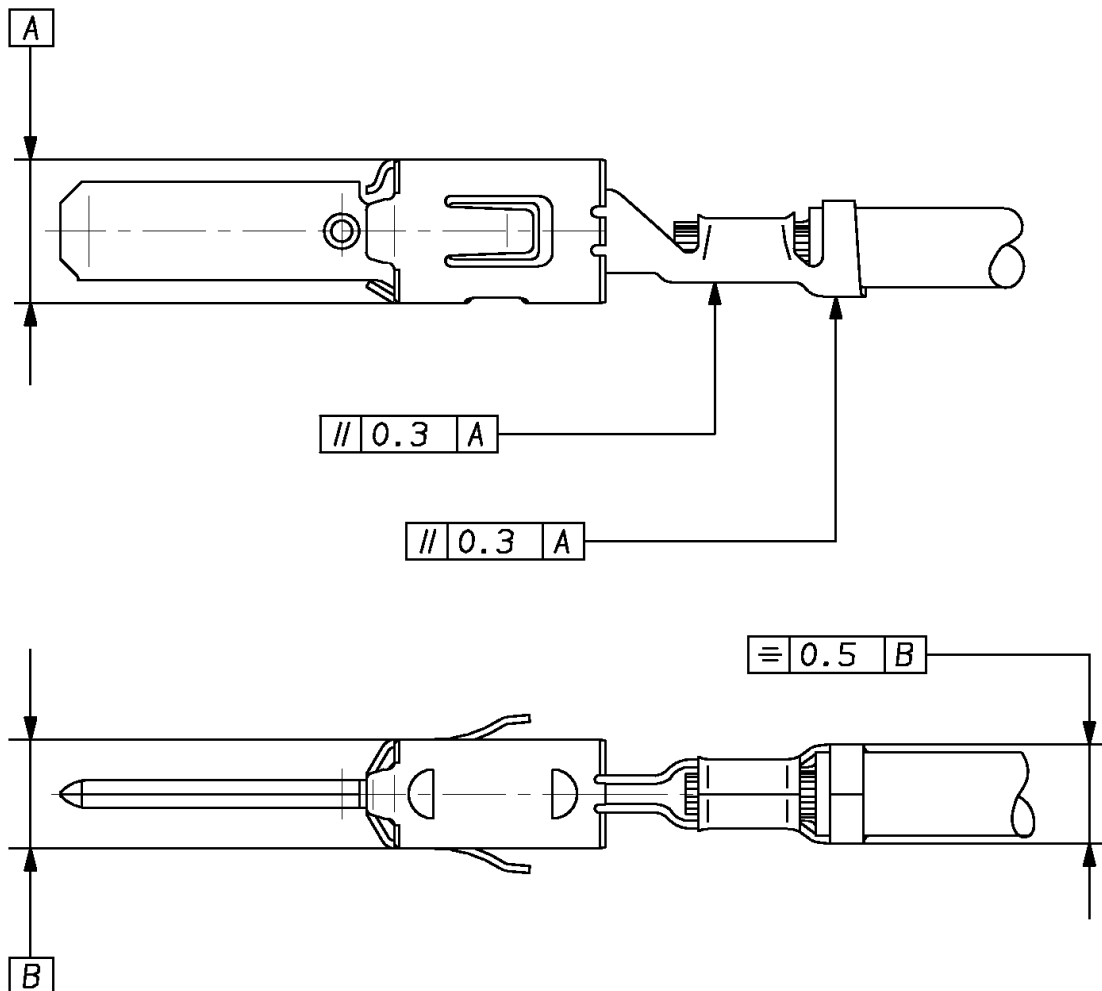
Symmetry

The crimp for the single-wire seal must lie within a symmetrical tolerance of 0,5 mm relative to the longitudinal axis of the contact.

The single-wire seal must be symmetrical in both directions with the longitudinal axis of the contact, with a tolerance of 0,8 mm.

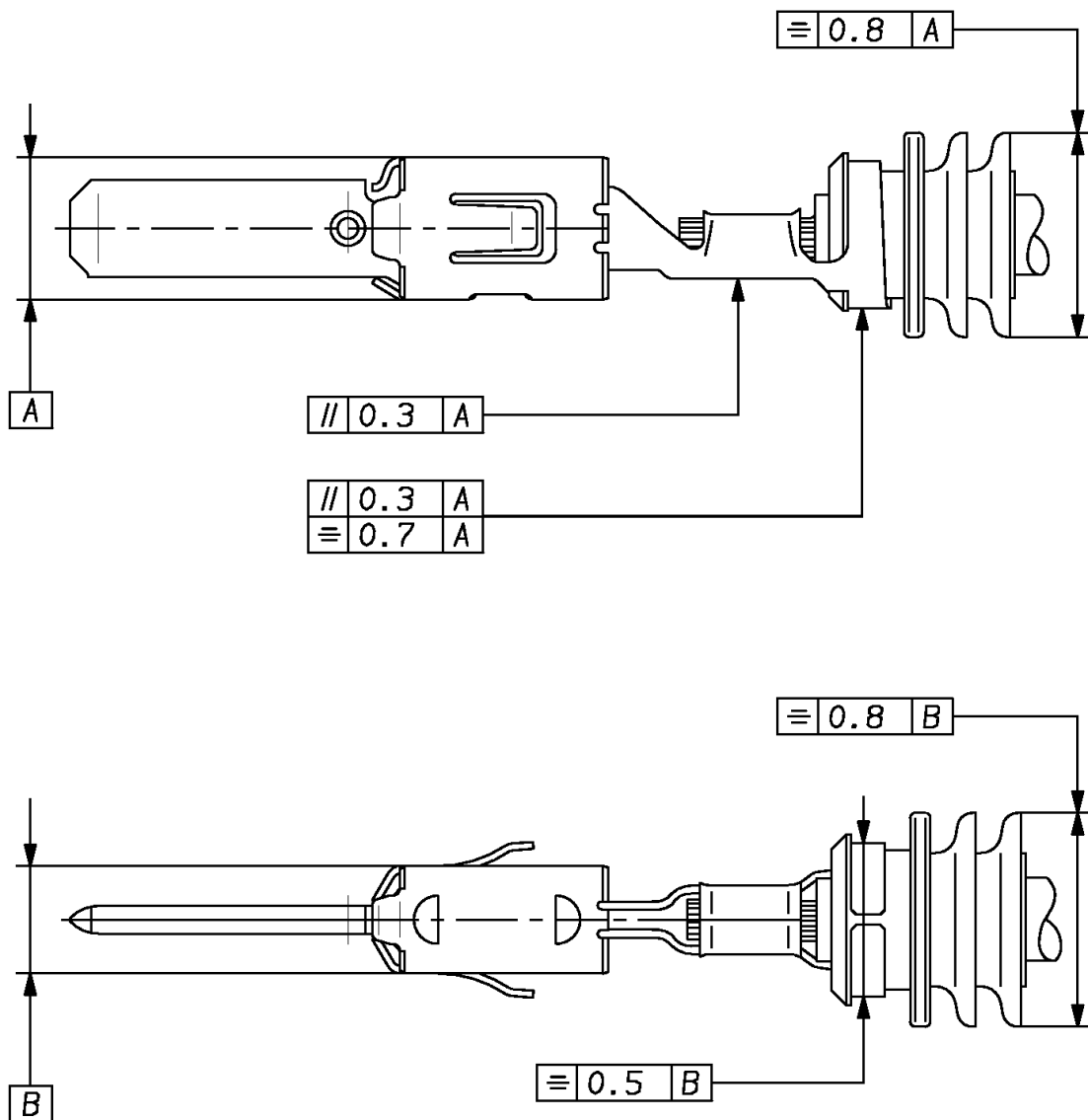

Fig. 4

Table 1

Crimping Data for TAB 2,8mm with wires														
Part-No.		Wire Size (mm ²)	Insulation Diameter (mm)			Stripped length (mm) ±0,3	Wire Crimp				Insulation- crimp		Crimping Tool	Die for hand- crimping tool
Strip	Loose Piece		FLU	FLR	FLK		Width (mm)	Height (mm) ±0,05		Shape	Width (mm) ±0,2	Shape		
							1)	2)						
963860	963861	0,20 0,25 0,35 0,50	3)	1,15-1,6		3,5	1,60	0,98±0,03 1,00±0,03 1,05±0,03 1,12±0,03	- - - -	F	2,30	○	x-878549-x	734538-1
962841	963745	0,50 0,75 1,00	3)	1,4-2,0		4,2	2,05	1,18 1,27 1,36	1,15 1,18 1,20	F	2,55	○	x-878550-x	734417-1
962842	963746	1,50 2,00 2,50	3)	2,1-2,9		5,0	2,55	1,58 1,73 1,88	- - -	F	3,30	○	x-878551-x	734417-2
962843	963747	1,50 2,00 2,50	3)	-	2,4-3,7	5,0	2,55	1,58 1,73 1,88	- -	F	3,95	○	x-878552-x	734417-3
2141598	-	1,50 2,50	3)	-	2,4-3,7	5,0	2,55	1,58 1,88	- -	F	3,95	○	x-2151620-x	734417-3
968946	968965	4,00	3)	3,4-3,7		-	3,05	2,15	-	F	4,1	○	x-541534-x	-
2141600	-	4,00	3)	3,4-3,7		-	3,05	2,15	-	F	4,1	○	x-2151634-x	-

1) current standard

2) preferred standard to meet new requirement @ LV214-2 slow motion bending test

3) Contact-, wire combination has not yet been considered

Table 2

Crimping Data for TAB 2.8mm with single wire seals														
Part-No.		Wire Size (mm ²)	Insulation Diameter (mm)		Stripped length (mm) ±0,3	Wire Crimp			Insulation-crimp		Crimping Tool	Die for handcrimping tool	Single wire seal	
Strip	Loose Piece		FLU	FLR		Width (mm)	Height (mm) ±0,05		Shape	Width (mm) ±0,2			Shape	FLU
							1) 2)							
965982	965983	0,20 0,25 0,35 0,50	3)	Max.2,1	4,0	1,60	0,98±0,03 1,00±0,03 1,05±0,03 1,12±0,03	- - - -	└	3,95	○	x-878558-x	-	828904
962915	963748	0,50 0,75 1,00	3)	Max.2,1	4,5	2,05	1,18 1,27 1,36	1,15 1,18 1,20	└	4,05	○	x-878559-x	734438-1	828904
962916	963749	1,50 2,00 2,50	1.9-2.7	Max.3,0	5,0	2,55	1,58 1,73 1,88	- - -	└	4,30	○	x-878560-x	734440-1	828904 - 828905
968947*	968966	4,00	3)	Max.3,7	-	3,05	2,15	-	└	5,10	○	x-541537-x	-	828985

1) current standard

2) preferred standard to meet new requirement @ LV214-2 slow motion bending test

3) Contact-, wire combination has not yet been considered

*Attention: Construction of the Contact Cavity in the area of the single wire seal is 6,4 mm +0,1/-0,05.

Table 3

Crimping Data for TAB 2,8mm "Type A" with wire													
Part-No.		Wire Size (mm ²)	Insulation Diameter (mm)		Stripped length (mm) ±0,3	Wire Crimp			Insulation-crimp		Crimping Tool	Die for hand-crimping tool	
Strip	Loose Piece		FLU	FLU		Width (mm)	Height (mm) ±0,05		Shape	Width (mm) ±0,2			Shape
							1) 2)						
964292	964291	0,20 0,25 0,35 0,50	3)	1,15-1,6	3,5	1,60	0,98±0,03 1,00±0,03 1,05±0,03 1,12±0,03	- - - -	└	2,30	○	x-878950-x	539664-2
2141874	-	0,35	3)	1,15-1,6	3,5	1,6	-	1,08±0,03	└	2,30	○	x-878950-x	539664-2
964294	964293	0,50 0,75 1,00	3)	1,4-2,1	4,0	2,05	1,18 1,27 1,36	1,15 1,18 1,20	└	2,55	○	x-878937-x	539664-2
964296	964295	1,25 1,50 2,00 2,50	3)	2,2-3,0	4,3	2,55	1,48 1,55 1,70 1,86	- 1,47 - 1,76	└	3,60	○	x-878704-x	539664-2

1) current standard

2) preferred standard to meet new requirement @ LV214-2 slow motion bending test

3) Contact-, wire combination has not yet been considered

Table 4

Crimping Data for TAB 2.8mm "Type A" with single wire seals															
Part-No.		Wire Size (mm ²)	Insulation Diameter (mm)			Stripped length (mm) ±0,3	Width (mm)	Wire Crimp			Insulation -crimp		Crimping Tool	Die for hand-crimping tool	Single wire seal
Strip	Loose Piece		FLU	FLR	AWG			Height (mm) ±0,05	Shape	Width (mm) ±0,2	Shape				
							1)	2)							
964298	964297	0,20 0,25 0,35 0,50	3)	1,15-1,6	-	3,5	1,60	0,98 ^{±0,03} 1,00 ^{±0,03} 1,05 ^{±0,03} 1,12 ^{±0,03}	- - - -	F	3,95	O	x-878952-x	539650-2	963294-1
2141876	-	0,35	3)	1,15-1,6	-	3,5	1,60	-	1,08 ^{±0,03}	F	3,95	O	x-878952-x	539650-2	963294-1
964300	964299	0,50 0,75 1,00	3)	1,4-2,1	-	4,5	2,05	1,18 1,27 1,36	1,15 1,18 1,20	F	4,10	O	x-878953-x	539650-2	963294-1
964302	964301	1,50 2,00 2,50	3)	2,2-3,0	-	4,9	2,55	1,55 1,70 1,86	1,47 - 1,76	F	4,20	O	x-878954-x	539650-2	963292-1
1719504	1719503		-	-	3,3 (TXL) 3,8 (GXL)	5,6	CB1 3.05 CB2 3.3	2	-	F	5,08	O	1852291-x	-	828905-x 184141-x

1) current standard

2) preferred standard to meet new requirement @ LV214-2 slow motion bending test

3) Contact-, wire combination has not yet been considered

Table 5

AWG / ISO Comparison in addition to Appl. Spec. 114-18051

2.8mm tab Basic part number	Wire size ISO 6722		USA		Outer diameter (Insulation)	Single Wire Seal
	Cross section	Type	SAE J1128	AWG Cable type		
965982 Applicator 2-878558-2	0,35mm ²	FLR			1,30-1,40mm	828904-1
			22	TXL	1,50-1,75mm	828904-1
962915 Applicator 2-878559-2	0,5mm ²	FLR			1,58-1,70mm	828904-1
			20	TXL	1,68-1,93mm	828904-1
	0,75mm ²	FLR			1,78-1,90mm	828904-1
			18	TXL	1,88-2,13mm	828904-1
	1,0mm ²	FLR			1,98-2,10mm	828904-1
	0,5mm ²	FLK			2,06-2,30mm	828905-1
			20	GXL	2,06-2,41mm	828905-1
	0,75mm ²	FLK			2,26-2,50mm	828905-1
1,0mm ²	FLK			2,18-2,54mm	828905-1	
962916 Applicator 2-878560-2			16	TXL	2,16-2,41mm	828905-1
	1,5mm ²	FLR			2,28-2,40mm	828905-1
	2,0mm ²	FLR			2,66-2,80mm	828905-1
			14	TXL	2,51-2,77mm	828905-1
	2,5mm ²	FLR			2,86-3,00mm	828905-1
			16	GXL	2,57-2,92mm	828905-1
	1,5mm ²	FLK			2,86-3,00mm	828905-1
			14	GXL	2,82-3,18mm	828905-1
	2,5mm ²	FLK			3,32-3,60mm	---

G	FLU wires added	M. Merz	S. Raab	05.02.2015
LTR	REVISION RECORD	DWN	APP	DATE