

THIS INFORMATION IS CONFIDENTIAL AND IS DISCLOSED TO YOU ON CONDITION THAT NO FURTHER DISCLOSURE IS MADE BY YOU TO OTHER THAN AMP PERSONNEL WITHOUT WRITTEN AUTHORIZATION FROM AMP (TAIWAN) LTD. DIMENSIONS IN MILLIMETERS. DO NOT SCALE PRINT.

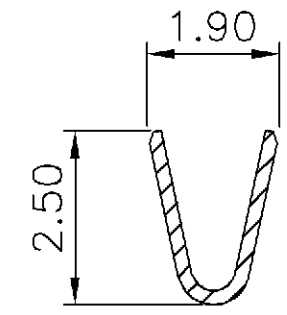

SEC: A-A

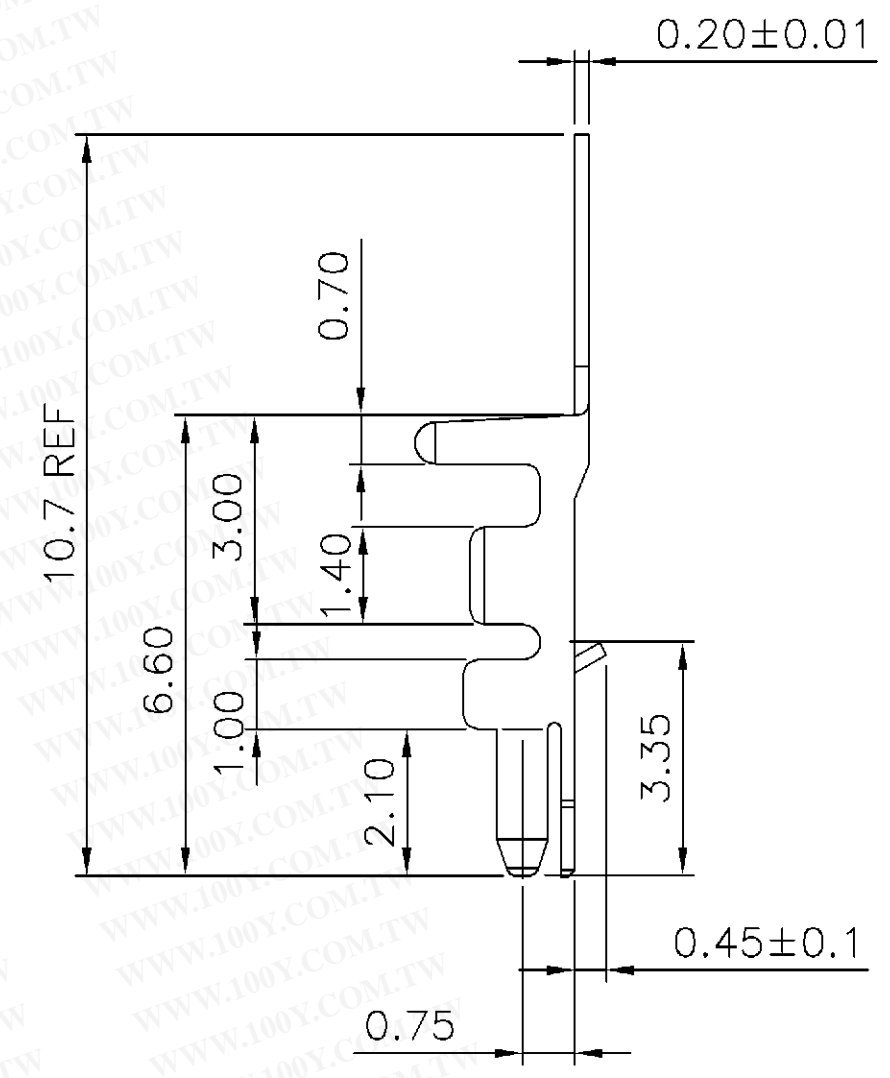
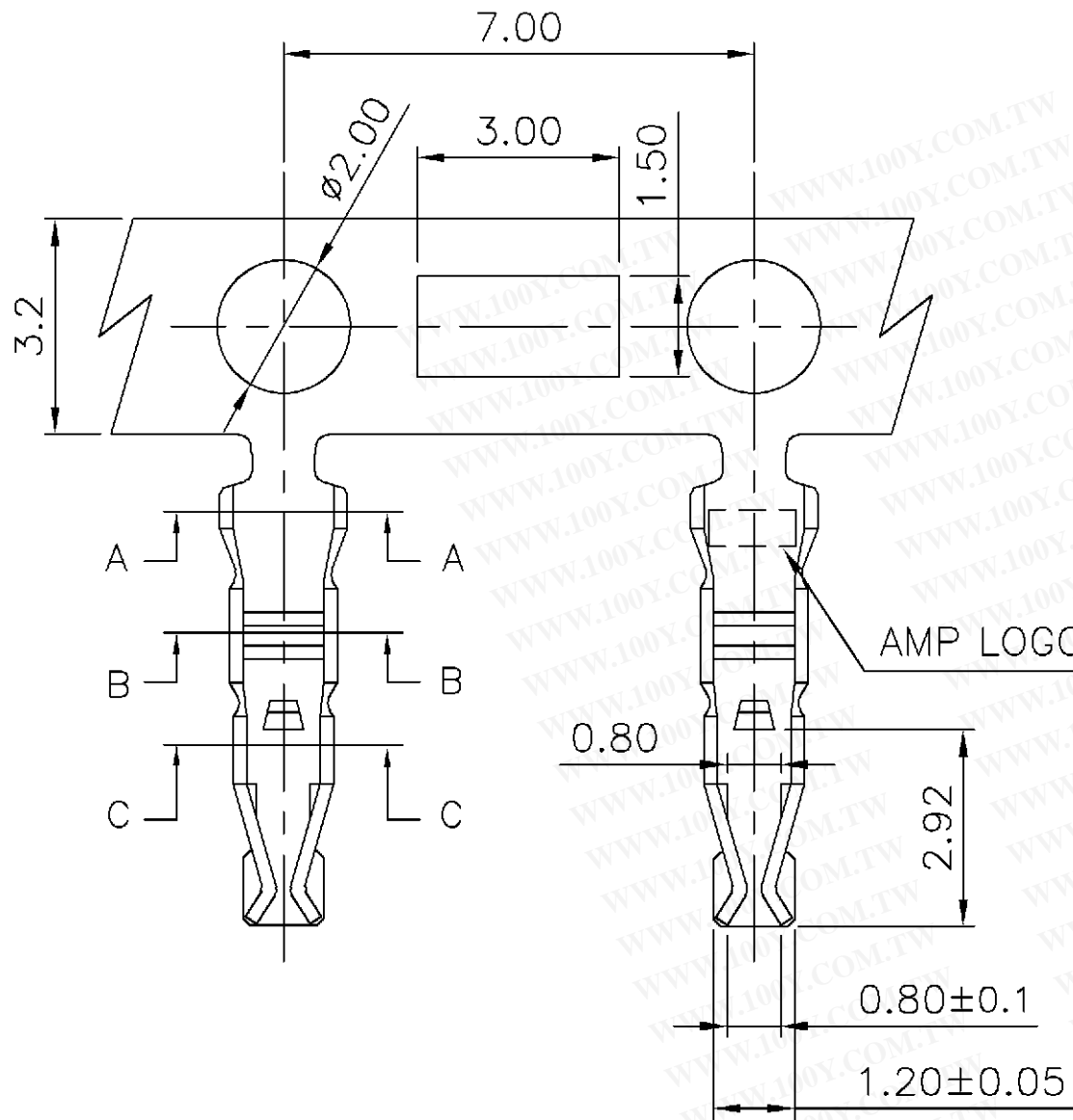
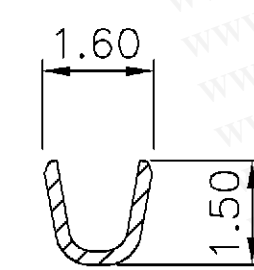

SEC: B-B

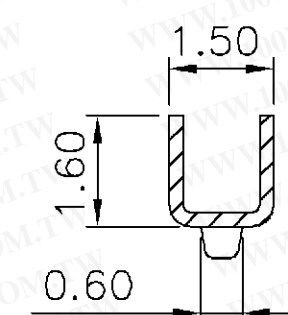

SEC: C-C

- NOTE:
- MATERIAL :  
TERMINAL : PHOSPHOR BRONZE, T=0.20mm.
  - FINISH:  
TERMINAL : 60u" MIN TIN PLATED ON CONTACT AREA.  
20u" MIN. NICKEL UNDERPLATED OVER ALL.
  - QUALIFICATION TEST REPORT: 501-57218.

1470106-1  
PART NUMBER

DIMENSION : 0 PLC ± 1 PLC ±0.30 2 PLC ±0.20 3 PLC ±0.10 ANGLES ±'	DWN O. HU 12-AUG-2003	 TYCO HOLDINGS (BERMUDA) VII LTD. TAIWAN BRANCH
MATERIAL SEE NOTE	CHK A. WU 12-AUG-2003	
FINISH SEE NOTE	APVD J. CHENG 12-AUG-2003	NAME 2.0 MM PITCH CRIMP CONTACT
	PRODUCT SPEC 108-57217	LOC DW A <sub>3</sub>
	APPLICATION SPEC 114-57D13	SIZE C-1470106
	WEIGHT	SCALE --
		DRAWING NO C-1470106
		REV A
		SHEET 1 OF 2

REV	DESCRIPTION	ECN	BY	DATE
A	REVISED	FZ00-0183-03	OH/AW	18AUG 2003
O	FIRST RELEASED	FZ00-0049-02	OH/JC	06MAR 2002
LTR	REVISION RECORD	ECN	DWN/CHK	DATE

勝特力材料 886-3-5753170  
勝特力电子(上海) 86-21-34970699  
勝特力电子(深圳) 86-755-83298787  
[Http://www.100y.com.tw](http://www.100y.com.tw)

THIS INFORMATION IS CONFIDENTIAL AND IS DISCLOSED TO YOU ON CONDITION THAT NO FURTHER DISCLOSURE IS MADE BY YOU TO OTHER THAN AMP PERSONNEL WITHOUT WRITTEN AUTHORIZATION FROM AMP (TAIWAN) LTD.  
 DIMENSIONS IN MILLIMETERS. DO NOT SCALE PRINT.

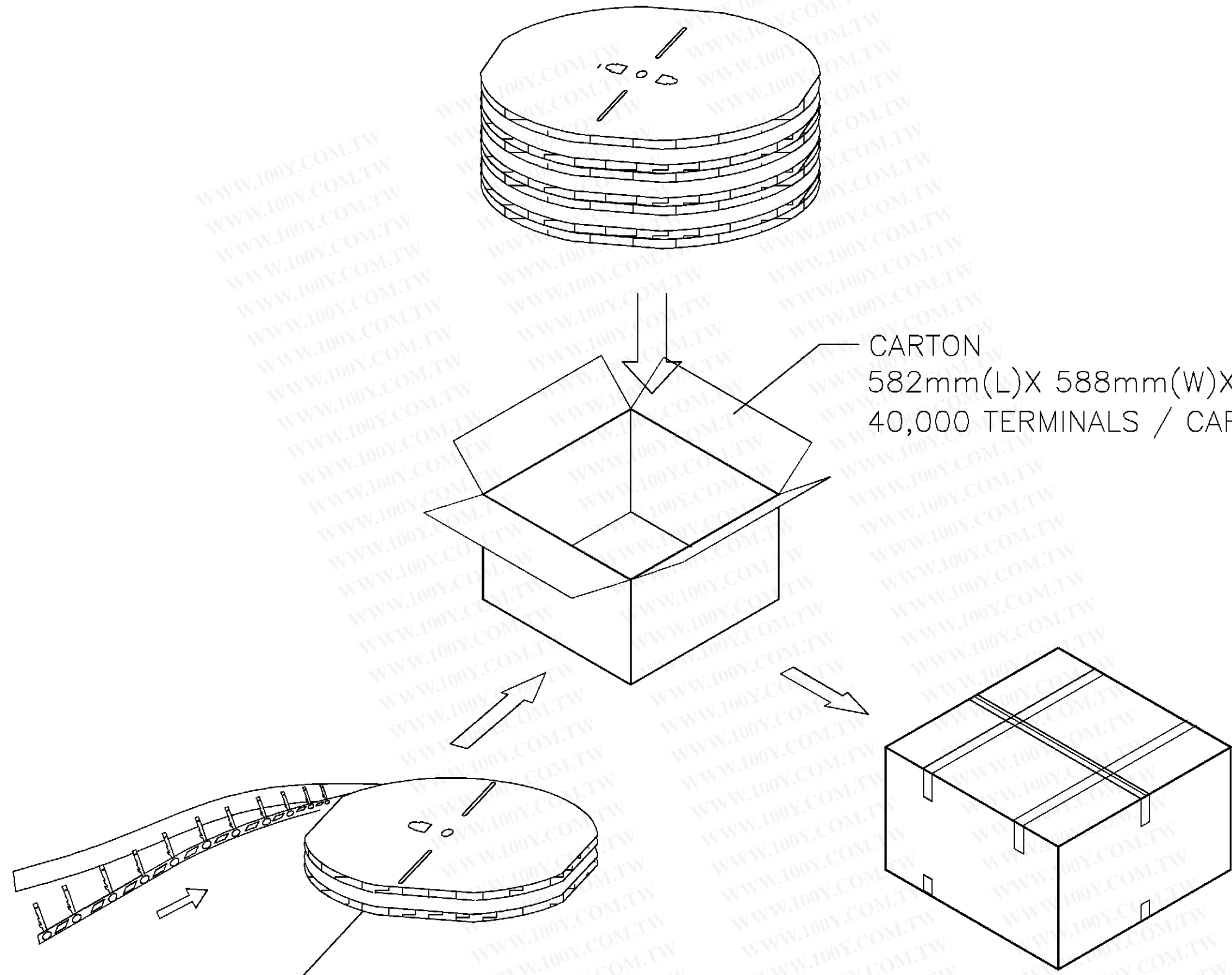

勝特力材料 886-3-5753170  
 勝特力电子(上海) 86-21-34970699  
 勝特力电子(深圳) 86-755-83298787  
[Http://www.100y.com.tw](http://www.100y.com.tw)

REEL  
 DIAMETER: ø580mm.  
 10,000 TERMINALS / REEL

CARTON  
 582mm(L)X 588mm(W)X 112mm(H)  
 40,000 TERMINALS / CARTON

DIMENSION :		DWN	O. HU	TYCO		TYCO HOLDINGS (BERMUDA)		
0 PLC ±			12-AUG-2003	Electronics		VII LTD. TAIWAN BRANCH		
1 PLC ±		CHK	A. WU	NAME				
2 PLC ±			12-AUG-2003	2.0 MM PITCH CRIMP CONTACT				
3 PLC ±		MATERIAL	APVD	J. CHENG	PRODUCT SPEC			
ANGLES ±		SEE NOTE		12-AUG-2003	APPLICATION SPEC			
		FINISH	WEIGHT		LOC	SIZE	DRAWING NO	REV
		SEE NOTE			DW	A <sub>3</sub>	C-1470106	A
					SCALE	SHEET		
					---		2 OF 2	

SEE SHEET 1.	ECN	DWN	CHK	DATE
LTR	REVISION RECORD			