

LOC	DIST	REVISIONS					
		P	LTN	DESCRIPTION	DATE	OWN	APVD
GP	00						
		C1		REVISED PER ECO-11-004835	11MAR2011	RK	HMR
		D		REVISED PER ECO-11-019224	05JAN2012	TX	AC
		D2		REVISED PER ECR-18-001078	23JAN2018	IT	SH

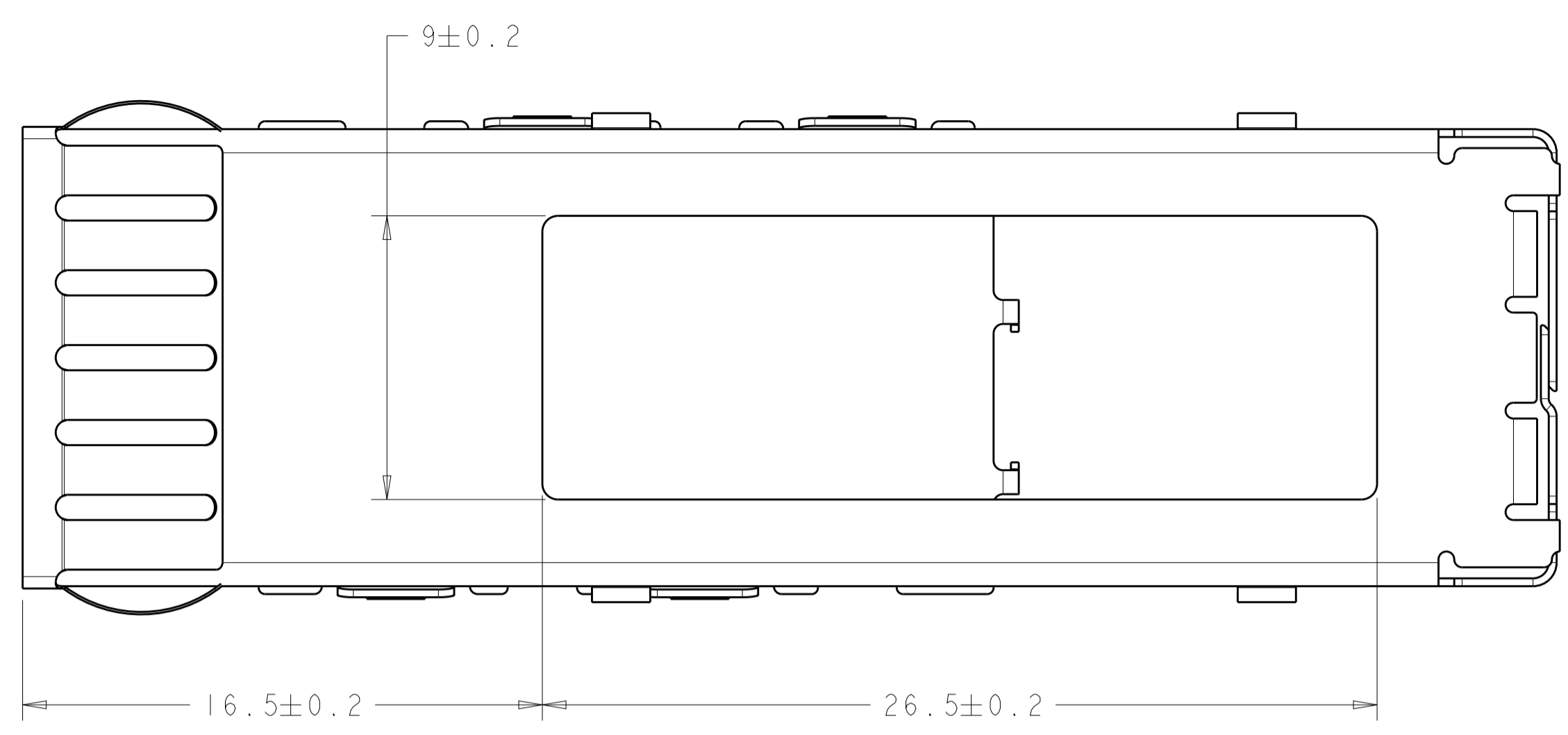

- 1 MATERIAL:
CAGE ASSEMBLY - 0.25mm THICK NICKEL-SILVER ALLOY.
EMI SPRINGS - COPPER ALLOY.
- 2 FINISH:
EMI SPRINGS - 0.8um MIN MATTE TIN OVER 0.8um MIN NICKEL
NON PLATED EDGES PERMISSIBLE.
- 3. MATES WITH SFP MSA COMPLIANT TRANSCEIVERS.
- 4 PADS AND VIAS CHASSIS GROUND.
- 5 DATUMS AND BASIC DIMENSIONS ESTABLISHED BY CUSTOMER.
- 6. MINIMUM PC BOARD THICKNESS:
SINGLE SIDED = 1.50mm.
- 7. NOTE DELETED

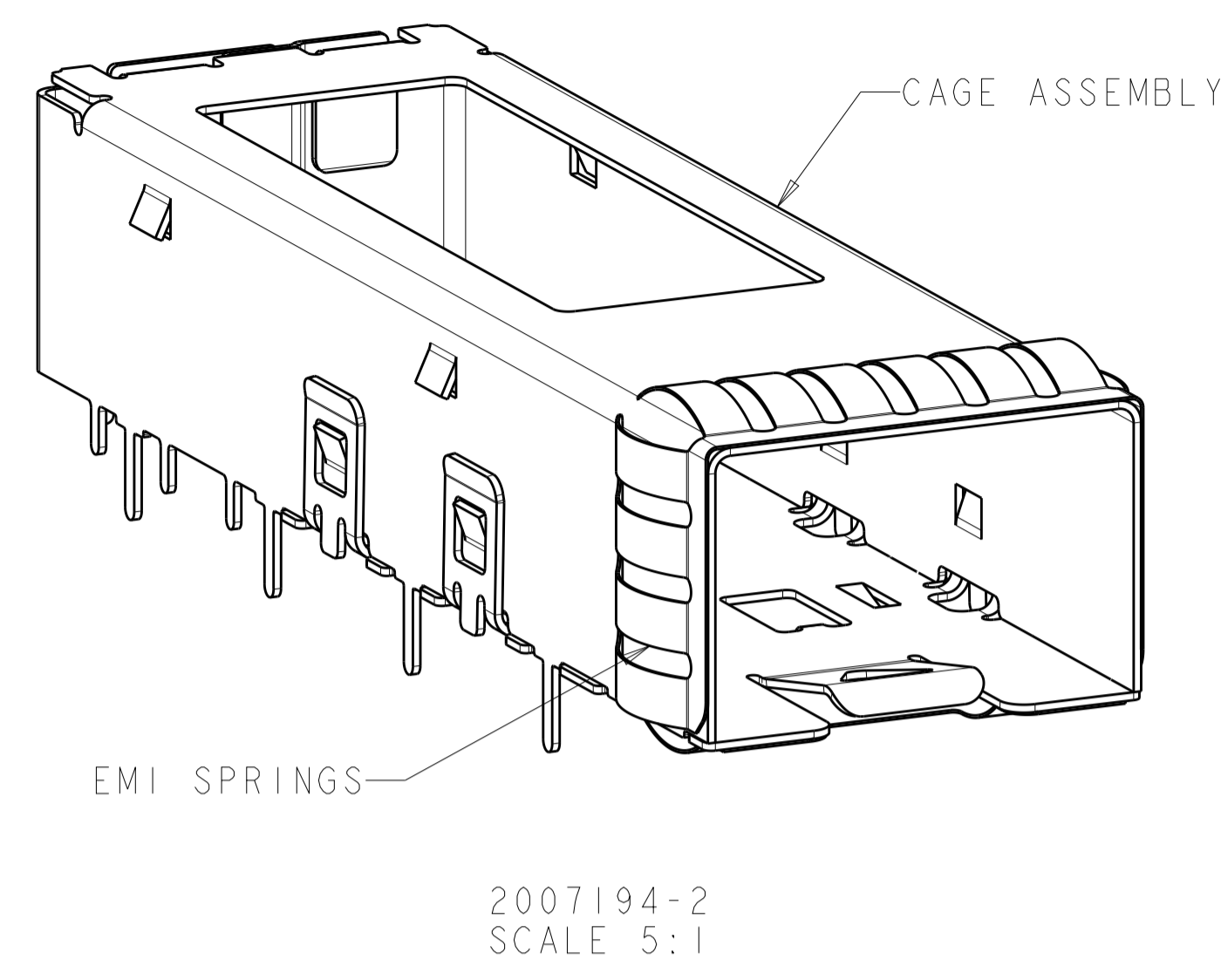
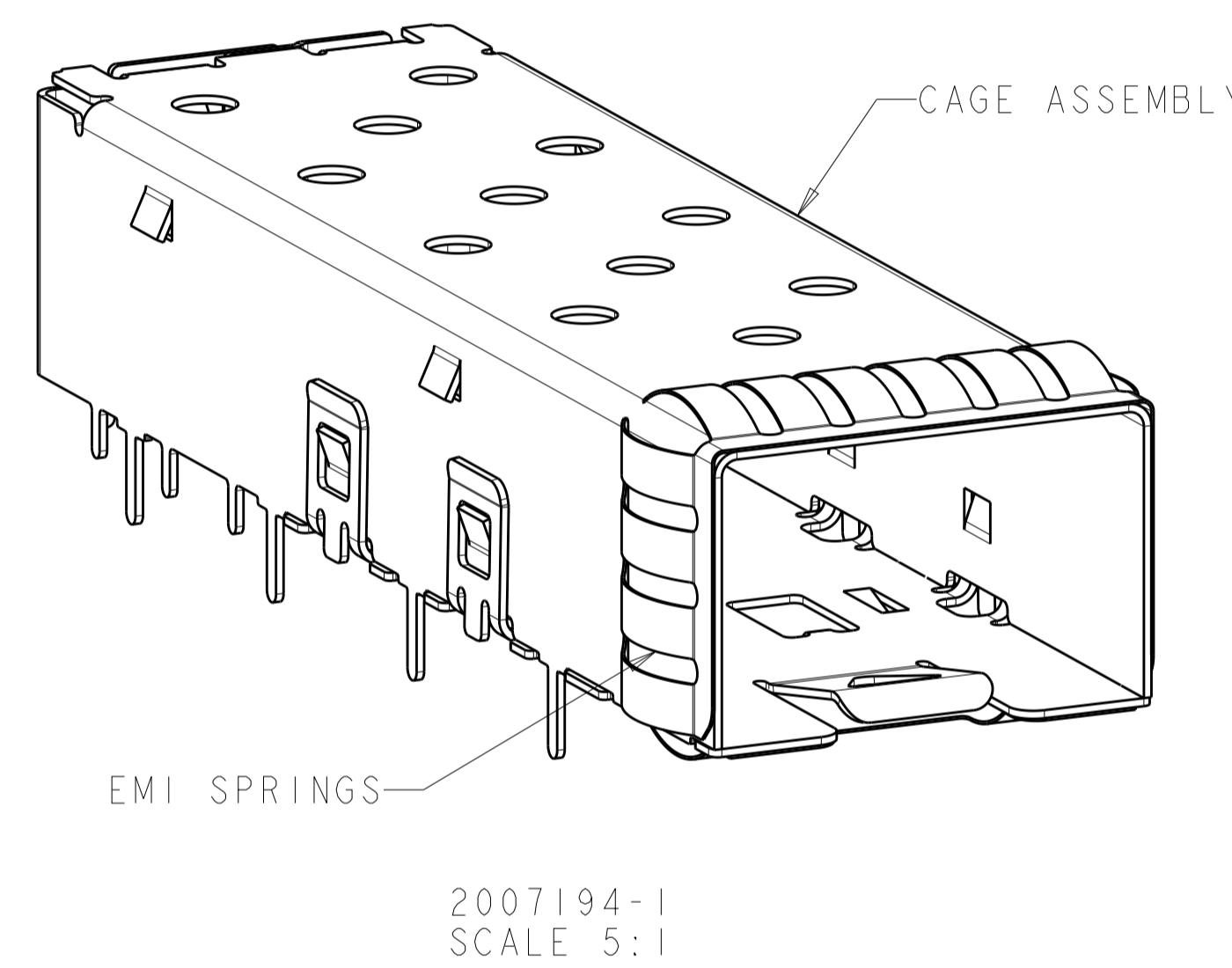

2007194-2
SAME AS 2007194-1 EXCEPT AS SHOWN
TOP VIEW

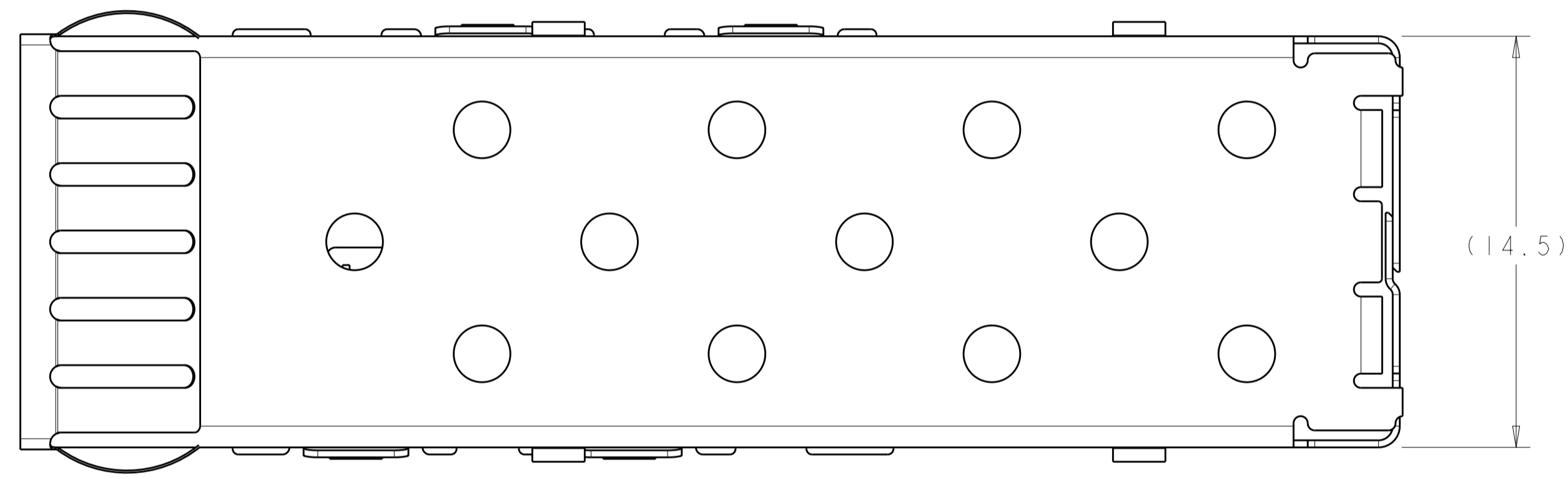

2007194-1
TOP VIEW

勝特力電材超市-龍山店 886-3-5773766
 勝特力電材超市-光復店 886-3-5729570
 勝特力电子(上海) 86-21-34970699
 勝特力电子(深圳) 86-755-83298787
<http://www.100y.com.tw>

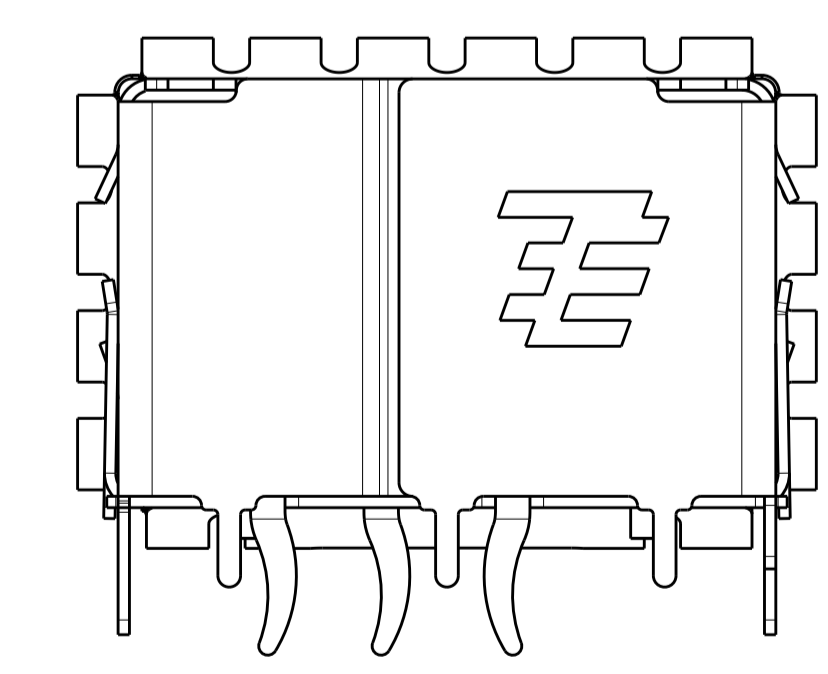
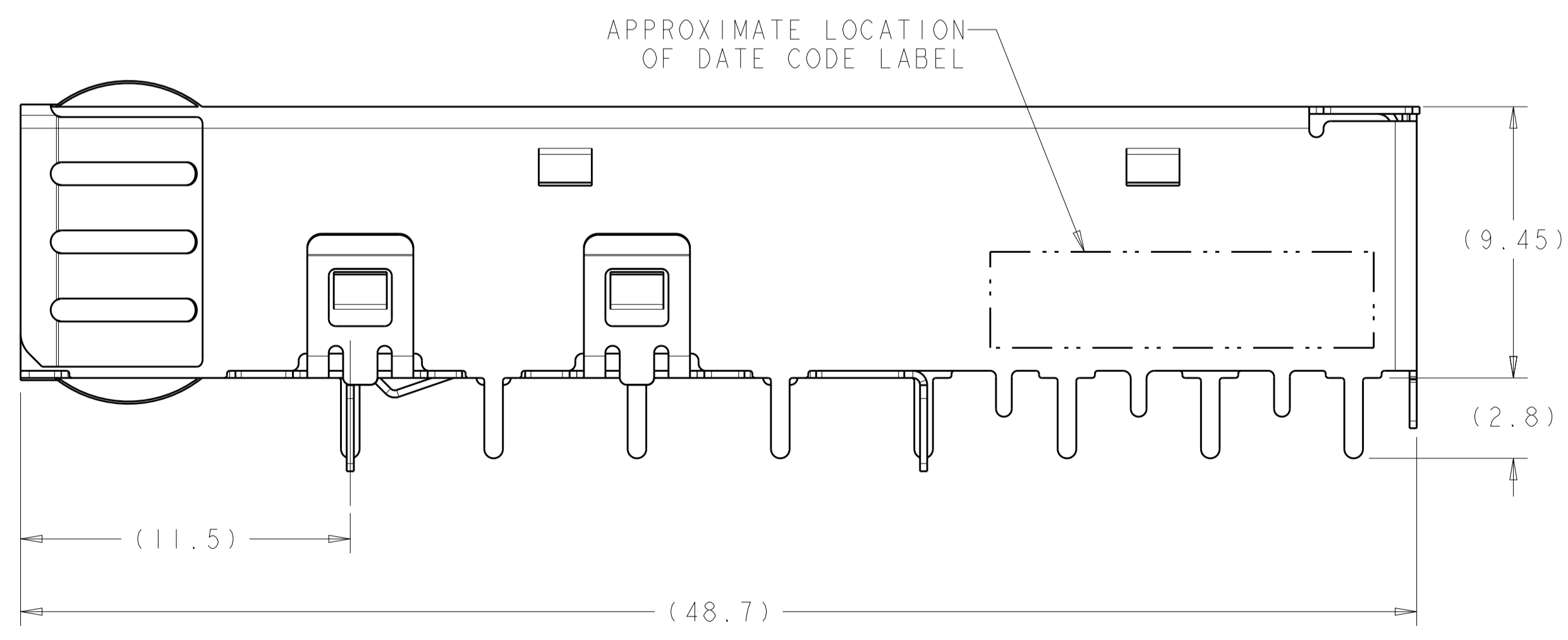
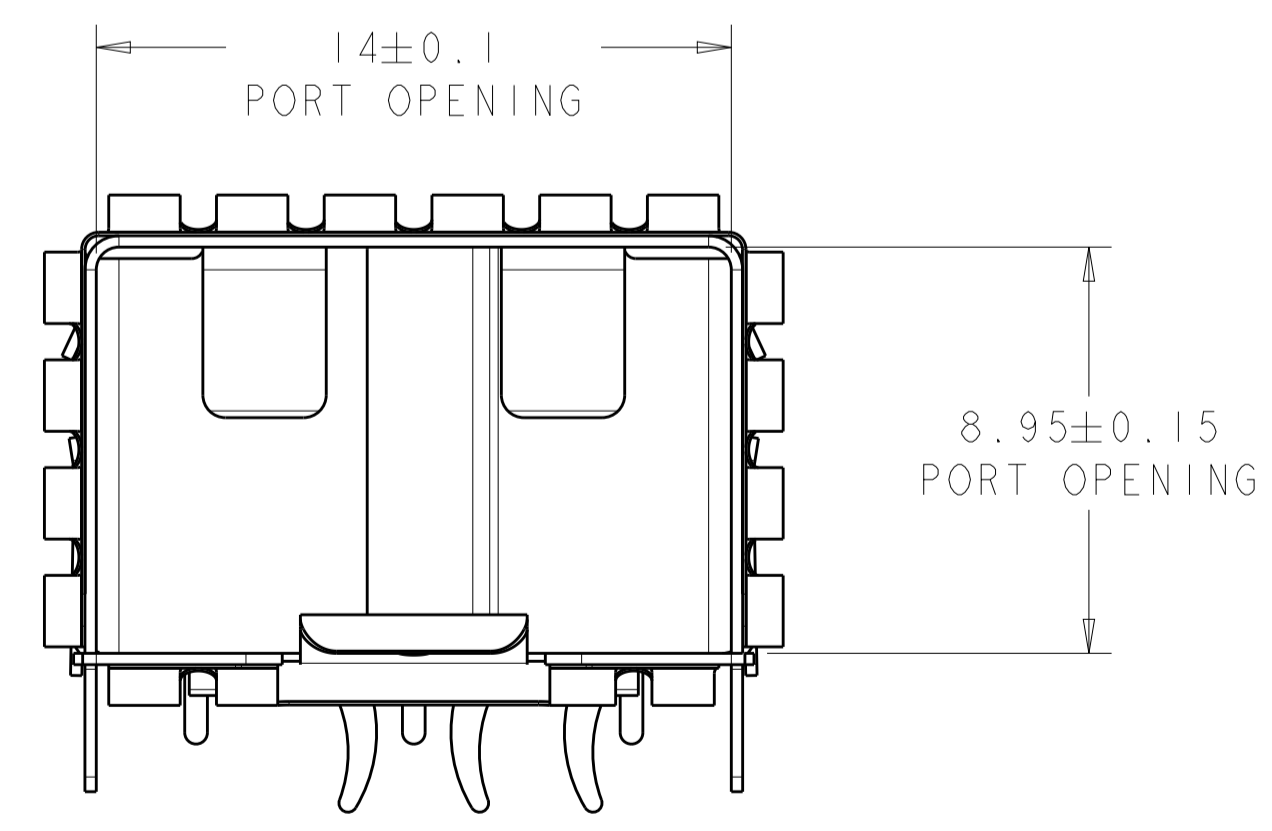

PACKAGE	DESCRIPTION	PART NUMBER
TAPE&REEL	EMI HOLES	2007194-5
TRAY	HEATSINK OPENING	2007194-2
TRAY	EMI HOLES	2007194-1

THIS DRAWING IS A CONTROLLED DOCUMENT.

OWN: Z.M.REAM 10JUL2007
 CHG: M.R.SCHMITT 10JUL2007
 APVD: B.H.WERTZ 10JUL2007

DIMENSIONS: mm
 TOLERANCES UNLESS OTHERWISE SPECIFIED:
 0 PLC ±0.1
 1 PLC ±0.1
 2 PLC ±0.1
 3 PLC ±0.05
 4 PLC ±0.05
 ANGLES ±0.05

MATERIAL: FINISH:

PRODUCT SPEC: 108-2364
 APPLICATION SPEC: 114-13120
 WEIGHT: -
 CUSTOMER DRAWING

STE TE Connectivity

NAME: SFP+ IXI CAGE ASSEMBLY, PCI, SOLDER TAILS, EXTERNAL EMI SPRINGS

SIZE: A1 CAGE CODE: 100779 DRAWING NO: 2007194 RESTRICTED TO: 2

SCALE: 6:1 SHEET: 1 OF 2 REV: D2

LOC	DIST	REV	DATE	BY	APPV
GP	00				

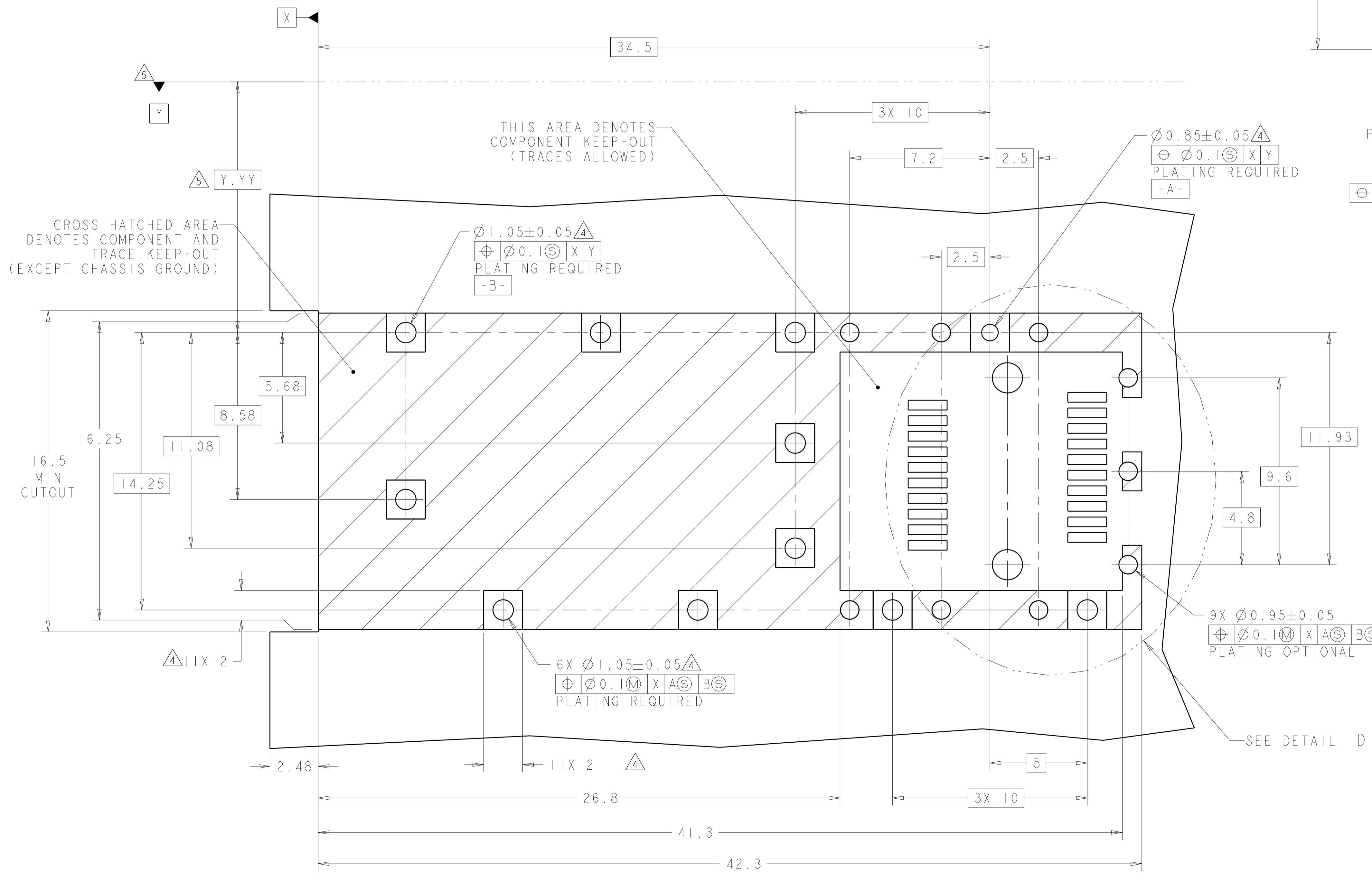
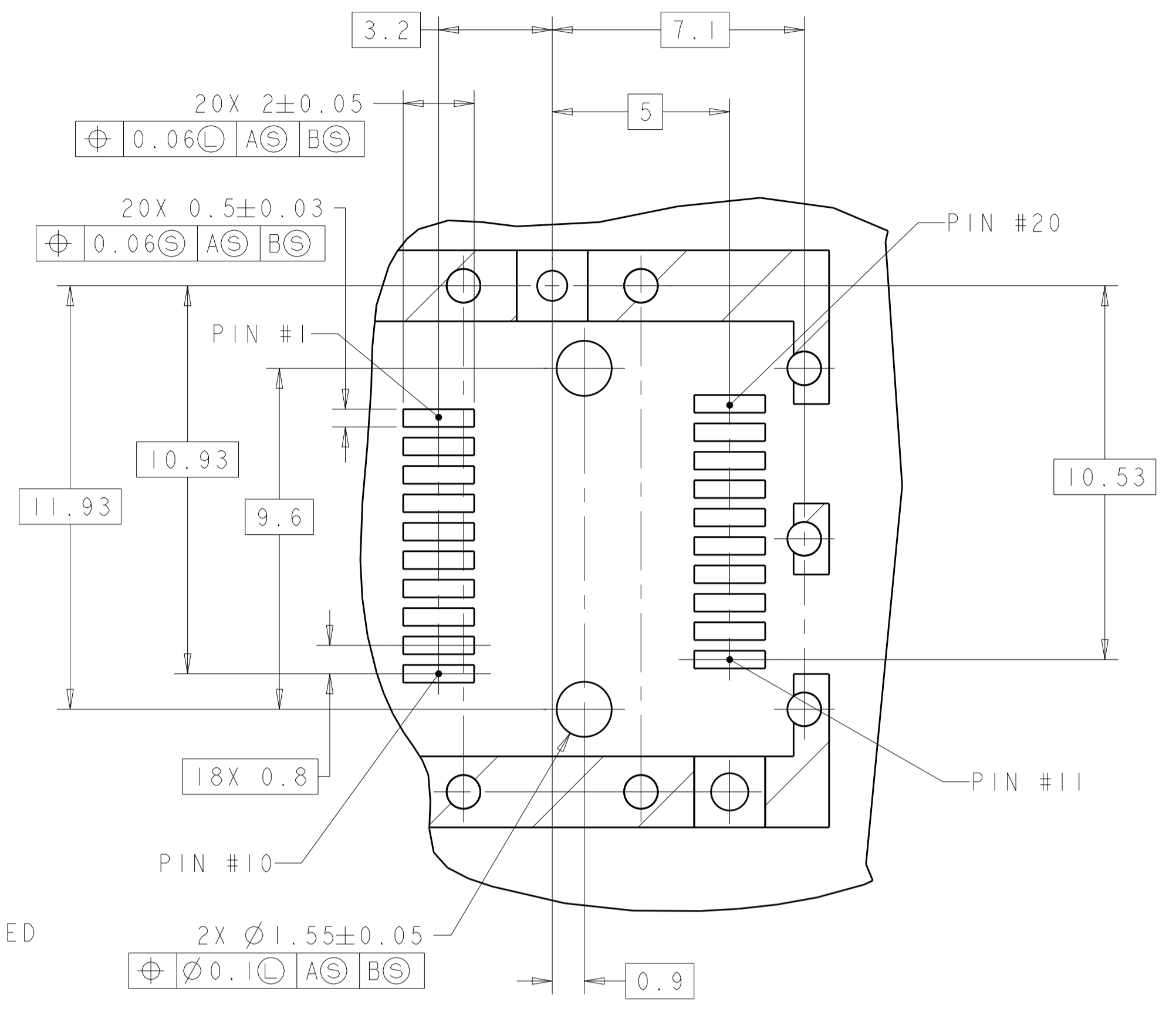
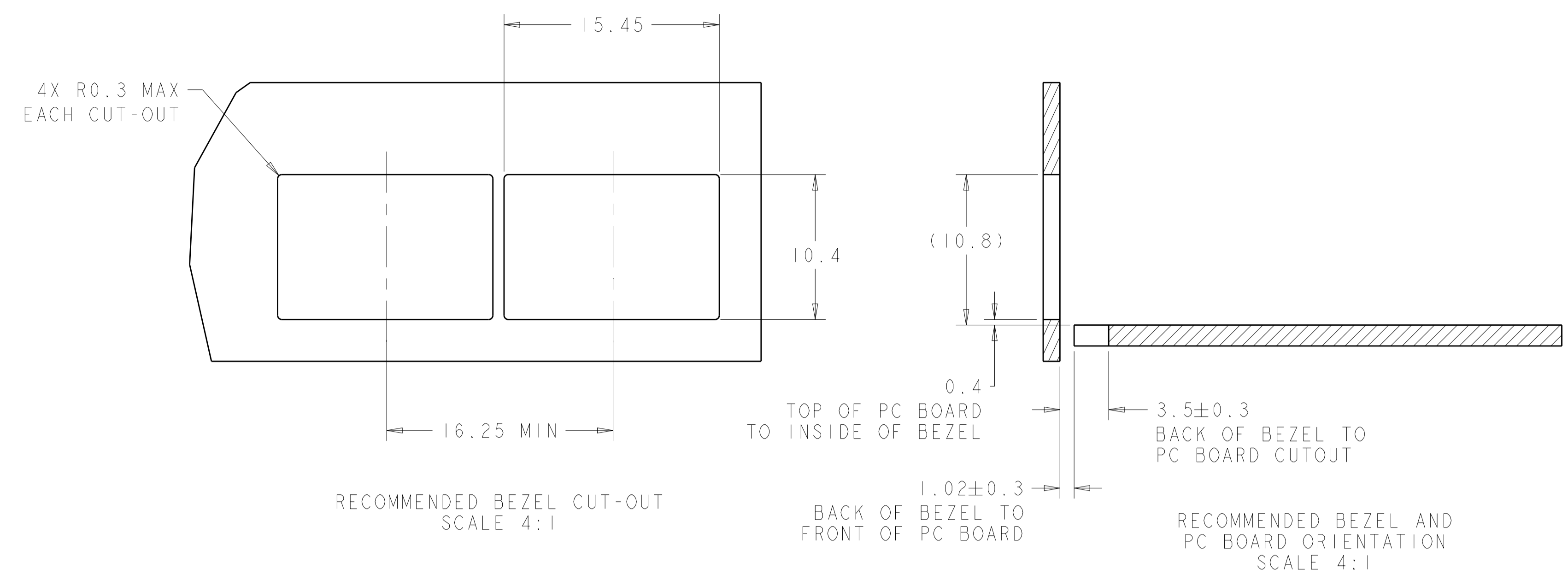

勝特力電材超市-龍山店 886-3-5773766
 勝特力電材超市-光復店 886-3-5729570
 勝特力电子(上海) 86-21-34970699
 勝特力电子(深圳) 86-755-83298787
<http://www.100y.com.tw>

THIS DRAWING IS A CONTROLLED DOCUMENT.		OWN Z. M. BEAM	10JUL2007	TE Connectivity
DIMENSIONS: mm		CHK M. B. SCHMITT	10JUL2007	
TOLERANCES UNLESS OTHERWISE SPECIFIED:		APVD B. H. WERTZ	10JUL2007	NAME SFP+ 1X1 CAGE ASSEMBLY, PCI, SOLDER TAILS, EXTERNAL EMI SPRINGS
0 PLC	±0.1	PRODUCT SPEC		SIZE 108-2364
2 PLC	±0.1	APPLICATION SPEC		RESTRICTED TO
3 PLC	±0.1	114-13120		A100779C=2007194
4 PLC	±0.05	WEIGHT		SCALE 6:1 SHEET 2 OF 2 REV D2
ANGLES	±0.05	CUSTOMER DRAWING		