

THIS DRAWING IS UNPUBLISHED.

RELEASED FOR PUBLICATION

20

© COPYRIGHT 20 BY -

ALL RIGHTS RESERVED.

REVISIONS

P	LTR	DESCRIPTION	DATE	DWN	APVD
	A	RELEASED	23MAR2021	Y.O	E.I

1. TECHNICAL CHARACTERISTICS:
 CONTACT MATERIAL: Cu ALLOY
 SURFACE PLATING:
 GOLD PLATING: 0.2μmMIN

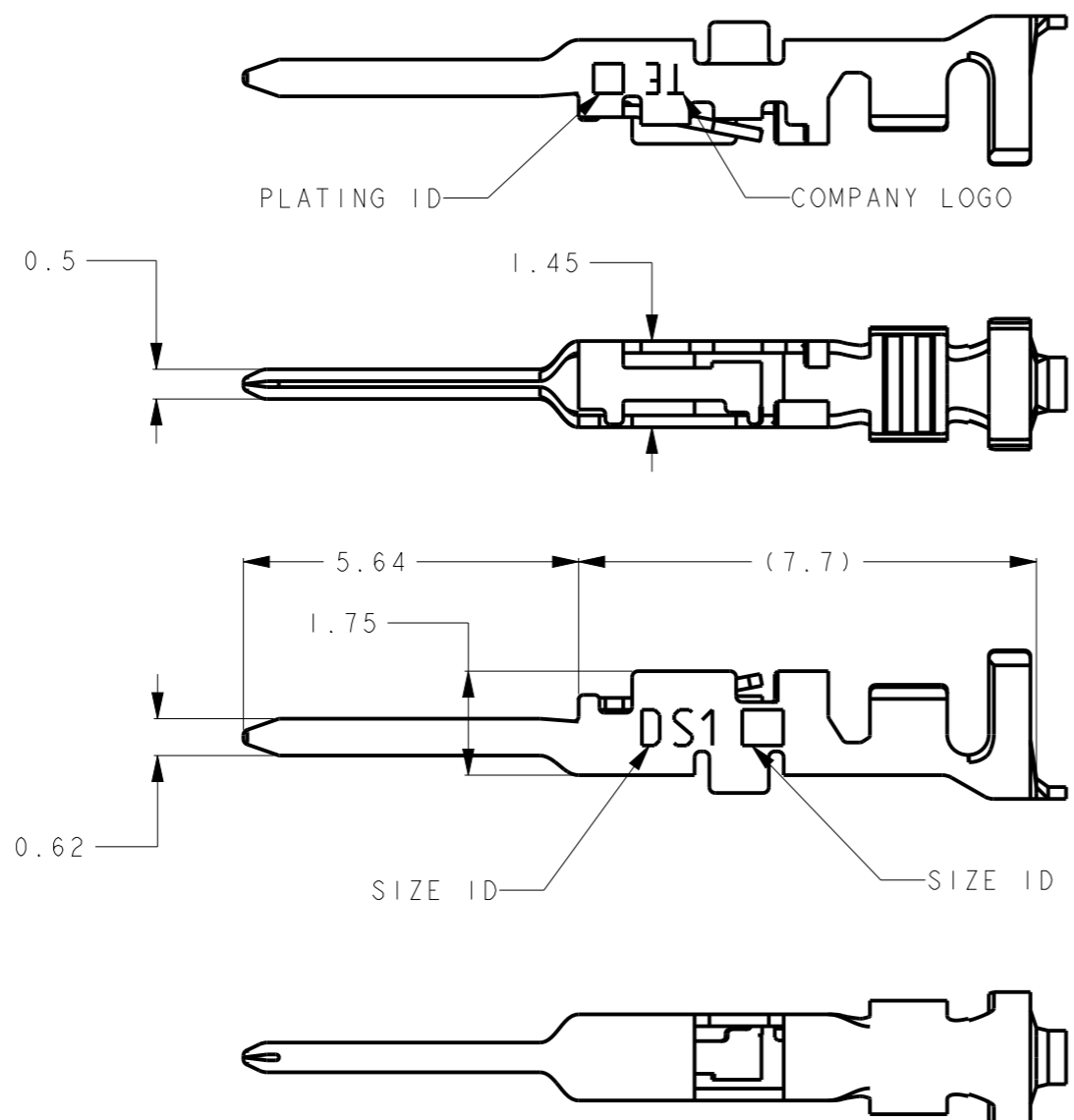

勝特力電材超市-龍山店 886-3-5773766
 勝特力電材超市-光復店 886-3-5729570
 勝特力電子(上海) 86-21-34970699
 勝特力電子(深圳) 86-755-83298787
<http://www.100y.com.tw>

0.1g	M	I	1.08-1.6	AWG28-22, 0.08-0.37SQmm	M SIZE, GOLD 0.2μm	2367820-2
0.1g	S	I	0.6-1.2	AWG30-28, 0.05-0.1SQmm	S SIZE, GOLD 0.2μm	2367820-1
NET WEIGHT	SIZE ID	PLATING ID	INSUL. RANGE	WIRE RANGE	DESCRIPTION	PART NO

THIS DRAWING IS A CONTROLLED DOCUMENT.

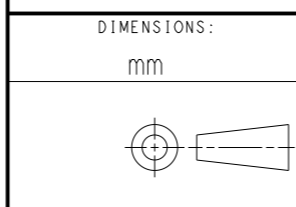

TOLERANCES UNLESS OTHERWISE SPECIFIED:

0 PLC	±0.5
1 PLC	±0.5
2 PLC	±0.5
3 PLC	±0.5
4 PLC	±0.5
ANGLES	±3°

MATERIAL	FINISH
-	-
-	-

DWN	Y. OKADA	13APR2020
CHK	T. SHIMOYASU	13APR2020
APVD	F. IKEMATSU	13APR2020
PRODUCT SPEC	108-140257	
APPLICATION SPEC	114-5377	
WEIGHT	-	
CUSTOMER DRAWING		

STE TE Connectivity			
NAME TAB CONTACT, D1000 SLIM, DYNAMIC			
SIZE	CAGE CODE	DRAWING NO	RESTRICTED TO
A3	-	©-2367820	-
SCALE 8:1		SHEET 1 OF 1	REV A

Crimping requirements for DYNAMIC 1000 Series contacts

1. SCOPE

This Application specification covers the crimping requirements for DYNAMIC 1000 Series contacts

2. APPLICABLE PRODUCT PART NUMBER

See Fig.1.

Contact Type	Size	Contact Part number L/P: Loose Piece	Plating Finish	Wire Size (AWG# REF) [mm ²]	Insulation Diameter [mm]
Receptacle Contact	S	1827569-2/ *- 2367817-1 [b] : Reel	Gold Plating	0.05~0.10 (#30~#28)	φ 0.60~ φ 1.20
		1827586-2/ *-2367818-1 [b] : L/P			
	M	1827570-2/ *-2367817-2 [b] : Reel	Gold Plating	0.08~0.37 (#28~#22)	φ 1.08~ φ 1.60
		1827587-2/ *-2367818-2 [b] : L/P			
		1939991-2 : Reel	Gold 0.76Plating		
		1939992-2 : L/P			
		1871303-1 : Reel			
	1871743-1 : L/P				
	L [a]	1827571-2 : Reel	Gold Plating	0.08~0.37 (#28~#22)	φ 1.08~ φ 1.90
		1827588-2 : L/P	Tin Plating		
		1871304-1 : Reel			
	2L [a]	1871744-1 : L/P			
		1827572-2 : Reel	Gold Plating	0.34~0.87 (#22~#18)	φ 1.40~ φ 2.20
		1827589-2 : L/P	Tin Plating		
		1871731-1 : Reel			
	1871745-1 : L/P				
	S	1903111-2/ *-2367819-1 [b] : Reel	Gold Plating	0.05~0.10 (#30~#28)	φ 0.60~ φ 1.20
		1903115-2/ *-2367820-1 [b] : L/P			
	M	1903112-2/ *-2367819-2 [b] : Reel	Gold Plating	0.08~0.37 (#28~#22)	φ 1.08~ φ 1.60
		1903116-2/ *-2367820-2 [b] : L/P			
		1903120-1 : Reel	Tin Plating		
		1903124-1 : L/P			
	L [a]	1903113-2 : Reel	Gold Plating	0.08~0.37 (#28~#22)	φ 1.08~ φ 1.90
		1903117-2 : L/P	Tin Plating		
		1903121-1 : Reel			
		1903125-1 : L/P			
	2L [a]	1903114-2 : Reel	Gold Plating	0.34~0.87 (#22~#18)	φ 1.40~ φ 2.20
		1903118-2 : L/P	Tin Plating		
		1903122-1 : Reel			
		1903126-1 : L/P			

Fig.1

[a]. L and 2L size are not applicable for D1100 (2.0mm Pitch) housings.

[b]. D1000 Slim Contact. It is applicable for D1000 slim housings.

3. Crimping REQUIREMENTS

See Fig.2 and Fig.3

NO.	Check Item	Specified Requirements	NO.	Check Item	Specified Requirements
①	Wire Stripping Length	2mm±0.3	⑥	Twisting	3° Max
②	Cut-Off Tab Length	0.25mm Max	⑦	Rolling	5° Max
③	Rear Bell mouth Length	0.1~0.3mm	⑧	Wire-End Protrusion Length	0.1~0.65mm
④	Bend-Up	3° Max	⑨ 【c】	Insulation Barrel Width	See Fig.4, 5
⑤	Bend-Down	3° Max	⑩ 【c】	Insulation Barrel Height	See Fig.4, 5

【c】. Insulation barrel crimping dimension ⑨ and ⑩ should be controlled under Fig.5 and Fig.6 not to interfere housings.

Fig 2

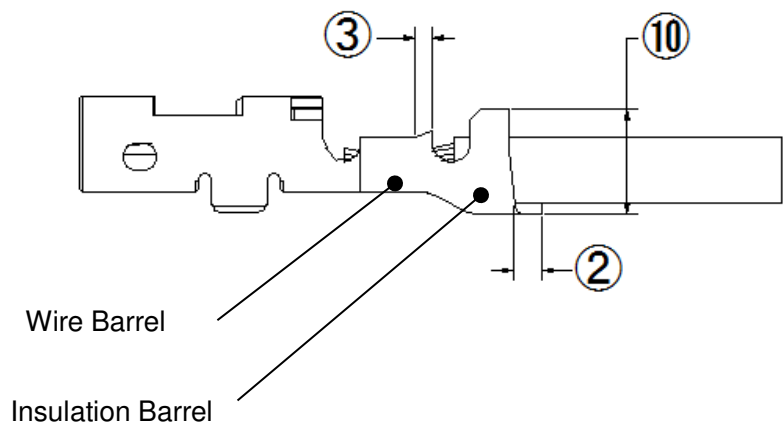
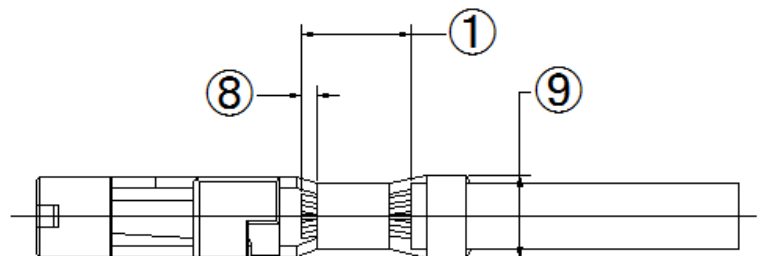

Fig 3

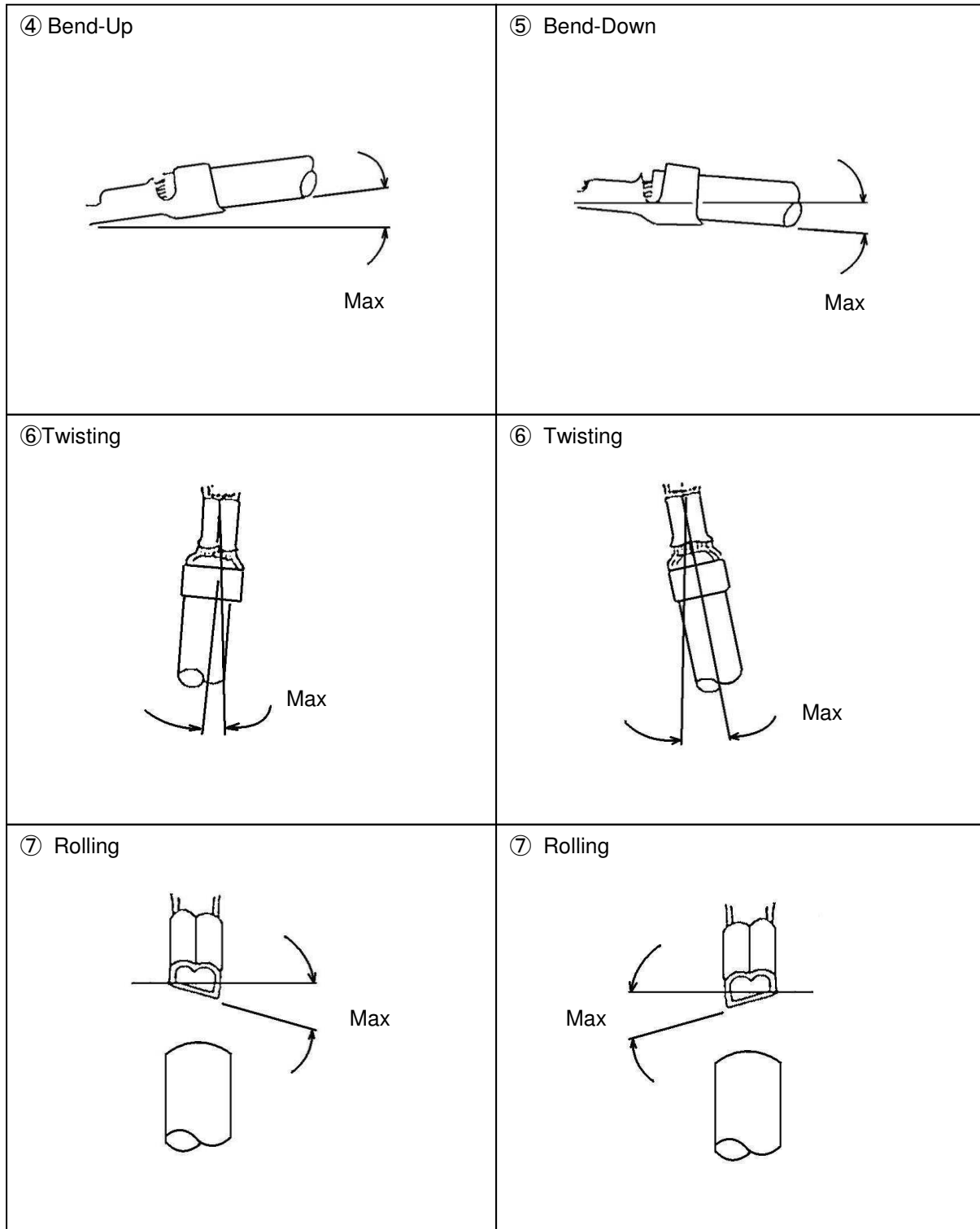

Fig.4

4. CRIMPING DATA

4.1 Applicator

See Fig.5

Reel Contact Part No	Applicator Number	Wire Size		Insulation Stripping Length [mm]	Wire Crimp		Insulation		Finished Insulation Diameter [mm]	Crimp Tensile Strength [Kg MIN]	
		No. of Conductor [e]	Cross Section [mm ²] (AWG) [f]		Width [mm]	Crimp Height [mm]	⑨ Barrel Width [mm]	⑩ Crimp Height [mm]			
D1000 contact [g]											
S	1827569-2 1903111-2	2151110-1	1	0.05~ 0.06(#30)	2.0±0.3	0.90 (REF)	0.54±0.03	1.5MAX " F "	1.4~ 1.8MAX	φ0.60~ φ1.20	0.5
			1	0.08~ 0.10(#28)			0.57±0.03				1.0
M	1827570-2 1871303-1 1903112-2 1903120-1 1939991-2	2151082-1	1	0.08~ 0.10(#28)	2.0±0.3	1.16 (REF)	0.64±0.03	1.5MAX " F "	1.6~ 2.2MAX	φ1.08~ φ1.60	1.0
			1	0.12~ 0.15(#26)			0.67±0.03				2.0
			1	0.21~ 0.23(#24)			0.73±0.03				3.0
			1	0.34~ 0.37(#22)			0.80±0.03				4.5
L [d]	1827571-2 1871304-1 1903113-2 1903121-1	2151111-1	1	0.08 0.10(#28)	2.0±0.3	1.16 (REF)	0.64±0.03	2.1MAX " F "	1.6~ 2.4MAX	φ1.08~ φ1.90	1.0
			1	0.12~ 0.15(#26)			0.67±0.03				2.0
			1	0.21~ 0.23(#24)			0.73±0.03				3.0
			1	0.34~ 0.37(#22)			0.80±0.03				4.5
2L [d]	1827572-2 1871731-1 1903114-2 1903122-1	2151083-1	1	0.34~ 0.37(#22)	2.0±0.3	1.40 (REF)	0.85±0.03	2.1MAX " F "	2.0~ 2.4MAX	φ1.40~ φ2.20	4.5
			1	0.51~ 0.53(#20)			1.00±0.03				6.5
			1	0.85~ 0.87(#18)			1.15±0.03				6.5
D1000 Slim contact [g]											
S	*-2367817-1 *-2367819-1	2151110-1	1	0.05~ 0.06(#30)	2.0±0.3	0.90 (REF)	0.49-0.55	1.5MAX " F "	1.4~ 1.8MAX	φ0.60~ φ1.20	0.5
			1	0.08~ 0.10(#28)			0.52-0.57				1.0
M	*-2367817-2 *-2367819-2	2151082-1	1	0.08~ 0.10(#28)	2.0±0.3	1.16 (REF)	0.64±0.03	1.5MAX " F "	1.6~ 2.2MAX	φ1.08~ φ1.60	1.0
			1	0.12~ 0.15(#26)			0.67±0.03				2.0
			1	0.21~ 0.23(#24)			0.73±0.03				3.0
			1	0.34~ 0.37(#22)			0.80±0.03				4.5

See Fig.5

[d]. L and 2L size are not applicable for D1100 (2.0mm Pitch) housings

[e]. The contacts are not applicable for crimping multi wires. The strand diameter should be over ϕ 0.1mm.

[f]. Solid wire is not applied.

[g]. After crimped, check that the crimped sample can be inserted into the housing.

2 Hand Tool

See Fig.6

Loose Piece Contact Part No	Hand Tool Number	Wire Size		Insulation Stripping Length [mm]	Wire Crimp		Insulation		Finished Insulation Diameter [mm]	Crimp Tensile Strength [Kg MIN]		
		No. of Conductor [i]	Cross Section [mm ²] (AWG) [j]		Width [mm]	Crimp Height [mm]	⑨ Barrel Width [mm]	⑩ Crimp Height [mm]				
D1000 contact [i]												
S 1827586-2 1903115-2	2119144-1	1	0.05~ 0.06(#30)	2.0±0.3	0.90 (REF)	0.49~0.59	1.5MAX " F "	1.3(REF)	φ0.60~ φ1.00	0.5		
		1	0.08~ 0.10(#28)			0.52~0.62					1.5(REF)	φ0.80~ φ1.20
M 1827587-2 1871743-1 1903116-2 1903124-1 1939992-2	2119141-1	1	0.08~ 0.10(#28)	2.0±0.3	1.16 (REF)	0.59~0.69	1.5MAX " F "	1.95(REF)	φ1.08~ φ1.40	1.0		
		1	0.12~ 0.15(#26)			0.59~0.69					2.0	
		1	0.21~ 0.23(#24)			0.69~0.79				2.1(REF)		φ1.20~ φ1.60
		1	0.34~ 0.37(#22)			0.69~0.79				4.5		
L [h] 1827588-2 1871744-1 1903117-2 1903125-1	2119143-1	1	0.08~ 0.10(#28)	2.0±0.3	1.16 (REF)	0.59~0.69	2.1MAX " F "	2.05(REF)	φ1.08~ φ1.40	1.0		
		1	0.12~ 0.15(#26)			0.59~0.69					2.0	
		1	0.21~ 0.23(#24)			0.69~0.79		2.2(REF)	φ1.20~ φ1.90	3.0		
		1	0.34~ 0.37(#22)			0.69~0.79		4.5				
2L [h] 1827589-2 1871745-1 1903118-2 1903126-1	2119142-1	1	0.34~ 0.37(#22)	2.0±0.3	1.40 (REF)	0.80~0.90	2.1MAX " F "	2.1(REF)	φ1.40~ φ2.00	4.5		
		1	0.51~ 0.53(#20)			0.80~0.90					6.5	
		1	0.85~ 0.87(#18)			1.10~1.20		2.4(REF)	φ1.80~ φ2.20	6.5		
D1000 Slim contact [i]												
S *-2367818-1 *-2367820-1	2381707-2 [m]	1	0.05~ 0.06(#30)	2.0±0.3	0.90 (REF)	0.49-0.55	1.5MAX " F "	1.3(REF)	φ0.60~ φ1.00	0.5		
	2381707-2 [n]	1	0.08~ 0.10(#28)			0.52-0.57					1.5(REF)	φ0.80~ φ1.20
M *-2367818-2 *-2367820-2	2381748-1 (2119141-1 with 2381710-1) [k]	1	0.08~ 0.10(#28)	2.0±0.3	1.16 (REF)	0.59~0.69	1.5MAX " F "	1.95(REF)	φ1.08~ φ1.40	1.0		
		1	0.12~ 0.15(#26)			0.59~0.69					2.0	
		1	0.21~ 0.23(#24)			0.69~0.79				2.1(REF)		φ1.20~ φ1.60
		1	0.34~ 0.37(#22)			0.69~0.79				4.5		

Fig.6

[h]. L and 2L size are not applicable for D1100 (2.0mm Pitch) housings

[i]. The contacts are not applicable for crimping multi wires. The strand diameter should be over ϕ 0.1mm.

[j]. Solid wire is not applied.

[k]. Apply to use D1000 Hand tool with 2381710-1 by exchange flip locator

[l]. After crimped, check that the crimped sample can be inserted into the housing.

[m]. 2119144-1 with 2381710-1 can be used for crimping if it can be crimped with crimp height 0.49-0.55 mm

[n]. 2119144-1 with 2381710-1 can be used for crimping if it can be crimped with crimp height 0.52-0.57 mm