



**NOTE**

All numerical values are in metric units [with U.S. customary units in brackets]. Dimensions are in millimeters. Unless otherwise specified, dimensions have a tolerance of  $\pm 0.13$  and angles have a tolerance of  $\pm 2^\circ$ . Figures are not drawn to scale.

## 1. INTRODUCTION

This specification covers the requirements for application of Mini Dynamic Receptacle Terminals. The terminal features a wire barrel with serrations that help hold the wire in place after termination, insulation barrel, and locking lance. The locking lance secures the terminal in the housing after insertion. The terminals are supplied on reels for terminating using an automatic machine.

Basic terms and features of this product are provided in Figure 1.

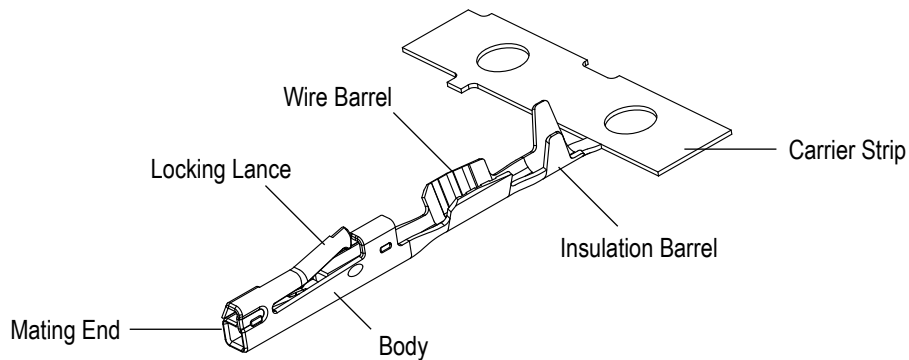

Figure 1

## 2. REFERENCE MATERIAL

### 2.1. Revision Summary

Initial release of application specification

### 2.2. Customer Assistance

Reference Product Base Part Number 2834464 is representative of Mini Dynamic female terminals. Use of these numbers will identify the product line and help you to obtain information when visiting [www.te.com](http://www.te.com).

Mating header side, Base part number is 2834465.

### 2.3. Drawings

Customer drawings for product part numbers are available from [www.te.com](http://www.te.com). Information contained in the customer drawing takes priority.

### 2.4. Specifications

Product specification [108-137443](#) provides product performance and test results.

勝特力電材超市-龍山店 886-3-5773766  
勝特力電材超市-光復店 886-3-5729570  
勝特力电子(上海) 86-21-34970699  
勝特力电子(深圳) 86-755-83298787  
<http://www.100y.com.tw>

### 3. REQUIREMENTS

#### 3.1. Safety

Do not stack product shipping containers so high that the containers buckle or deform.

#### 3.2. Storage

##### A. Ultraviolet Light

Prolonged exposure to ultraviolet light may deteriorate the chemical composition used in the product material.

##### B. Shelf Life

The product should remain in the shipping containers until ready for use to prevent deformation to components. The product should be used on a first in, first out basis to avoid storage contamination that could adversely affect performance.

##### C. Chemical Exposure

Do not store product near any chemical listed below as they may cause stress corrosion cracking in the material.

Alkalis	Ammonia	Citrates	Phosphates	Citrates	Sulfur Compounds
Amines	Carbonates	Nitrites	Sulfur Nitrites		Tartrates

#### 3.3. Wire Selection and Preparation

Wire sizes, type, and strip length for these terminals is given Figure 2. For advice on other wire, contact the number at the bottom of page 1.



**CAUTION**

*Individual wire strands must not be bent or cut off during the stripping operation.*

WIRE			
CONDUCTOR SIZE	INSULATION DIAMETER	TYPE	STRIP LENGTH
		DESCRIPTION	
0.13 mm <sup>2</sup> --- 0.17mm <sup>2</sup>	0.85---1.10 mm	FLU and FLR according with ISO 6722-1 ● or UL 1061 (7 strands both)	
0.22 mm <sup>2</sup> --- 0.35 mm <sup>2</sup>	0.95---1.30 mm	FLU and FLR according with ISO 6722-1 ● or UL 1061 (7 strands both)	

● Recommended

Figure 2

#### 3.4. Crimp

The crimped terminal must conform to the following requirements.

##### A. Cutoff Tab

The cutoff tab is the remaining portion of the carrier strip after the terminal is cut from the strip. The cutoff tab must not be bent away from the wire insulation and must not exceed the dimension given in Figure 3.

##### B. Burr

Any burr on the base of the wire barrel crimp or insulation barrel crimp must not exceed the dimension given in Figure 3.

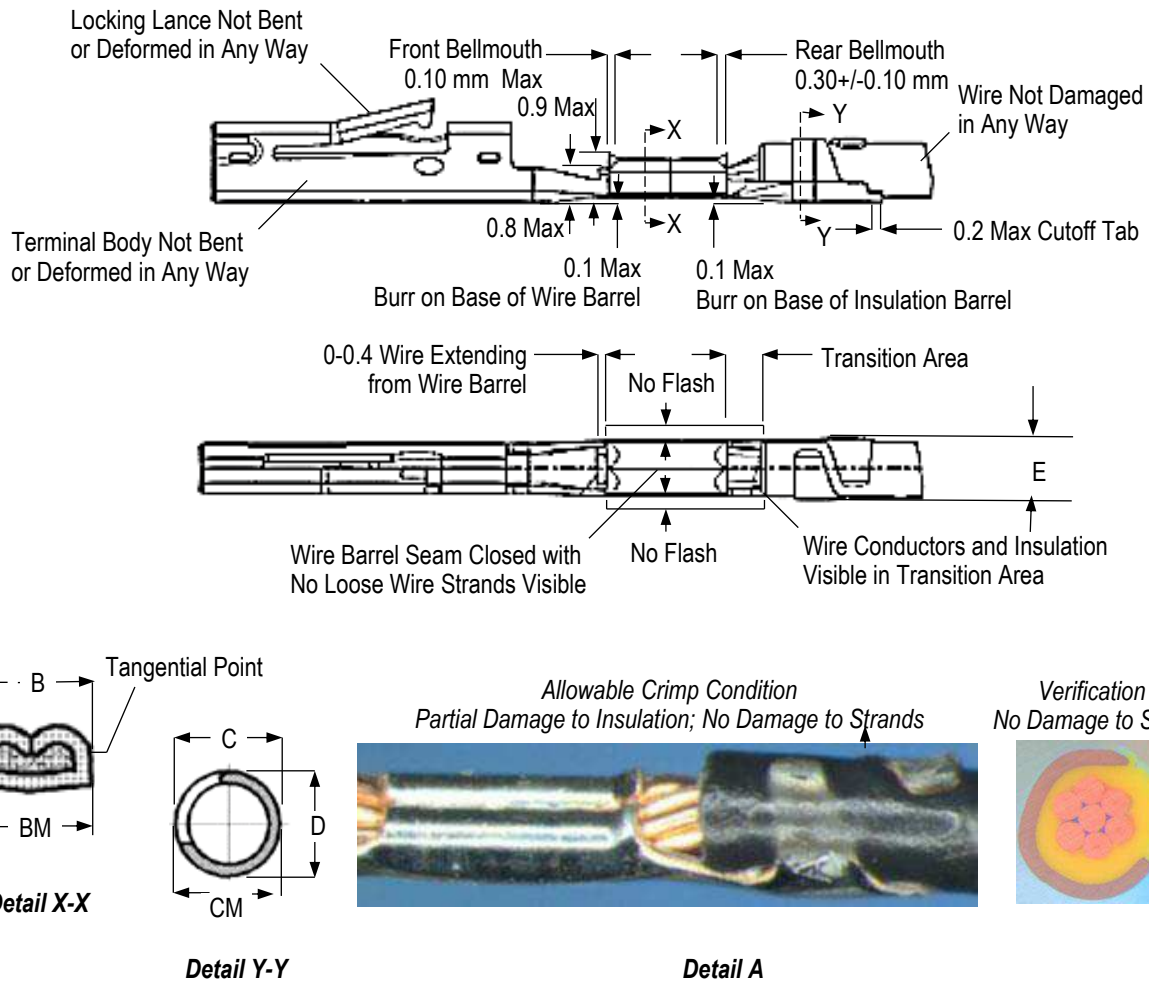

WIRE		TERMINAL										
CONDUCTOR SIZE	INSULATION DIAMETER	WIRE BARREL CRIMP DIMENSION				INSULATION BARREL CRIMP DIMENSION						
		A HEIGHT ±0.02	B WIDTH REF	BM WIDTH	TYPE	C WIDTH REF	CM WIDTH	D HEIGHT MAX	TYPE	E MAX		
0.13 mm <sup>2</sup> *	0.85-1.10	0.59	0.89	0.89-0.99	F-Crimp	1.07	1.07-1.17	1.40	Wrap	1.20		
0.17 mm <sup>2</sup> *		0.63						1.40		1.20		
0.22 mm <sup>2</sup>	0.95-1.30	0.64	1.07	1.07-1.18				1.27		1.27-1.40	1.40	1.40
0.35 mm <sup>2</sup>		0.72									1.40	1.40

Figure 3

\* For wire sizes 0.13-0.17mm<sup>2</sup> on machines an additional small wire gauge kit for wire handling may be necessary. Please ask machine manufacturer.

### C. Wire Barrel Crimp

The wire barrel must have an F-crimp termination. All conductors must be held firmly inside the wire barrel. The crimped area must be symmetrical on both sides of the wire barrel. The crimp may be off center on the wire barrel but not off the end of the wire barrel. The crimp height and width must be within the dimensions provided in Figure 3.

#### D. Insulation Barrel Crimp

The wire insulation shall not be cut or broken during the crimping operation. For wires having insulation diameter greater than 1, partial damage of the insulation from the terminal crimp may occur. This is allowed as long as there is no damage to the wire strands. Refer to Figure 3, Detail A.

No strands can be folded back over the wire insulation. The insulation barrel must have a wrap crimp termination. The wire insulation must be inside the insulation barrel and must not enter the wire barrel. The crimp height and width must be within the dimensions provided in Figure 3.



#### NOTE

The insulation barrel crimp width and height should be measured using a standard micrometer with flat surfaces. A bend test in accordance with DIN standard 41611, "Solderless Electrical Connections," is recommended. The insulation must not come loose after one bend cycle.

#### E. Terminal Body and Locking Lance

The terminal body and locking lance must not be bent or deformed in any way.

#### F. Bellmouths

The front and rear bellmouths must be within the dimensions given in Figure 3.

#### G. Flash

A bulging of the terminal material at the outside of the terminal from the terminal body to the insulation barrel is not allowed.

#### H. Transition Area

Both wire conductors and insulation must be visible in the transition area (between the wire barrel and insulation barrel). The width of the transition area must be no more than the dimension given in Figure 3.

#### I. Wire Barrel Seam

The seam between the two sides of the wire barrel must be completely closed and there must be no evidence of loose wire strands or wire strands visible in the seam.

#### J. Wire Extension

Wire ends must be flush with the end of the wire barrel or extend no more than the dimension given in Figure 3.

#### K. Bend Allowance

The bend allowance between the wire barrel and wire is acceptable within the limits given in Figure 4.

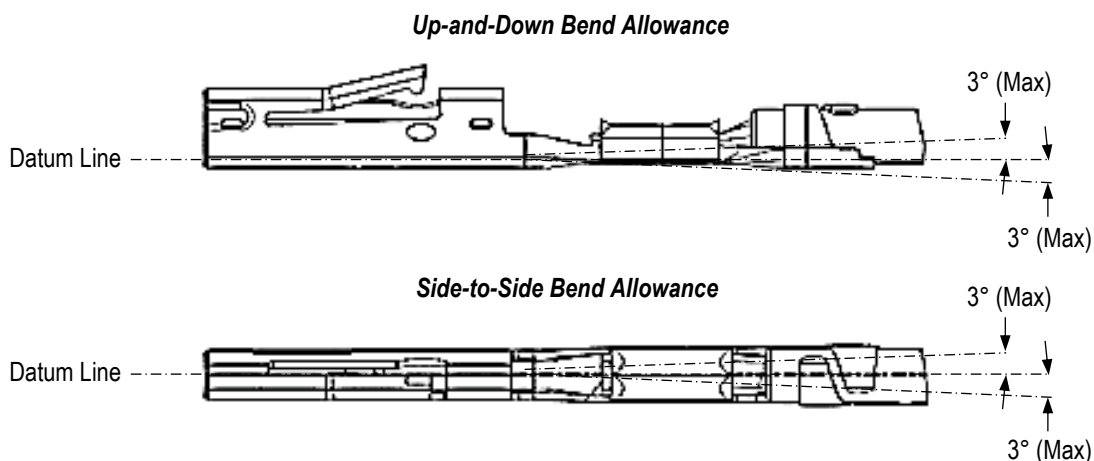

Figure 4

### 3.5. Replacement and Repair

Damaged or defective terminals must be replaced. These terminals cannot be repaired.

### 4. VISUAL AID

The illustration below shows a typical application of mini dynamic connector female terminals. This illustration should be used by production personnel to ensure a correctly applied product. Applications which do not appear correct should be inspected using the information in the preceding pages of this specification and in the instructional material shipped with the product or tooling.

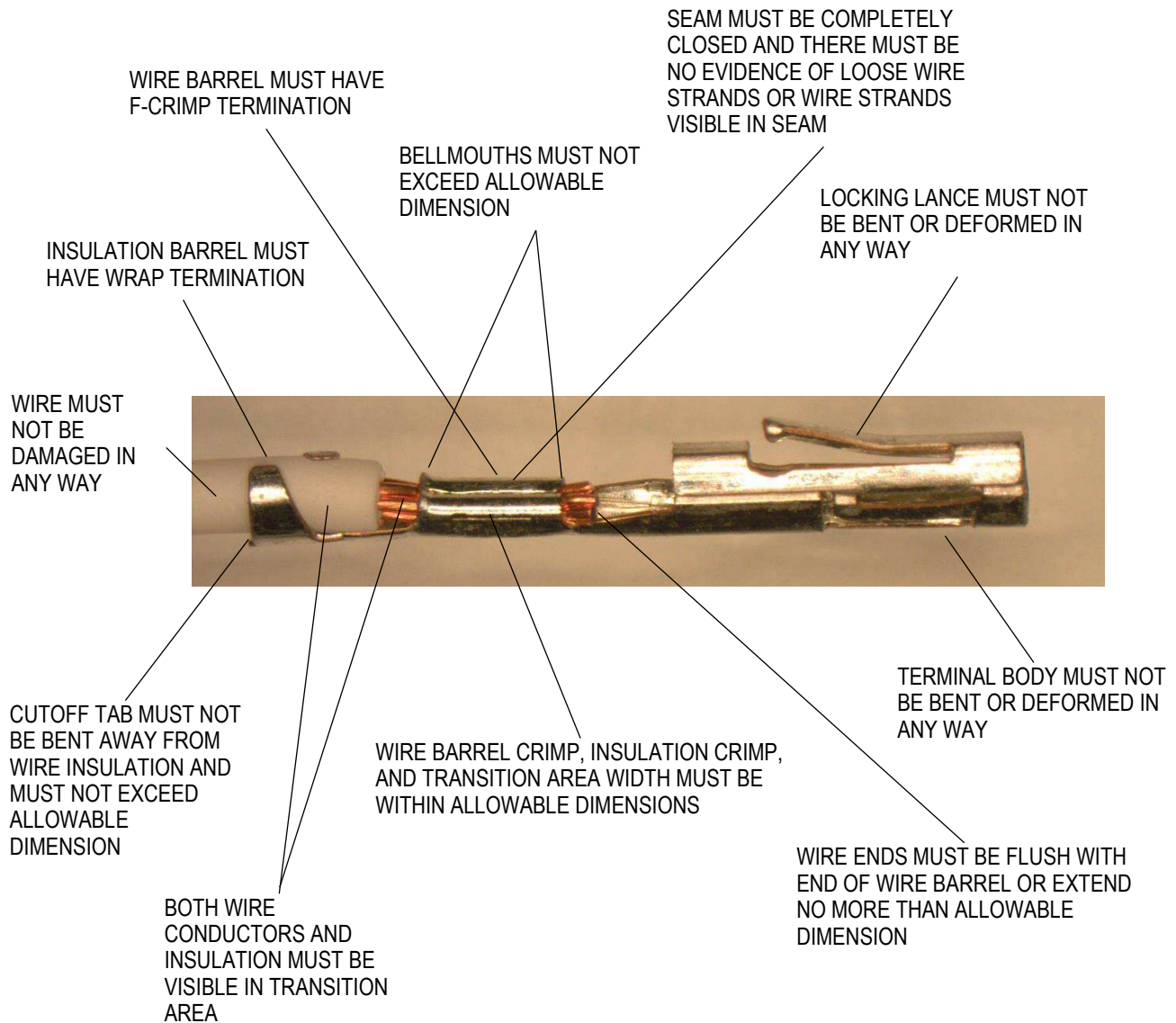

**FIGURE 5. VISUAL AID**

勝特力電材超市-龍山店 886-3-5773766  
 勝特力電材超市-光復店 886-3-5729570  
 勝特力電子(上海) 86-21-34970699  
 勝特力電子(深圳) 86-755-83298787  
<http://www.100y.com.tw>