

Figure 1

1. INTRODUCTION

Extraction Tool 318813-1, shown in Figure 1, is designed to remove the Size 8 straight and right-angle coaxial contacts and AMPLIMITE* power contacts listed in Figure 2 from connector housings. Read these instructions thoroughly before attempting to remove any contacts.

CONTACT BASE PART NUMBER	
COAXIAL	POWER
228596-1	211159-1
228604-1	211159-2
228618-1	211161-1
	211161-2
	212007-1
	212008-1
	212013-1
	212014-1

Figure 2

2. DESCRIPTION (Figure 1)

The extraction tool consists of a spring-loaded metal tip with an integral plunger mounted to a plastic handle with an interlock lever. When the interlock lever is depressed, the plunger is held until the contact locking lances are depressed by the tip.

After the lever is released, the plunger is released, permitting the contact to be pushed out the rear of the housing.

3. EXTRACTION PROCEDURE (Figure 3)

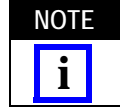

Before extracting coaxial contacts, use a small, sharp tool to remove the nylon alignment ring from the front of the contact.

1. Determine the contact to be removed and grasp the wire attached to that contact.
2. Move the contact forward as far as possible by pushing the wire toward the housing.
3. Depress the extraction tool interlock lever and insert the tip of the tool into the contact cavity in the mating face of the housing. Make sure that the tip is completely bottomed in the cavity.

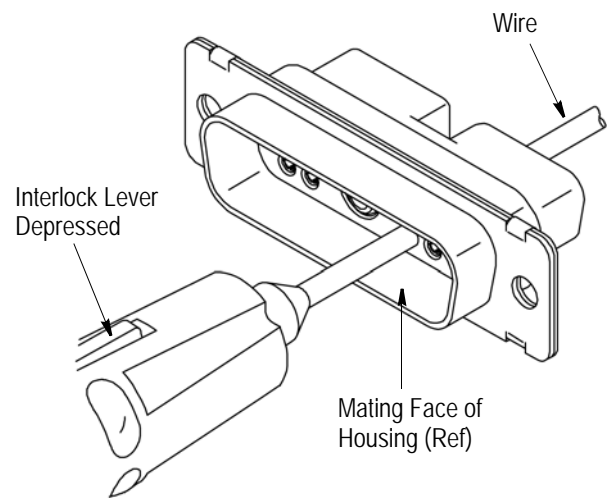

Figure 3

4. While holding the tool in position, release the interlock lever, then push the handle until the contact backs out of the rear of the housing. The wire and contact should pull out of the housing.

4. TOOL MAINTENANCE

It is recommended that the tool be inspected when you receive it and at regularly scheduled intervals. The tool is not repairable and should be replaced when it is worn or damaged. Store the extraction tool in a clean, dry place and clean the extraction tool with a soft, lint-free cloth.

Additional tools can be purchased from:

CUSTOMER SERVICE (038-035)
TYCO ELECTRONICS CORPORATION
PO BOX 3608
HARRISBURG PA 17105-3608

5. REVISION SUMMARY

Since the previous release of this document, the new company logo has been applied.