

勝特力材料 886-3-5753170
 勝特力电子(上海) 86-21-34970699
 勝特力电子(深圳) 86-755-83298787
 Http://www.100y.com.tw

Cap Housing

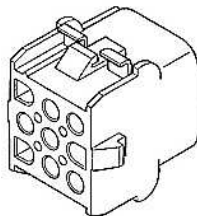

Twist and Lock Cap Housing

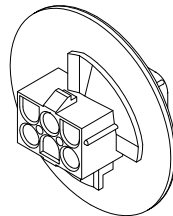

Cap Housing
 Meets GWT and UL 94 V-O Requirements

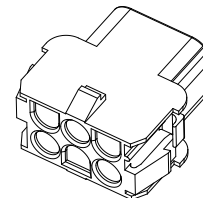

Plug Housing

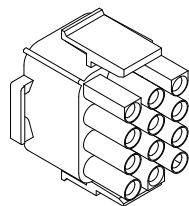

Plug Housing
 Meets GWT and UL 94 V-O Requirements

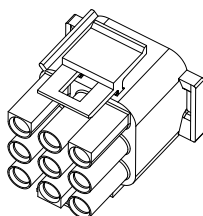

Vertical
 PC Board Header

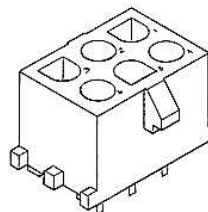

Right-Angle
 PC Board Header

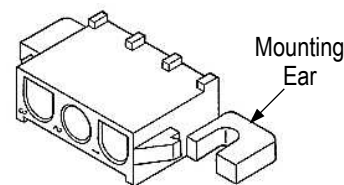

GWT is the glow wire test required by IEC/EN 60335-1

REFERENCE PRODUCT PART NUMBERS

| HOUSING CONNECTOR | | | | | HEADER CONNECTOR | | | |
|-------------------|--------------------|-------------------------|------------|--------------------------|------------------|-------------|-------------|----------|
| CAP | TWIST AND LOCK CAP | CAP (GWT AND UL 94 V-O) | PLUG | PLUG (GWT AND UL 94 V-O) | VERTICAL | | RIGHT-ANGLE | |
| | | | | | PIN | SOCKET | PIN | SOCKET |
| 770421-1 | 794714-1 | 2178773-1 | 1-350867-0 | 1-1863003-2 | 350428-1 | 350759-4 | 1-350942-0 | 643226-1 |
| CONTACT | | | | TEST CONNECTOR | | | | |
| PIN | | SOCKET | | PLUG HOUSING | | CAP HOUSING | | |
| 770672-1 | | 770673-1 | | 350848-2 | | 350849-2 | | |

Figure 1

These instructions cover inserting pin and socket contacts into the cap and plug housings, mating the connectors, using test connectors, mounting the cap housing to a panel, and mounting the header to a printed circuit (pc) board. Reference to instructions for crimping the contacts, installing keying plugs, installing a strain relief, and extracting the contacts is included. Reference product part numbers are given in Figure 1.

For detailed product description and application requirements, refer to application specification 114-1010.

i NOTE
 Dimensions in this instruction sheet are in metric units [with U.S. customary units in brackets]. Figures are not drawn to scale.

Reasons for re-issue of this instruction sheet are provided in Section 4, REVISION SUMMARY.

1. ASSEMBLY

1.1. Inserting Contacts and Keying Plugs (Plug and Cap Housings)

i NOTE
 Split pin contacts are recommended for use in housings having 6, 9, 12, and 15 circuits to reduce mating force. Grounding pin contacts (2.54 mm [.100 in.] longer than standard pin contacts) are designed for a mate first, break last (MFBL) grounding application. Programmable socket contacts are designed to accept 110 series FASTON* receptacle terminals.

1. Ensure that the contacts are crimped to meet the requirements given in [114-1010](#).
2. Observing the cavity identification numbers on the wire end and the No. 1 cavity identification rib on the side of the housing, manually insert each contact into a circuit cavity of the housing. After inserting the terminal into the back of the housing, pull back lightly on the wire of the contact to make sure that the contact is locked in place. If using keying plugs, leave the circuit cavities to be keyed empty. Refer to Figure 2.

For contacts crimped to small wire sizes, insert the contact using extraction tool 455830-1 according to [408-4371](#) (packaged with the tool).

3. If applicable, insert keying plug(s) according to instruction sheet [408-3320](#). Refer to Figure 2.

**NOTE**

Corresponding contact cavity in mating connector must be empty for connectors to engage.

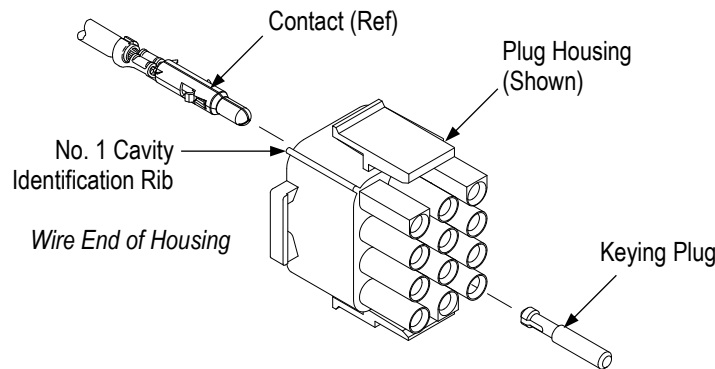

Figure 2

1.2. Strain Relief

Attach the strain relief onto the plug or cap housing according to [408-3320](#).

1.3. Test Connectors

Touch the 2.13 mm [.084 in.] diameter test probe from the applicable test connector onto the socket contact of the plug or cap housing. Follow industry-approved testing procedures.

1.4. Panel Mounting (Cap Housings)

1. Cut a panel having the thickness and dimensions given on [114-1010](#).
2. For the cap housing, insert the cap housing, mating face first, through the panel cutout in the same direction that the cutout was made until the flexible panel mounting latches snap in place. Refer to Figure 3.

For the Twist and Lock cap housing, align the pin 1 indicator rib with the short side polarization opening of the panel, and push the cap housing through the panel. Rotate the cap housing *clockwise* until it is firmly seated. In order to prevent foam leakage, a gap between the cap housing flange and the panel must be no more than the dimension given in Figure 3.

1.5. PC Board Mounting (Headers)

1. Ensure that the pc board material and thickness, layout, and hole configuration meets the requirements given on the connector customer drawing.
2. If applicable, attach the mounting ears onto the header using 3/8-in. long 6-32 pan head screws (customer supplied). Refer to Figure 1.
3. Mount the header to the pc board using the soldering requirements given on [114-1010](#).

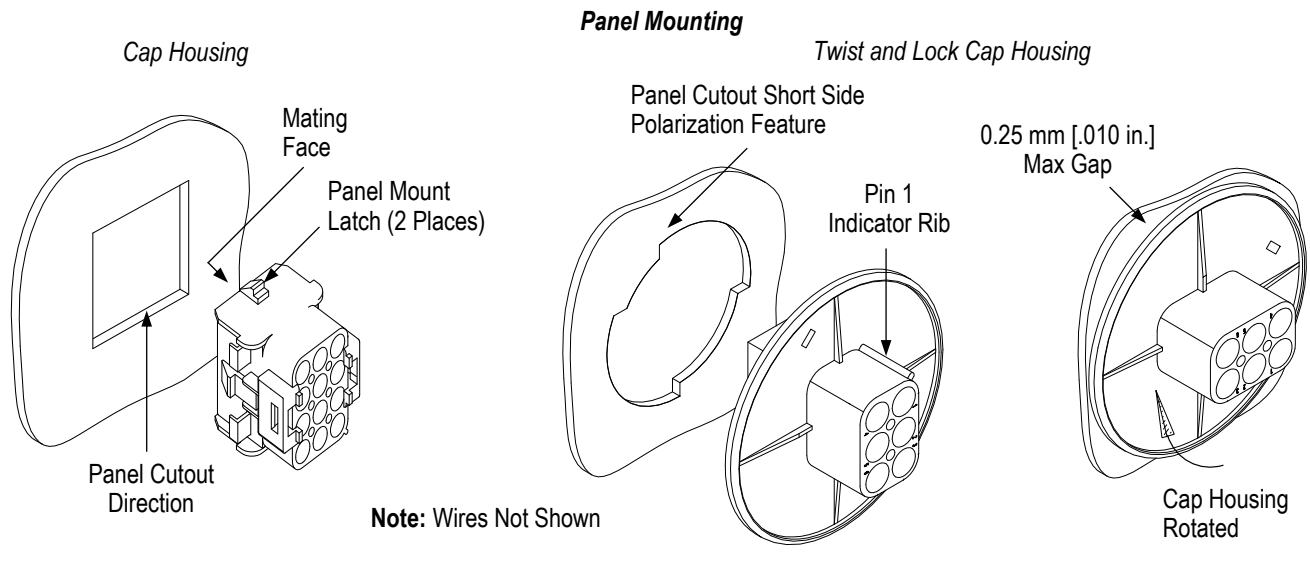

Figure 3

1.6. Mating

Ensure that the mating connectors have identical number of circuits and a pin contact mating with a socket contact. Align the mating faces of the connectors, and push them together until the locking latch fully engages the locking tab. See Figure 4.

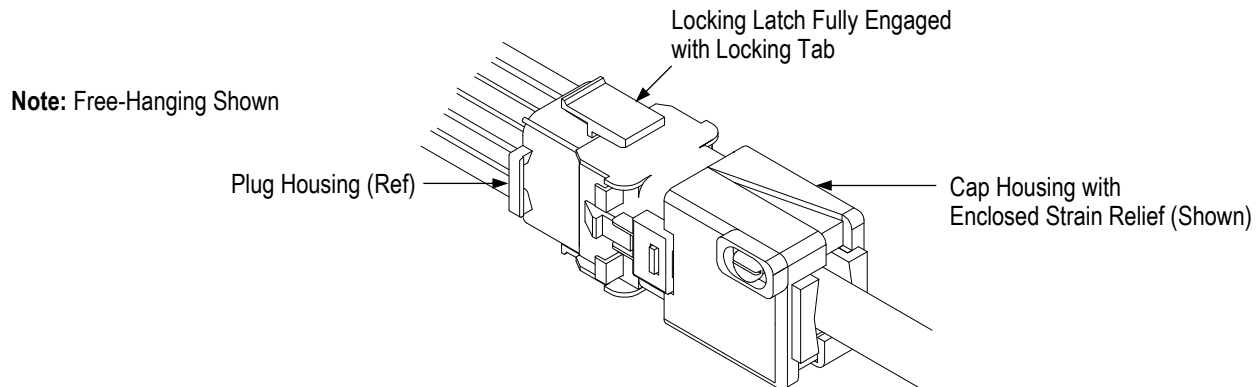

Figure 4

2. CONTACT EXTRACTION

Individual contacts can be removed from the plug or cap housing using extraction tool 318851-1 according to [408-4371](#) packaged with the tool.

3. REPLACEMENT AND REPAIR

Do not use defective or damaged product. These products cannot be repaired. For replacement information, call the number at the bottom of page 1.

4. REVISION SUMMARY

Revisions to this instruction sheet include:

- Updated document to corporate requirements
- Updated assembly procedure in Paragraph 1.1.2