

THIS DRAWING IS UNPUBLISHED. RELEASED FOR PUBLICATION
 © COPYRIGHT - By - ALL RIGHTS RESERVED.

LOC		DIST		REVISIONS			
P	LTR	DESCRIPTION	DATE	DWN	APVD		
CM	OO	S	REVISED PER ECR-12-013323	09AUG12	KH	TM	

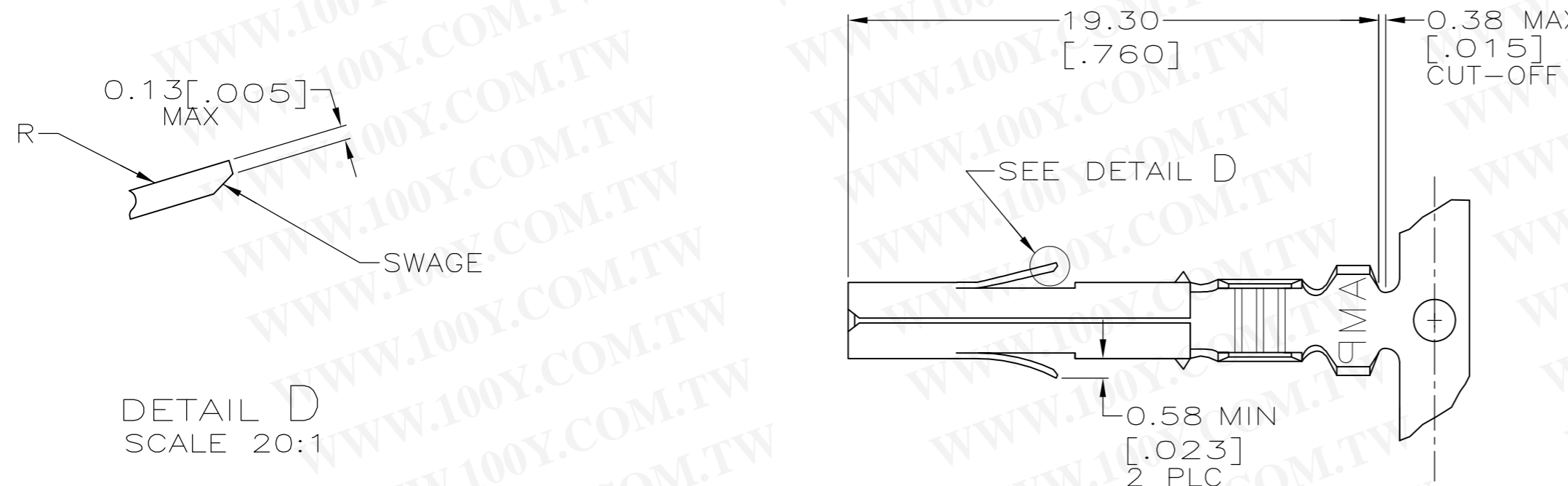

DETAIL D
SCALE 20:1

- 1 0.00076 [.000030] THICK GOLD OVER NICKEL ON INSIDE OF RECEPTACLE; REMAINDER OF CONTACT IS NICKEL PLATED.
- 2 0.00076 [.000030] THICK GOLD OVER NICKEL ON INSIDE OF RECEPTACLE AND WIRE BARREL; REMAINDER OF CONTACT IS NICKEL PLATED.
- 3 NOT MANUFACTURED UN USA.
- 4 DIMENSIONS IN BRACKETS ARE IN INCHES.
- 5 WIRE RANGE: 24-18 AWG
- 6 INSULATION RANGE: 1.02-2.54 [.040-.100] DIA.

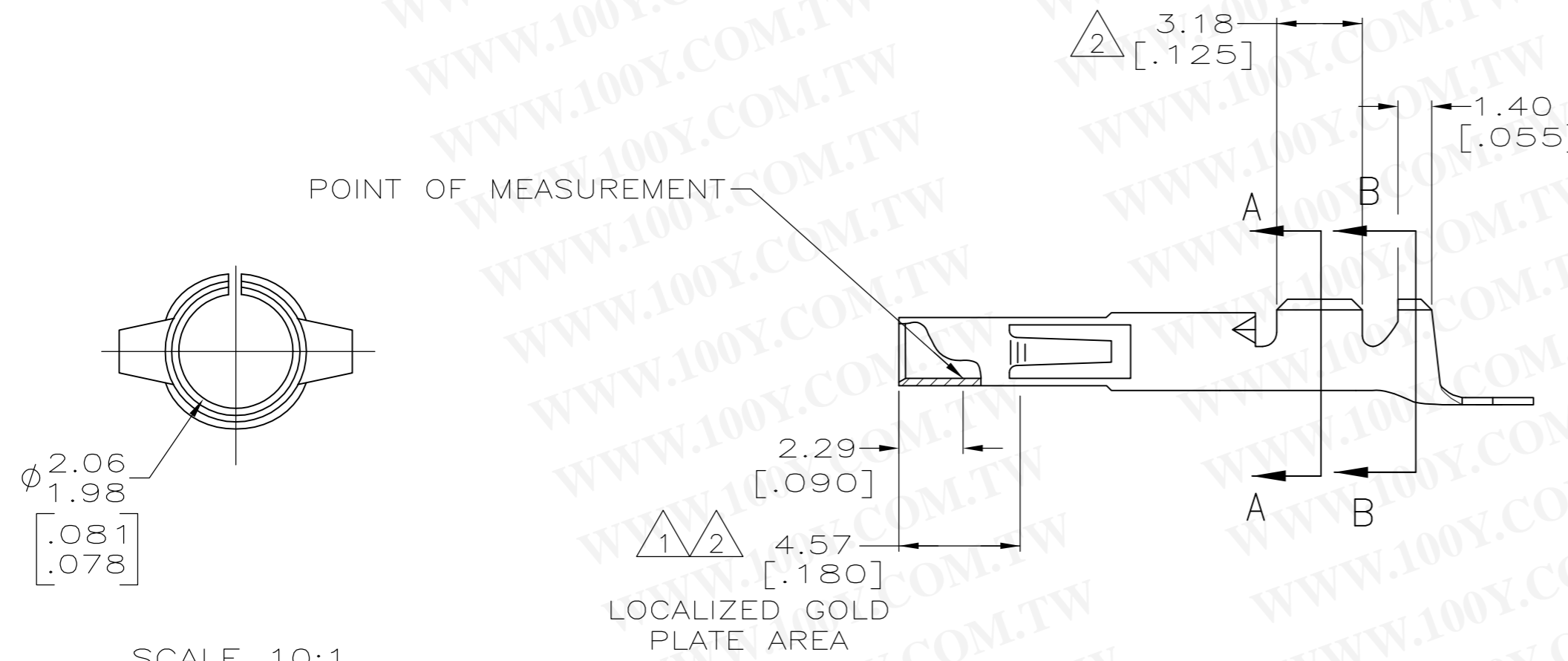

SCALE 10:1

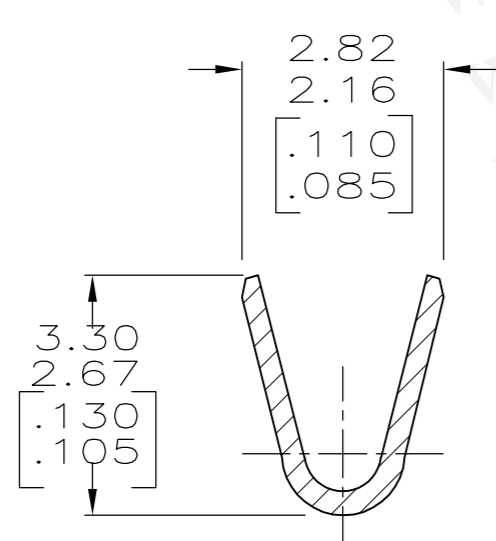

SECTION A-A
SCALE 10:1

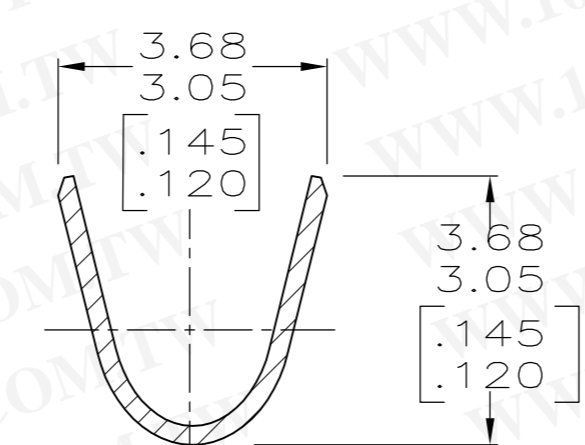

SECTION B-B
SCALE 10:1

勝特力材料 886-3-5753170
 勝特力电子(上海) 86-21-34970699
 勝特力电子(深圳) 86-755-83298787
[Http://www.100y.com.tw](http://www.100y.com.tw)

MATERIAL	FINISH	PART NUMBER
0.25 [.010] BRASS	GOLD 1	350689-7
0.25 [.010] PH BRZ	GOLD 1 3	350689-6
0.25 [.010] PH BRZ	PRE-TIN	350689-3
0.25 [.010] BRASS	GOLD 2	350689-2
0.25 [.010] BRASS	PRE-TIN	350689-1

THIS DRAWING IS A CONTROLLED DOCUMENT.		DWN K. WHITAKER 13-JAN-04		
DIMENSIONS: mm		CHK S. RIDGILL 13-JAN-04		
TOLERANCES UNLESS OTHERWISE SPECIFIED:		APVD S. RIDGILL 13-JAN-04	NAME SOCKET,(LOOSE PIECE) UNIVERSAL MATE-N-LOK™	
0 PLC ± - 1 PLC ± - 2 PLC ± 0.13 [.005] 3 PLC ± - 4 PLC ± - ANGLES ± 0°30'		PRODUCT SPEC	SIZE A2	
MATERIAL		APPLICATION SPEC	CAGE CODE 00779	DRAWING NO C=350689
FINISH		WEIGHT	SCALE 5:1	SHEET 1 of 1
CUSTOMER DRAWING		REV S		