

REVISIONS				
P	LTR	DESCRIPTION	DATE	APVD
Y		REVISED PER ECR-18-019874	19MAR2019	BDA SG

勝特力材料 886-3-5753170
勝特力电子(上海) 86-21-34970699
勝特力电子(深圳) 86-755-83298787
[Http://www.100y.com.tw](http://www.100y.com.tw)

- ① 0.00203 [.000080] MIN MATTE TIN-LEAD OVER
0.00127 [.000050] MIN NICKEL.
- ② 0.00330 [.000130] MAX PRE-TIN.
- ③ 0.00013 [.000005] GOLD OVER 0.00127 [.000050]
MIN NICKEL ALL OVER AND 0.00076 [.000030] MIN
GOLD ON CONTACT AREA.
- 4. WIRE RANGE: 0.2-0.9mm² (24-18 AWG).
INSULATION RANGE: 2.79 [.110] DIA MAX.
- 5. DIMENSIONS IN BRACKETS ARE IN INCHES.
- ⑥ 0.00203 [.000080] MIN MATTE TIN OVER
0.00127 [.000050] MIN NICKEL.
- ⑦ OBSOLETE

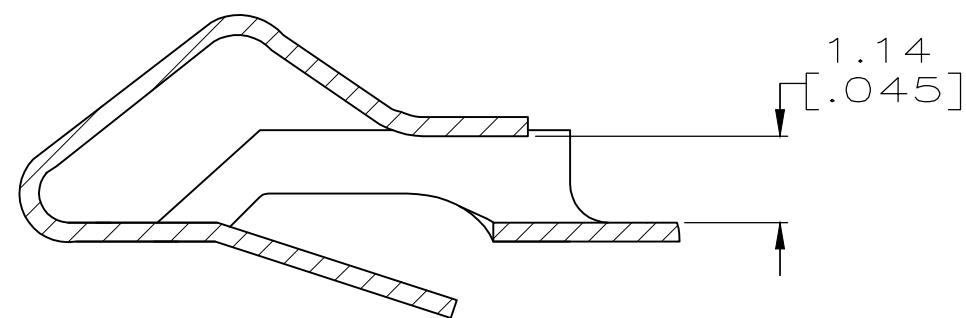
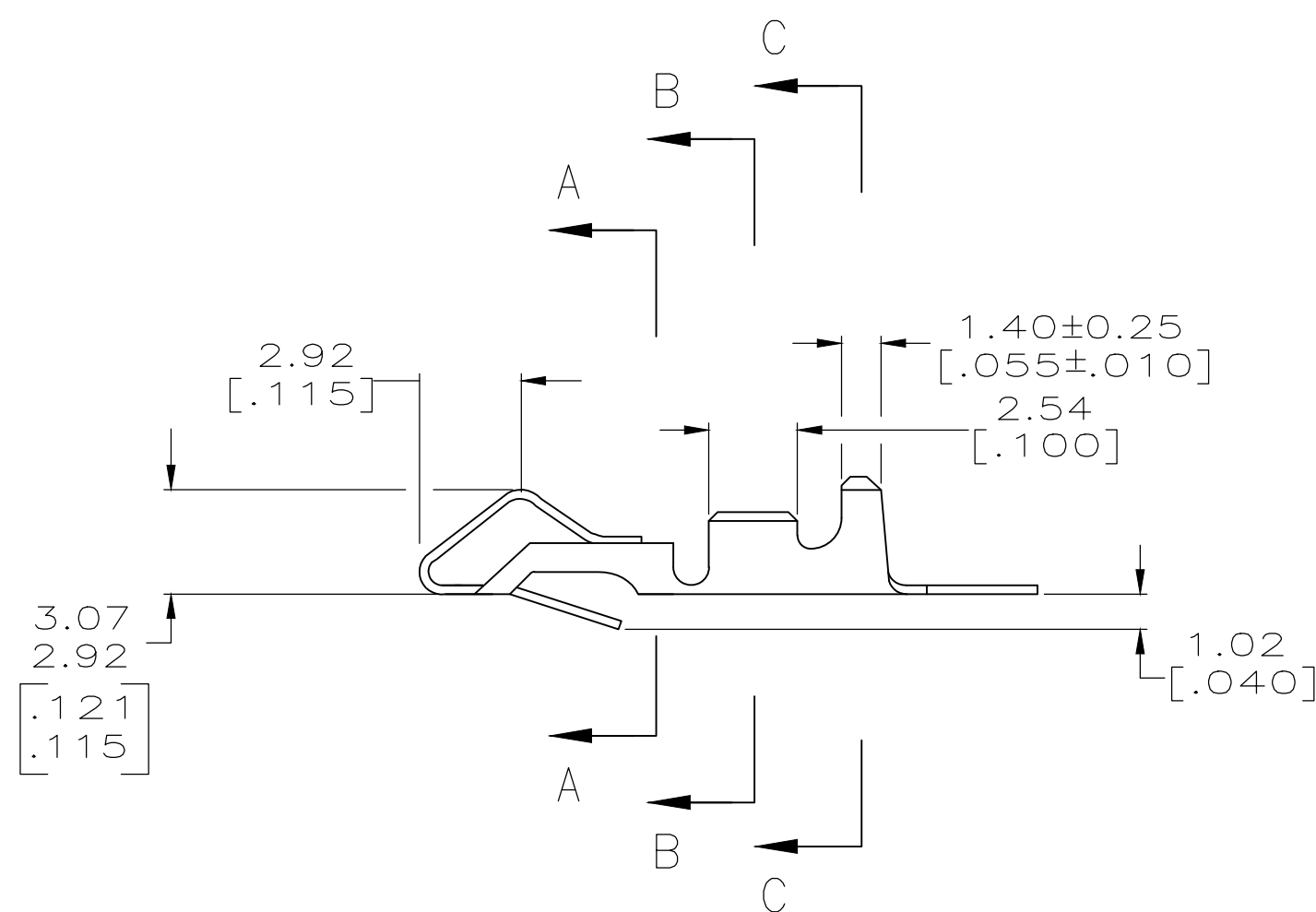
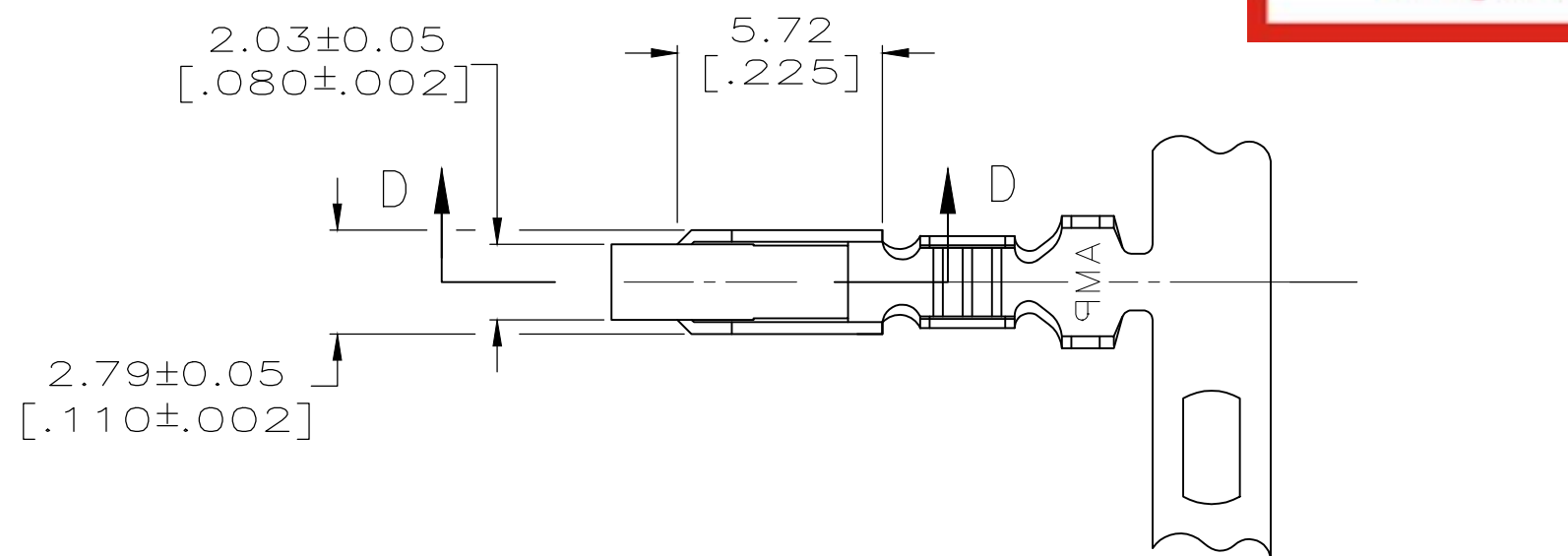

SECTION D-D
SCALE 10:1

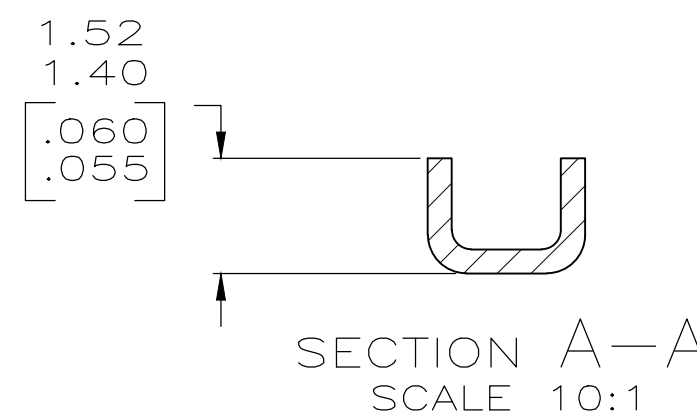

SECTION A-A
SCALE 10:1

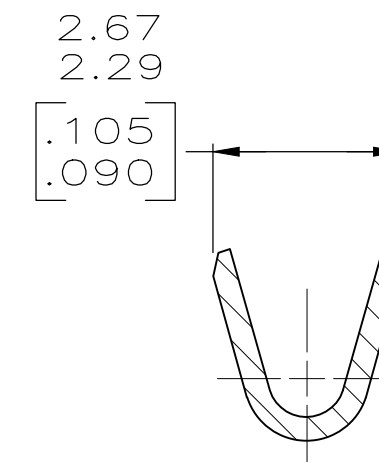

SECTION B-B
SCALE 10:1

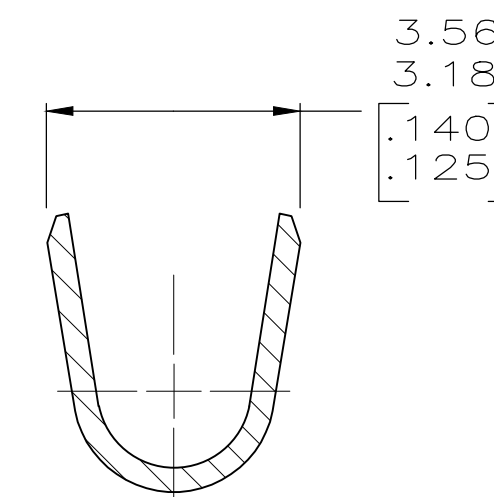

SECTION C-C
SCALE 10:1

MINI	SEE 3-640706-1	⑥	3-640252-1
MINI	SEE 640706-2	②	640252-2
MINI	SEE 640706-1	①	⑦ 640252-1
APPLICATOR	LOOSE PIECE	FINISH	PART NO

THIS DRAWING IS A CONTROLLED DOCUMENT.		DWN S. CARPENTER 21AUG2003	TE Connectivity Ltd.	
DIMENSIONS: INCHES		CHK J. ELLIS 21AUG2003		
TOLERANCES UNLESS OTHERWISE SPECIFIED:		APVD J. ELLIS 21AUG2003	NAME RECEPTACLE, SL-156	
0 PLC ± 1 PLC ± 2 PLC ± 0.13 [.005] 3 PLC ± 4 PLC ± ANGLES ±		PRODUCT SPEC	RESTRICTED TO	
MATERIAL 0.33 [.013] BRASS		FINISH SEE TABLE	SIZE A2	CAGE CODE 00779
		WEIGHT	DRAWING NO C-640252	SCALE 5:1
		CUSTOMER DRAWING	SHEET 1 OF 1	REV Y