

1. PART MAY BE MOLDED TO DESIRED POSITION SIZE OR CUT TO DESIRED POSITION SIZE FROM A LARGER POSITION SIZE PART. WHEN PART IS CUT TO DESIRED POSITION SIZE, A PORTION OF FRONT LOCKING BAR WILL REMAIN ATTACHED.
2. DIMENSIONS IN BRACKETS ARE IN INCHES.
3. TWO POSITION (-2) PARTS WILL BE MOLDED ONLY.

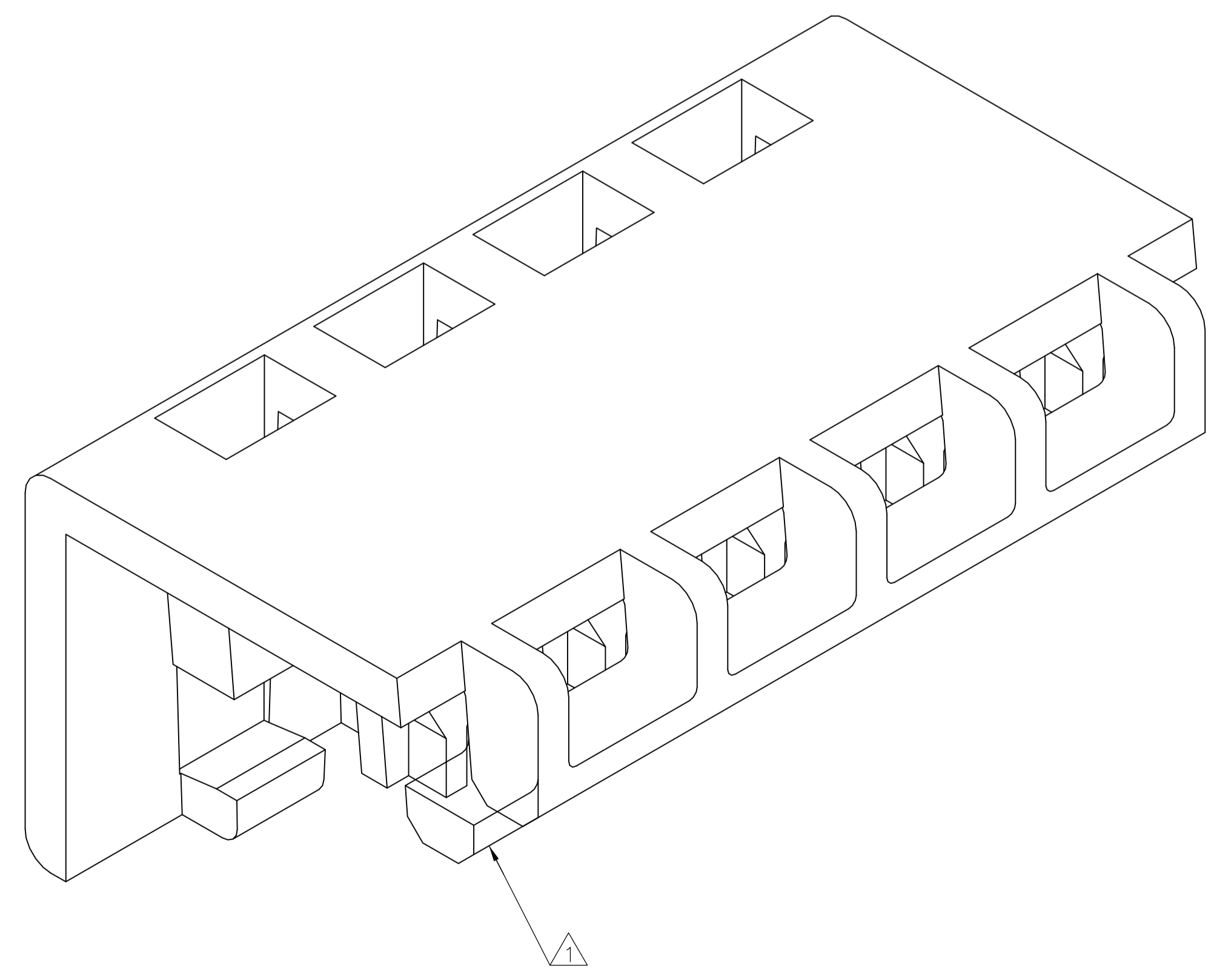

24 CIRCUIT ASSEMBLIES	95.10	[3.744]	2-643067-4
23 CIRCUIT ASSEMBLIES	91.14	[3.588]	2-643067-3
22 CIRCUIT ASSEMBLIES	87.17	[3.432]	2-643067-2
21 CIRCUIT ASSEMBLIES	83.21	[3.276]	2-643067-1
20 CIRCUIT ASSEMBLIES	79.25	[3.120]	2-643067-0
19 CIRCUIT ASSEMBLIES	75.29	[2.964]	1-643067-9
18 CIRCUIT ASSEMBLIES	71.32	[2.808]	1-643067-8
17 CIRCUIT ASSEMBLIES	67.36	[2.652]	1-643067-7
16 CIRCUIT ASSEMBLIES	63.40	[2.496]	1-643067-6
15 CIRCUIT ASSEMBLIES	59.44	[2.340]	1-643067-5
14 CIRCUIT ASSEMBLIES	55.47	[2.184]	1-643067-4
13 CIRCUIT ASSEMBLIES	51.51	[2.028]	1-643067-3
12 CIRCUIT ASSEMBLIES	47.55	[1.872]	1-643067-2
11 CIRCUIT ASSEMBLIES	43.59	[1.716]	1-643067-1
10 CIRCUIT ASSEMBLIES	39.62	[1.560]	1-643067-0
9 CIRCUIT ASSEMBLIES	35.66	[1.404]	643067-9
8 CIRCUIT ASSEMBLIES	31.70	[1.248]	643067-8
7 CIRCUIT ASSEMBLIES	27.74	[1.092]	643067-7
6 CIRCUIT ASSEMBLIES	23.77	[.936]	643067-6
5 CIRCUIT ASSEMBLIES	19.81	[.780]	643067-5
4 CIRCUIT ASSEMBLIES	15.85	[.624]	643067-4
3 CIRCUIT ASSEMBLIES	11.89	[.468]	643067-3
2 CIRCUIT ASSEMBLIES	7.92	[.312]	643067-2
USE ON MTA 156 ASSEMBLIES AS LISTED		A	PART NO

勝特力電材超市-龍山店 886-3-5773766
 勝特力電材超市-光復店 886-3-5729570
 勝特力电子(上海) 86-21-34970699
 勝特力电子(深圳) 86-755-83298787
<http://www.100y.com.tw>

THIS DRAWING IS A CONTROLLED DOCUMENT.		DIN	5-21-91	TE Connectivity
		CHK	5-21-91	
DIMENSIONS: INCHES		TOLERANCES UNLESS OTHERWISE SPECIFIED:		NAME COVER, MOLDED, .095 MAX O.D. WIRE, MTA-156
0 PLC ± - 1 PLC ± - 2 PLC ± - 3 PLC ± 0.13 [.005] 4 PLC ± - ANGLES ± -		R SWING G MILLER 5-22-91 PRODUCT SPEC		
MATERIAL: NYLON,UL 94V-2 WHITE		FINISH: -		APPLICATION SPEC SIZE: A1 CAGE CODE: 00779 DRAWING NO: 643067 WEIGHT: - CUSTOMER DRAWING
4805 (3/11)		SCALE: 10:1		RESTRICTED TO: SHEET 1 OF 1 REV G1

REV	REASON	MTA 156 RIBBON CABLE CONNECTOR ASSEMBLIES	ENGINEERING RELEASE DATE
C	Per ECN AG-704		1-20-89
D	Per Eng. Mark-up (Figures 3 & 7)		APPROVAL
			WILLIAM GENTRY

1. INTRODUCTION

This specification covers the requirements for application of .156 centerline ribbon cable to AMP* MTA 156 wire-to-post, card edge and wire-to-wire connectors. Specific cable approved for use with these connectors is 18-26 AWG tin plated solid, 7 strand concentric fused, 7 and 19 strand concentric stranded cable per UL 2651 or 2884, standard PVC thermoplastic insulated class 12 with a 105°C rating with a maximum insulation outside diameter of .094 when terminating one position at a time, or .070 when mass terminating.

NOTE

All dimensions on this document are in inches unless otherwise specified. All dimensional tolerances are $\pm .005$ and angular tolerances are $\pm 1^\circ$ unless otherwise specified. Metric equivalents (mm) can be calculated by multiplying the given dimension by 25.4.

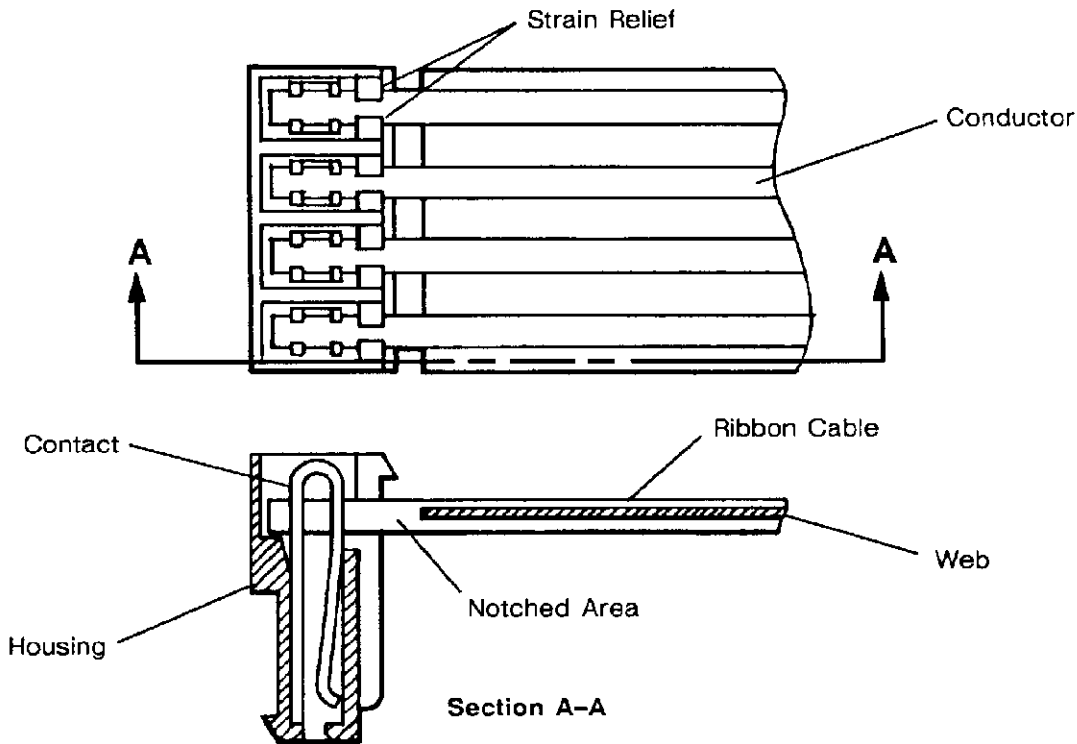

Fig. 1. Product Features

2. REFERENCE MATERIAL

2.1. Product Part Numbers and Product Code

Product Part Number 772040 and Product Code 0526 are representative of the AMP MTA 156 Ribbon Cable Connector Assembly series. Use of these numbers will identify the product line and expedite your inquiries through an AMP service network established to help you obtain product and tooling information. Such information can be obtained through a local AMP Representative (Field Sales Engineer, Field Applications Engineer, etc.) or, after purchase, by calling the CUSTOMER HOTLINE at the top of the first page.

2.2. Customer Drawing

An AMP Customer Drawing is available for each part number assigned to this product line. In the event of a conflict between this specification and the customer drawing, the customer drawing information will take precedence.

2.3. Product Specifications

AMP Product Specifications 108-1051 (wire-to-post), 108-1058 (card edge), and 108-1065 (wire-to-wire) provide performance requirements and test data relating to connectors.

2.4. Instructional Material

Instruction Sheet IS 6521 covers cable preparation and notching procedure, and Instruction Sheets IS 7995, IS 6701, and IS 6923 cover tooling for terminating connectors to ribbon cable.

3. REQUIREMENTS

3.1. Connector Selection

Determine the wire size specified for your application, then select a connector of the color that matches the wire size. See Figure 2.

WIRE SIZE (AWG)	CONNECTOR COLOR
18	Orange
20	Yellow
22	Red
24	Natural
26	Blue

Fig. 2. Connector Selection

3.2. Cable Ends

Ends of the cable shall be prepared as indicated in Figure 3.

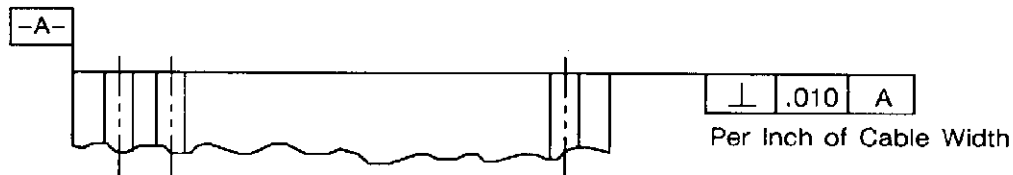
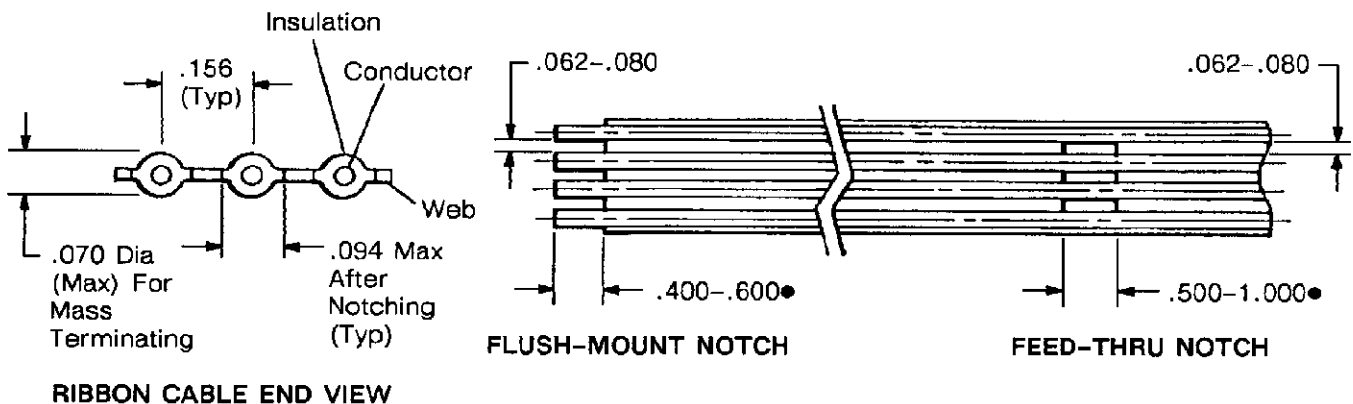

Fig. 3. Cable Edge-to-End Alignment

3.3. Cable Preparation

Cable shall be notched, as indicated in the individual ribbon cable connector assembly drawing, according to the requirements specified in Figure 4. Conductor shall not be exposed after notching, nor shall individual wire strands be cut or nicked.



• The dimensions shown represent the recommended minimum and maximum for notches; the actual dimension will depend on your application requirements.

Fig. 4. Cable Dimensions

3.4. Cable Termination

After termination, cable shall meet the requirements specified in Figure 5, and assembly shall meet the requirements of Figure 6.

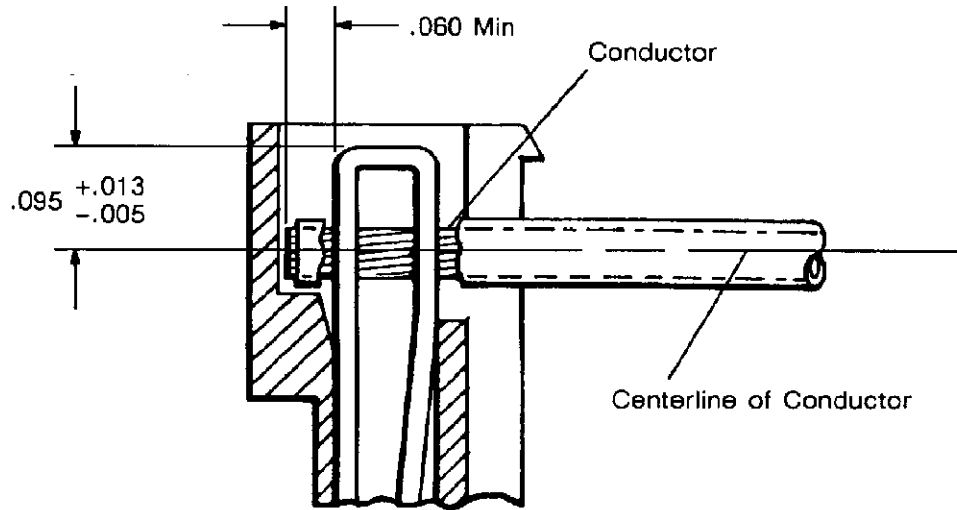

Fig. 5. Conductor Placement in Contact

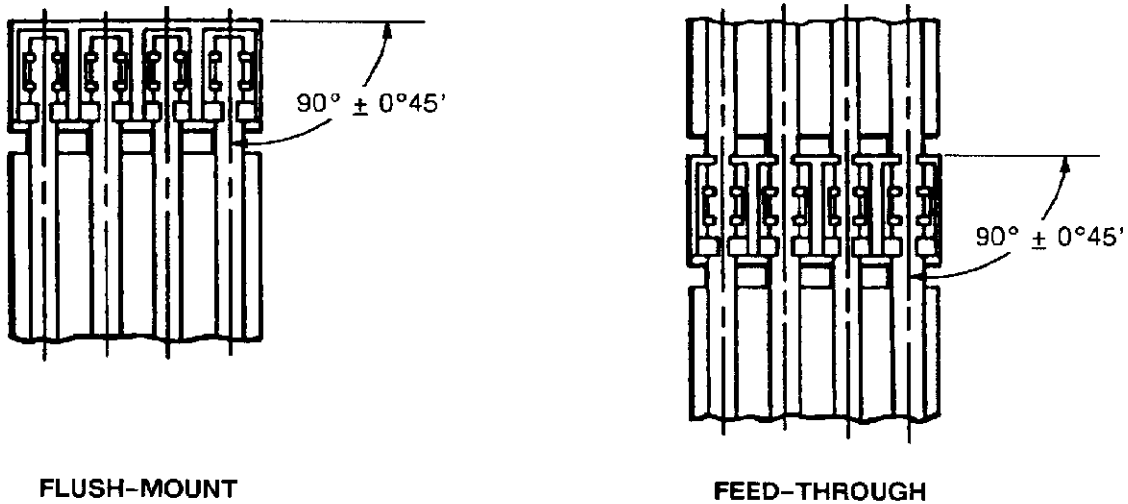

Fig. 6. Connector and Cable Alignment

3.5. Contact Damage

There shall be no evidence of physical damage or distortion to any portion of the contact after cable termination.

3.6. Housing Damage

A. Visible Damage

There shall be no cracks, breaks, or other visible damage to the housing due to cable termination.

B. Skiving

Skiving of plastic on the inside wall of the housing cavity is permissible provided that conditions specified in Paragraph 3.6.A. are met.

3.7. Broken Strands

There shall be no broken strands in the conductor after termination.

3.8. Exposed Conductor

Exposed conductors shall not exceed the limits specified in Figure 7 after termination.

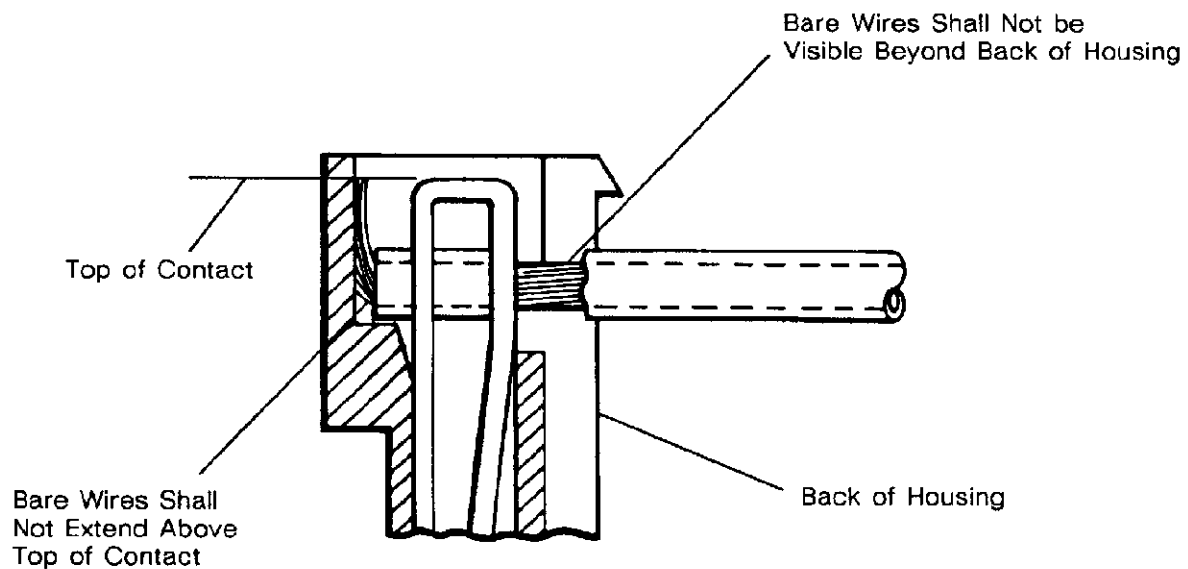

Fig. 7. Exposed Conductor Limitation

3.9. Conductor Insulation

Conductor insulation shall be contained within the confines of the insulation strain relief as indicated in Figure 8.

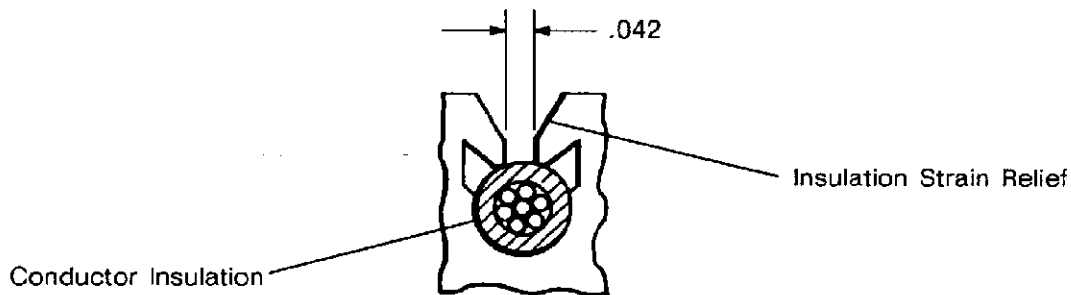

Fig. 8. Strain Relief

4. QUALIFYING SUPPORT

AMP MTA 156 Ribbon Cable Connector Assemblies are UL recognized and CSA certified.

5. TOOLING

5.1. Notching Cable

For ribbon cable notching, use AMP Ribbon Cable Notching Tool 59835-1. For instructions, refer to Instruction Sheet IS 6521.

5.2. Terminating Cable

For attaching connectors to ribbon cable, use the AMP Arbor Frame Assembly, Upper Tooling, and Holding Fixture that matches the connector type that you are terminating. See Figure 9.

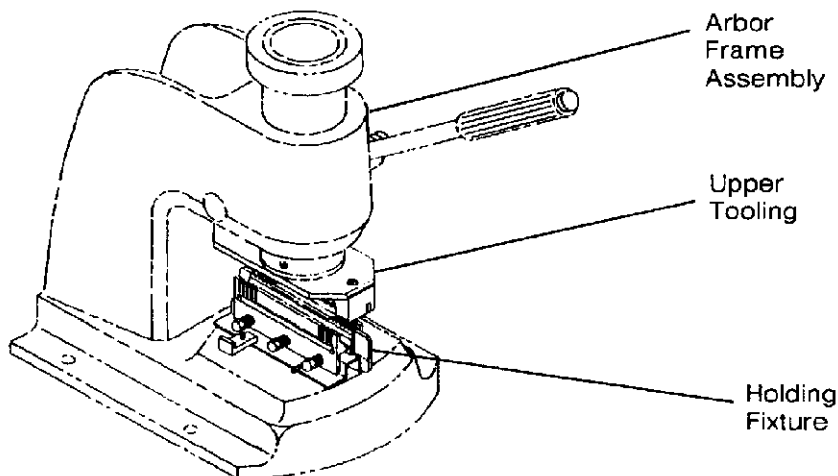

CONNECTOR STYLE	HOLDING FIXTURES (IS 7995)		UPPER TOOLING (IS 6701)	ARBOR FRAME ASSY (IS 6923)
	FLUSH-MOUNT	FEED-THROUGH		
Card Edge●	58006-1	---	58040-1 ↓	58024-1 ↓
Card Edge	59848-1	---		
Posted	58009-1	58010-1		
Receptacle	58244-1	58245-1		

● For card edge connectors of 16 positions or greater with mounting ears.

Fig. 9. Tool Selection

6. VISUAL AID

Figure 10 shows a properly terminated AMP MTA Ribbon Cable Connector Assembly. The illustrations depict, in general, the conditions that production personnel should check to ensure a correct installation.

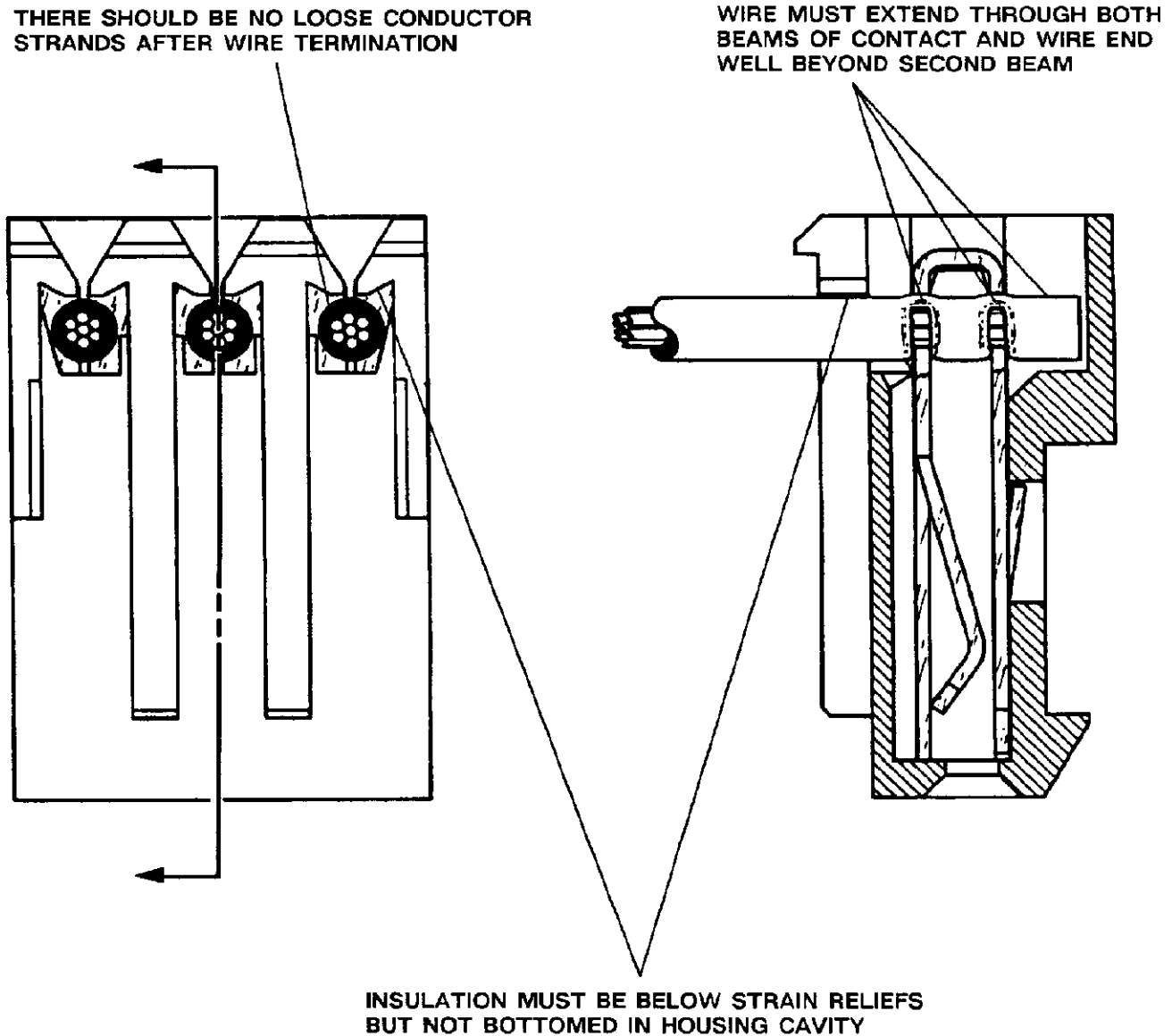

FIG. 10. VISUAL AID