

Project No. PRJ-11-00001417	Loc A1	DIST -	REVISIONS			
			REV	DATE	BY	APPV
			C4	06FEB2014	Abr	Raab
			C5	12JUN2014	Abr	Raab
			C6	25AUG2014	Abr	Raab
			C7	21DEC2017	FRAN	KURF

REVISION Aenderungsstand /
NUMBER CODE PRODUCTION TOOL
Nummercode Produktionswerkzeug

MANUFACTURING LOCATION CODE
Kennzahl Produktionsstandort

STANDARD APPLICATION
Standard Anwendung

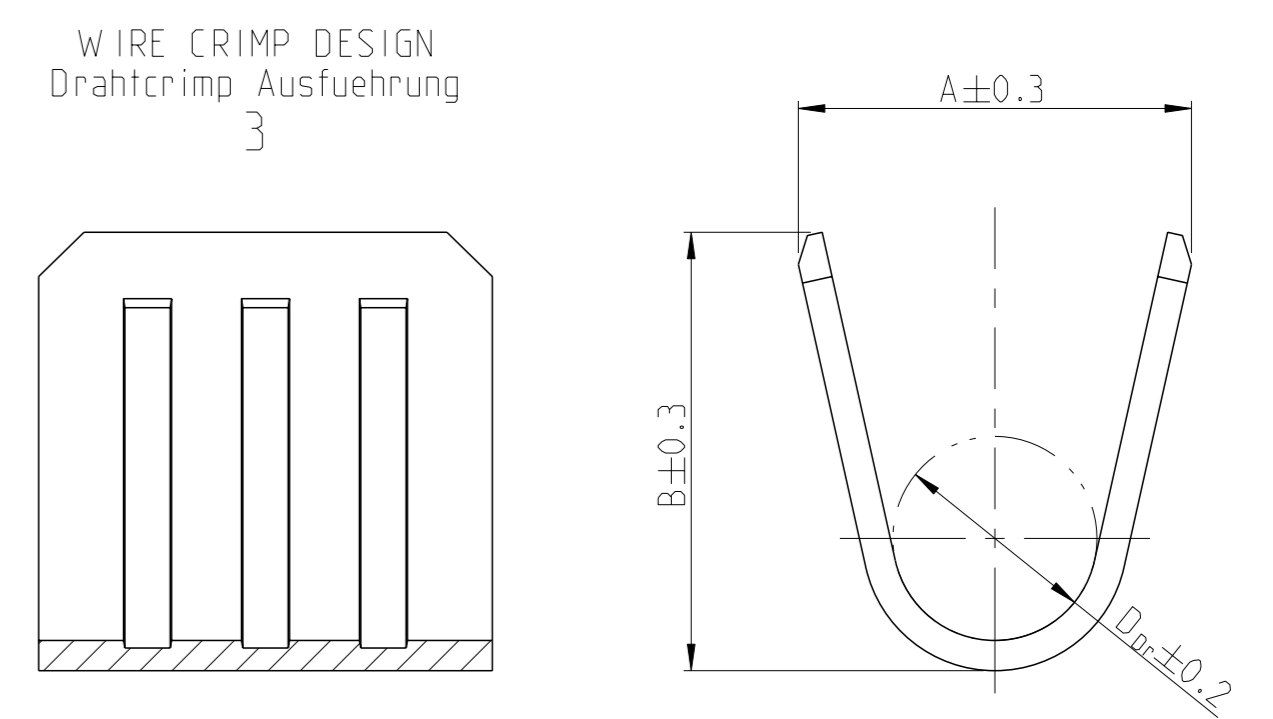
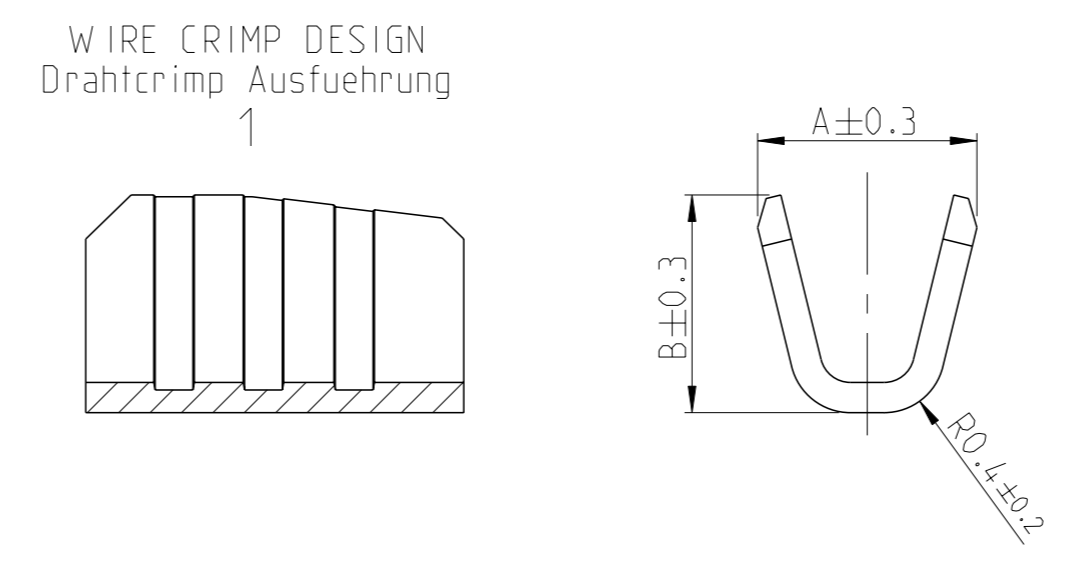
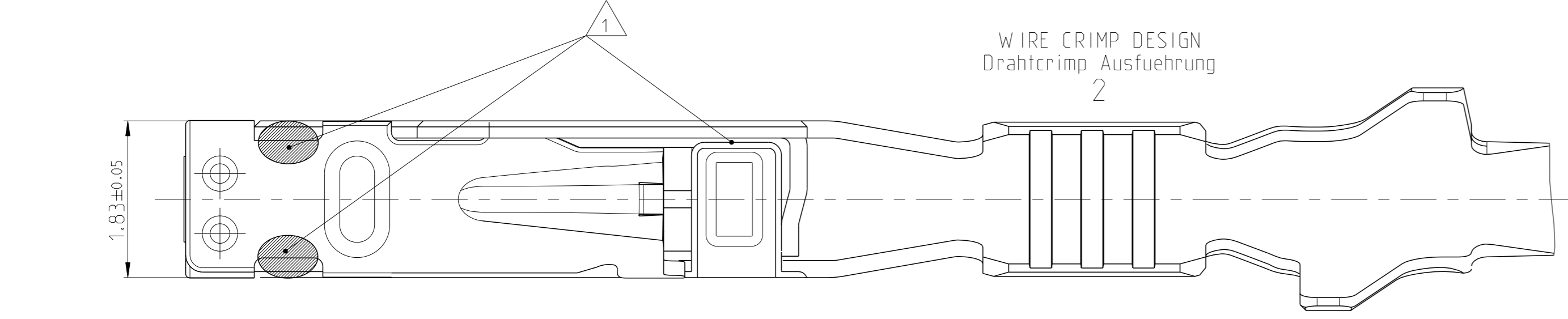
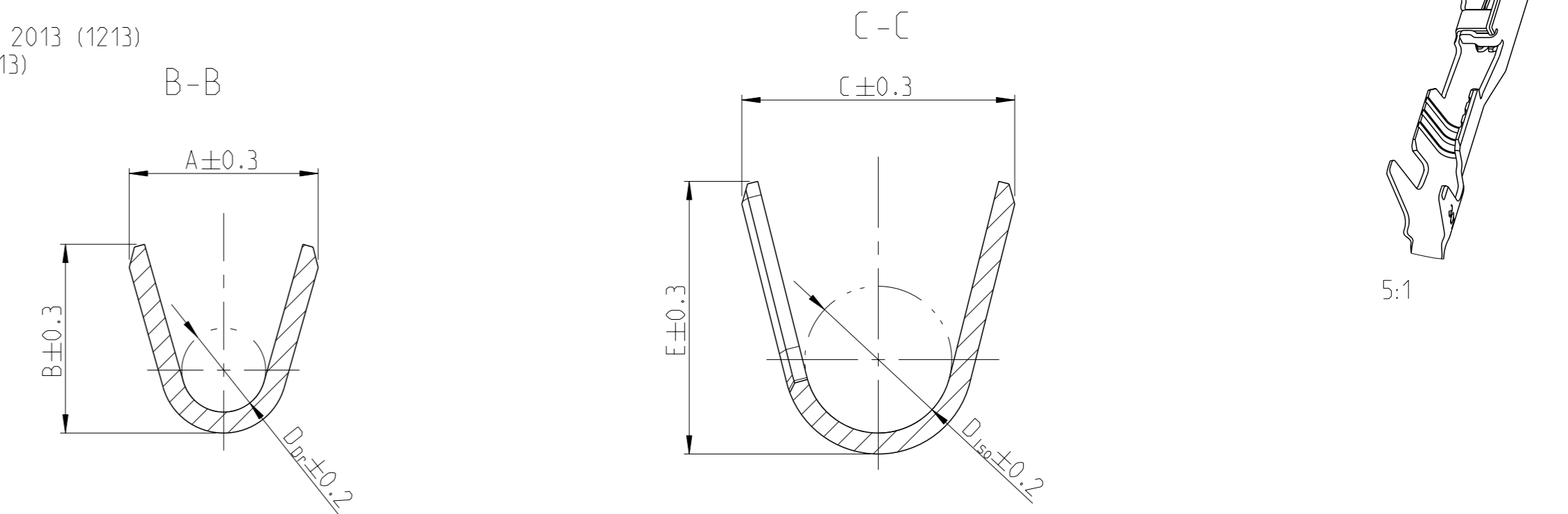
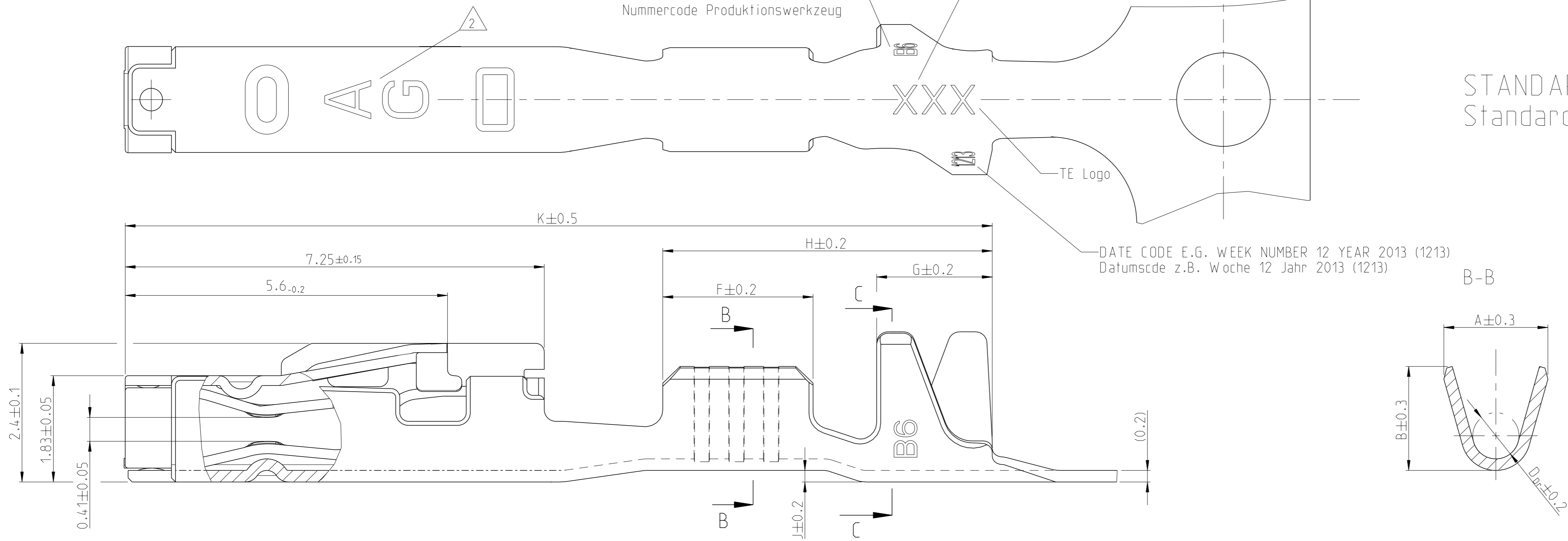

SINGLE WIRE SEALING SYSTEM
Einzelleiterdichtungssystem

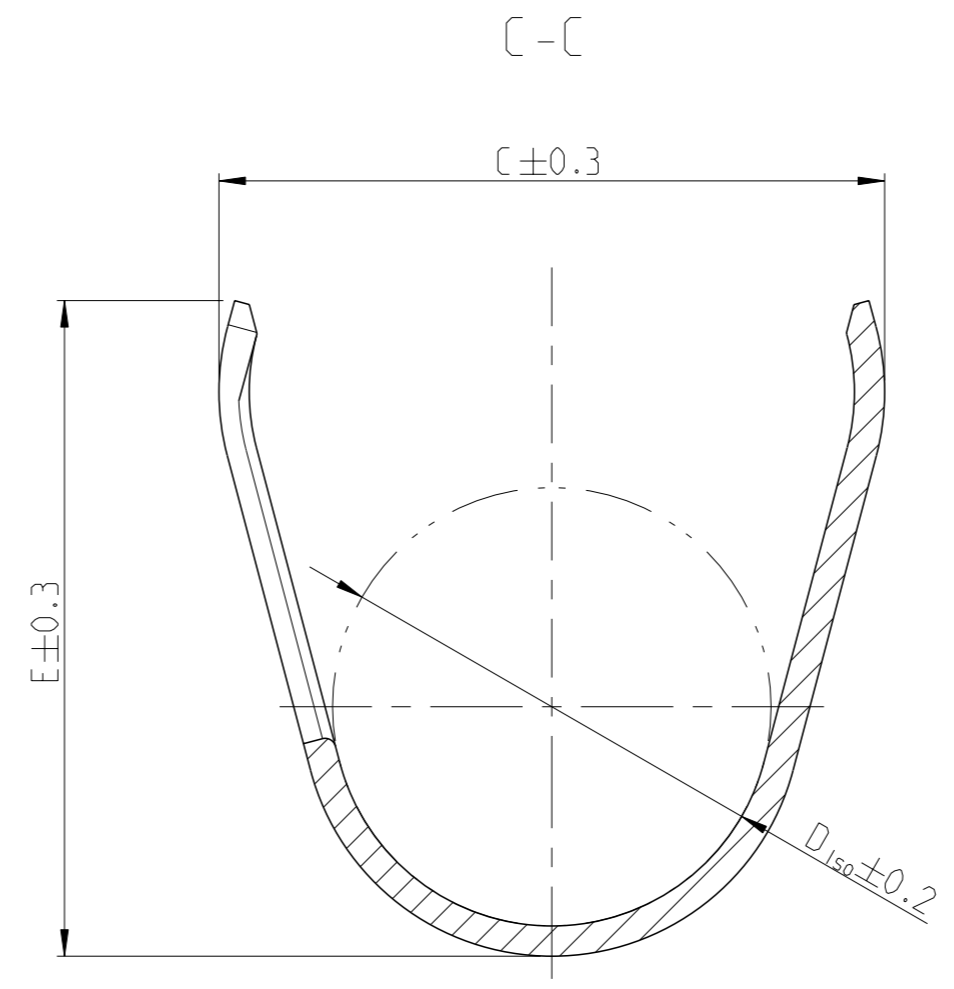
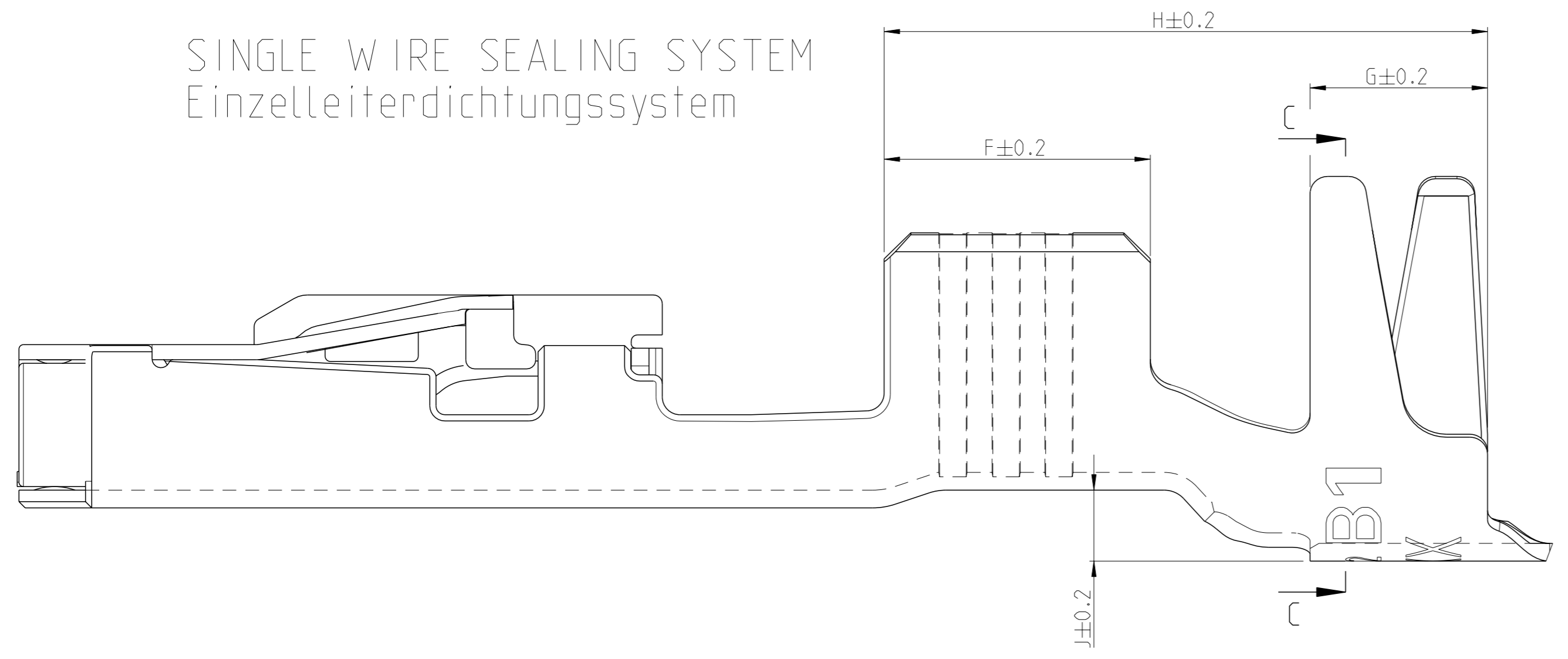

- NOTES
Bemerkungen
- 1 LASER WELDED
Lasergeschweisst
 - 2 STAMPED INDICATOR FOR PLATING:
- AU GOLD PLATING
- AG SILVER PLATING
- TIN PLATING WITHOUT INDICATOR
Markierung fuer galvanische Ausfuehrung:
- AU vergoldet
- AG versilbert
- verzinkt: ohne Markierung
 - 3 TO BE USED ON TAB
1.2±0.1 x 0.6±0.03 MM
geeignet fuer Flachstecker
1.2±0.1 x 0.6±0.03 mm

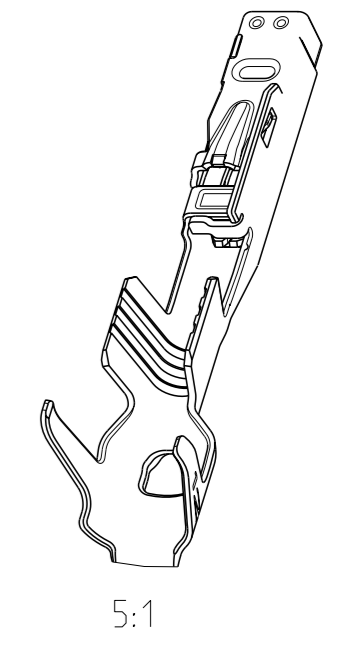

勝特力電材超市-龍山店 886-3-5773766
勝特力電材超市-光復店 886-3-5729570
勝特力电子(上海) 86-21-34970699
勝特力电子(深圳) 86-755-83298787
<http://www.100y.com.tw>

THIS DRAWING IS A CONTROLLED DOCUMENT.		OWN E. Horn	11NOV2011	TE Connectivity NAME MCON 1.2 LL (LOCKING-LANCE)
DIMENSIONS: mm		CHK R. Meier	11NOV2011	
TOLERANCES UNLESS OTHERWISE SPECIFIED: ±0.2		APPV V. Seigel	11NOV2011	SIZE 108-18782
MATERIAL		FINISH		APPLICATION SPEC 114-18464
WEIGHT 0.18 g		Customer Drawing		RESTRICTED TO -
SCALE 20:1		SHEET 1 of 2		REV 7

LOC	DIST	REVISIONS			
A1	-	REV	DATE	OWN	APVD
		1	SEE SHEET 1	-	-

VERSION / Ausführung	REV.	RANGE Bereich	INSULATION-Ø Isolations-Ø (mm)	AWG	mm ²	BODY Kontakt-körper	SPRING Kontakt-feder	BODY Kontakt-körper	SPRING Kontakt-feder	DESIGN WIRE-CRIMP Ausführung Draht-Crimp	SINGLE WIRE SEAL FOR CAVITY DIAMETER											BLINDPLUG ORDER NO. Blindstopfen Bestell-Nr.	APPLICATION TOOLS Verarbeitungswerkzeuge	
											A	B	D _{Dr}	C	E	D _{ISO}	F	G	H	J	K			
STANDARD APPLICATION Standardanwendung	2141970-3	A	0.13-	0.95-	-	0.13	CuSn4	CuNiSi	8	7	1	1.5	1.4	-	4.0	3.9	2.6	2.5	1.9	6.2	0.6	16	SEE APPLICATION SPEC. 114-18464 siehe Verarbeitungsspez. 114-18464	
	2141970-2	A	0.22	0.95-	-	0.17				6	1	1.5	1.4	-	4.0	3.9	2.6	2.5	1.9	6.2	0.6	16		
	2141970-1	A	9	1.2	-	0.22				5	1	1.5	1.4	-	4.0	3.9	2.6	2.5	1.9	6.2	0.6	16		
	7-1452665-3	A	0.25-	1.1-	-	0.25				7	2	1.8	1.8	0.8	4.2	4.3	2.6	2.6	2.0	6.4	0.8	16		
	7-1452665-2	A	0.25-	1.1-	24	-				6	2	1.8	1.8	0.8	4.2	4.3	2.6	2.6	2.0	6.4	0.8	16		
	7-1452665-1	A	0.35	1.75	22	-				5	2	1.8	1.8	0.8	4.2	4.3	2.6	2.6	2.0	6.4	0.8	16		
	7-1452668-3	A	0.5-	1.4-	20	0.5				7	2	2.0	2.1	1.1	4.2	4.3	2.7	2.6	2.0	6.4	0.8	16		
	7-1452668-2	A	0.5-	1.4-	-	0.75				6	2	2.0	2.1	1.1	4.2	4.3	2.7	2.6	2.0	6.4	0.8	16		
	7-1452668-1	A	0.75	1.9	-	0.75				5	2	2.0	2.1	1.1	4.2	4.3	2.7	2.6	2.0	6.4	0.8	16		
	7-1452671-3	A	1-	1.9-	18	-				7	2	2.6	2.9	1.35	4.4	4.3	2.9	3.0	2.0	6.8	0.8	16.55		
	7-1452671-2	A	1-	1.9-	-	1				6	2	2.6	2.9	1.35	4.4	4.3	2.9	3.0	2.0	6.8	0.8	16.55		
	7-1452671-1	A	1.5	2.4	16	-				5	2	2.6	2.9	1.35	4.4	4.3	2.9	3.0	2.0	6.8	0.8	16.55		
7-1452671-1	A	1.5	2.4	-	1.5	5	2	2.6	2.9	1.35	4.4	4.3	2.9	3.0	2.0	6.8	0.8	16.55						
2141861-3	A	0.13-	0.95-	-	0.13	CuSn4	CuNiSi	8	7	1	1.5	1.4	-	2.0	1.9	1.1	2.5	1.7	5.4	0	15	SEE APPLICATION SPEC. 114-18464 siehe Verarbeitungsspez. 114-18464		
2141861-2	A	0.22	0.95-	-	0.17				6	1	1.5	1.4	-	2.0	1.9	1.1	2.5	1.7	5.4	0	15			
2141861-1	A	9	1.2	-	0.22				5	1	1.5	1.4	-	2.0	1.9	1.1	2.5	1.7	5.4	0	15			
7-1452653-3	A	0.25-	1.1-	-	0.25				7	2	1.8	1.8	0.8	2.6	2.6	1.4	2.6	2.0	5.7	0.2	15			
7-1452653-2	A	0.25-	1.1-	24	-				6	2	1.8	1.8	0.8	2.6	2.6	1.4	2.6	2.0	5.7	0.2	15			
7-1452653-1	A	0.35	1.75	22	-				5	2	1.8	1.8	0.8	2.6	2.6	1.4	2.6	2.0	5.7	0.2	15			
7-1452656-3	A	0.5-	1.4-	20	0.5				7	2	2.0	2.1	1.1	2.7	2.9	1.6	3.0	2.0	6.1	0.2	16			
7-1452656-2	A	0.5-	1.4-	-	0.75				6	2	2.0	2.1	1.1	2.7	2.9	1.6	3.0	2.0	6.1	0.2	16			
7-1452656-1	A	0.75	1.9	-	0.75				5	2	2.0	2.1	1.1	2.7	2.9	1.6	3.0	2.0	6.1	0.2	16			
7-1452659-3	A	1-	1.9-	18	-				7	2	2.6	2.9	1.35	3.7	3.9	2.1	3.0	2.0	6.1	0.2	16			
7-1452659-2	A	1-	1.9-	-	1				6	2	2.6	2.9	1.35	3.7	3.9	2.1	3.0	2.0	6.1	0.2	16			
7-1452659-1	A	1.5	2.4	16	-				5	2	2.6	2.9	1.35	3.7	3.9	2.1	3.0	2.0	6.1	0.2	16			
7-1452659-1	A	1.5	2.4	-	1.5	5	2	2.6	2.9	1.35	3.7	3.9	2.1	3.0	2.0	6.1	0.2	16						

7- VARIANTS FOR NEW APPLICATIONS

- NOTES
Bemerkungen
- 4 ONLY FOR FLR-WIRE SEE DIN 72551, PART 6 AND AWG WIRE ACCORDING DC-SPEC: MS-8288 ; MS-7889 ; MS-9532
Nur fuer FLR-Leitung nach DIN 72551, Teil 6 und AWG Leitung nach DC-SPEC: MS-8288 ; MS-7889 ; MS-9532
 - 5 PRE TIN SnAg 1.0 TO 3.0µm
Vorverzinkt SnAg 1.0 bis 3.0µm
 - 6 SPRING GOLD PLATED MIN. 0.8µm (only contact area)
Kontaktfeder galv. vergoldeft min.0.8µm (nur Kontaktzone)
 - 7 SPRING SILVER PLATED 2.0 TO 5.0µm (only contact area)
Kontaktfeder galv. versilbert 2.0 bis 5.0µm (nur Kontaktzone)
 - 8 BODY PRE TIN Sn 1.0 TO 3.0µm
Kontaktkoerper vorverzinkt Sn 1.0 bis 3.0µm
 - 9 REINFORCED WIRE ACCORDING TO LV 112-4
Zugverstaerkte Leitung nach LV 112-4

VERSION / Ausführung	REV.	RANGE Bereich	INSULATION-Ø Isolations-Ø (mm)	AWG	mm ²	BODY Kontakt-körper	SPRING Kontakt-feder	BODY Kontakt-körper	SPRING Kontakt-feder	DESIGN WIRE-CRIMP Ausführung Draht-Crimp	SINGLE WIRE SEAL FOR CAVITY DIAMETER											BLINDPLUG ORDER NO. Blindstopfen Bestell-Nr.	APPLICATION TOOLS Verarbeitungswerkzeuge	
											A	B	D _{Dr}	C	E	D _{ISO}	F	G	H	J	K			
STANDARD APPLICATION Standardanwendung	0-1452665-3	B	0.25-	1.1-	-	0.25	CuSn0.15/0.2	CuNiSi	5	7	2	1.8	1.8	0.8	4.2	4.3	2.6	2.6	2.0	6.4	0.8	16	SEE APPLICATION SPEC. 114-18464 siehe Verarbeitungsspez. 114-18464	
	0-1452665-2	B	0.25-	1.1-	24	-				6	2	1.8	1.8	0.8	4.2	4.3	2.6	2.6	2.0	6.4	0.8	16		
	0-1452665-1	B	0.35	1.75	22	-				5	2	1.8	1.8	0.8	4.2	4.3	2.6	2.6	2.0	6.4	0.8	16		
	0-1452668-3	C	0.5-	1.4-	20	0.5				7	2	2.0	2.1	1.1	4.2	4.3	2.7	2.6	2.0	6.4	0.8	16		
	0-1452668-2	C	0.5-	1.4-	-	0.75				6	2	2.0	2.1	1.1	4.2	4.3	2.7	2.6	2.0	6.4	0.8	16		
	0-1452668-1	C	0.75	1.9	-	0.75				5	2	2.0	2.1	1.1	4.2	4.3	2.7	2.6	2.0	6.4	0.8	16		
	0-1452671-3	B	1-	1.9-	18	-				7	3	2.6	2.9	1.35	4.4	4.3	2.9	3.0	2.0	6.8	0.8	16.55		
	0-1452671-2	B	1-	1.9-	-	1				6	3	2.6	2.9	1.35	4.4	4.3	2.9	3.0	2.0	6.8	0.8	16.55		
	0-1452671-1	B	1.5	2.4	16	-				5	3	2.6	2.9	1.35	4.4	4.3	2.9	3.0	2.0	6.8	0.8	16.55		
	0-1452671-1	B	1.5	2.4	-	1.5				5	3	2.6	2.9	1.35	4.4	4.3	2.9	3.0	2.0	6.8	0.8	16.55		
	0-1452653-3	B	0.25-	1.1-	-	0.25				7	2	1.8	1.8	0.8	2.6	2.6	1.4	2.6	2.0	5.7	0.2	15		
	0-1452653-2	B	0.25-	1.1-	24	-				6	2	1.8	1.8	0.8	2.6	2.6	1.4	2.6	2.0	5.7	0.2	15		
0-1452653-1	B	0.35	1.75	22	-	5	2	1.8	1.8	0.8	2.6	2.6	1.4	2.6	2.0	5.7	0.2	15						
0-1452656-3	C	0.5-	1.4-	20	0.5	7	2	2.0	2.1	1.1	2.7	2.9	1.6	3.0	2.0	6.1	0.2	16						
0-1452656-2	C	0.5-	1.4-	-	0.75	6	2	2.0	2.1	1.1	2.7	2.9	1.6	3.0	2.0	6.1	0.2	16						
0-1452656-1	C	0.75	1.9	-	0.75	5	2	2.0	2.1	1.1	2.7	2.9	1.6	3.0	2.0	6.1	0.2	16						
0-1452659-3	B	1-	1.9-	18	-	7	3	2.6	2.9	1.35	3.7	3.9	2.1	3.0	2.0	6.1	0.2	16						
0-1452659-2	B	1-	1.9-	-	1	6	3	2.6	2.9	1.35	3.7	3.9	2.1	3.0	2.0	6.1	0.2	16						
0-1452659-1	B	1.5	2.4	16	-	5	3	2.6	2.9	1.35	3.7	3.9	2.1	3.0	2.0	6.1	0.2	16						
0-1452659-1	B	1.5	2.4	-	1.5	5	3	2.6	2.9	1.35	3.7	3.9	2.1	3.0	2.0	6.1	0.2	16						

0- VARIANTS SUPERSEDED BY 7- VARIANTS (SEE TABLE ON TOP)

THIS DRAWING IS A CONTROLLED DOCUMENT. **STE** TE Connectivity

OWNER: E. Horn 11NOV2011
 CHK: R. Meier 11NOV2011
 APVD: V. Seigel 11NOV2011

NAME: MCON 1.2 LL (LOCKING-LANCE)

PRODUCT SPEC: 108-18782
 APPLICATION SPEC: 114-18464

SIZE: A1 CAGE CODE: 00779 DRAWING NO: 1452674 RESTRICTED TO: -
 WEIGHT: - SCALE: - SHEET: 2 OF 2 REV: C7

Customer Drawing

1. SCOPE	3	1. ANWENDUNGSBEREICH	3
1.1. Content.....	3	1.1. Inhalt.....	3
1.2. Qualification	3	1.2. Qualifikation.....	3
1.3. Application Area.....	3	1.3. Einsatzgebiet	3
2. APPLICABLE DOCUMENTS	3	2. ANWENDBARE UNTERLAGEN	3
2.1. TE Connectivity Documents.....	3	2.1. TE Connectivity Unterlagen	3
2.2. General Documents	3	2.2. Allgemeine Unterlagen	3
3. REQUIREMENTS	4	3. ANFORDERUNGEN	4
3.1. Design and construction.....	4	3.1. Entwurf und Konstruktion	4
3.2. Materials.....	4	3.2. Werkstoffe	4
3.3. Technical Data	4	3.3. Technische Daten.....	4
3.4. Performance and Test Description	4	3.4. Leistungsmerkmale und Testbeschreibung	4
3.5. Test Requirements and Procedures by Motor Vehicle Connectors Test Specification LV214	6	3.5. Anforderungen und Prüfungen nach Prüfvorschrift für KFZ-Steckverbinder LV214	10
4. APPENDIX	14	4. ANHANG	14
REVISION RECORD	21	REVISION RECORD	21

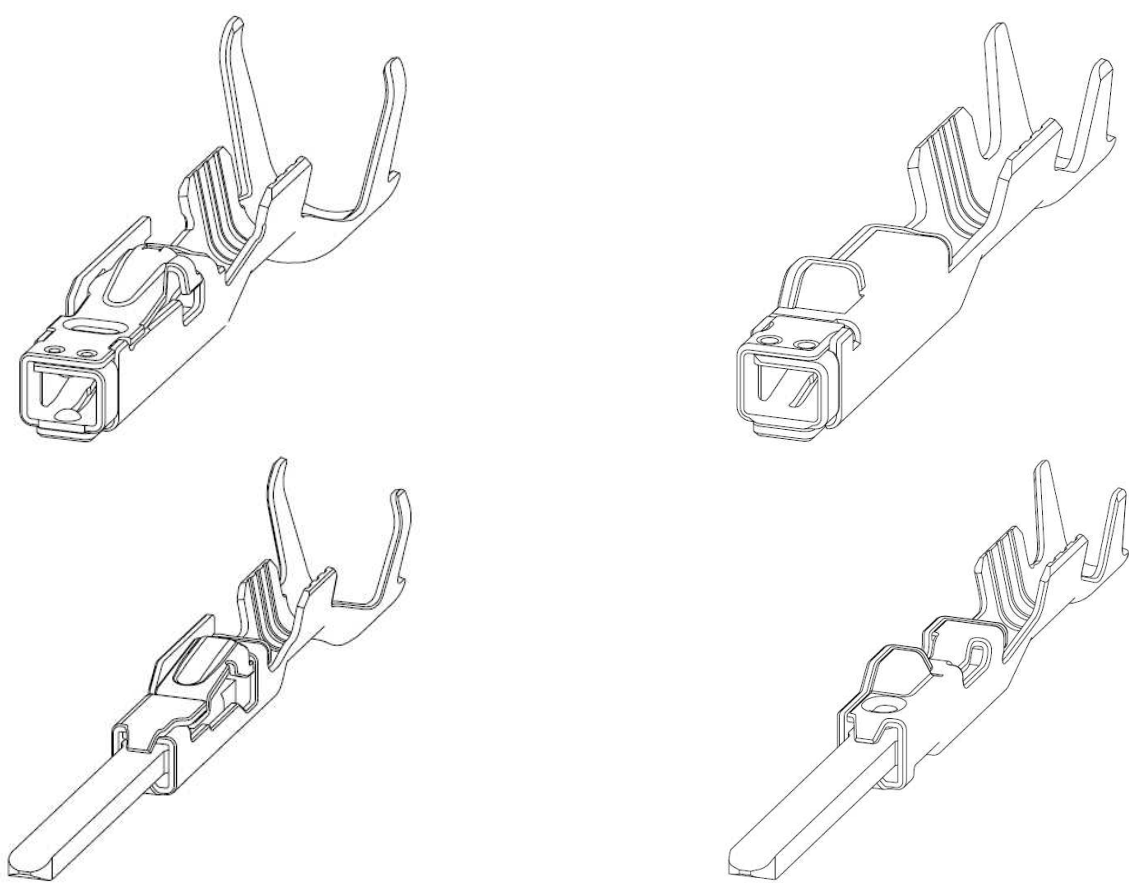



<p>1. SCOPE</p> <p><i>1.1. Content</i></p> <p>This specification describes the characteristic, tests and quality requirements for the MCON 1.2 Contact System</p> <p><i>1.2. Qualification</i></p> <p>When testing the named products the following specified specifications and standards shall be used. All tests have to be done using the applicable inspection plan and product.</p> <p><i>1.3. Application Area</i></p> <p>The contact is designed to carry medium currents in motor vehicles, in which vibration and mechanical stress may affect the reliability of conventional contacts.</p>	<p>1. ANWENDUNGSBEREICH</p> <p><i>1.1. Inhalt</i></p> <p>Diese Spezifikation beschreibt die Eigenschaften, Tests und Qualitätsanforderungen für das MCON 1.2 Kontaktsystem</p> <p><i>1.2. Qualifikation</i></p> <p>Bei der Prüfung der genannten Produkte sind die nachfolgend genannten Richtlinien und Normen zu verwenden. Alle Prüfungen müssen nach den zugehörigen Prüfplänen und Produktzeichnungen durchgeführt werden.</p> <p><i>1.3. Einsatzgebiet</i></p> <p>Das Kontaktsystem ist für mittlere Ströme in Kraftfahrzeugen entwickelt, bei der Vibration und mechanische Belastungen die Zuverlässigkeit herkömmlicher Kontaktsysteme auf Dauer beeinflussen kann.</p>
<p>2. APPLICABLE DOCUMENTS</p> <p>The following documents, if they are referred inside this document, are part of this specification. In case of conflict between the requirements of this specification and the product drawing or in conflict between the requirements of this specification and the referenced documents, this specification has precedence. In case of discrepancies the German text is valid.</p> <p><i>2.1. TE Connectivity Documents</i></p> <p>A 109-1: General Requirements for Test Specifications</p> <p>B Customer Drawings and Naming 1452674 MCON 1.2 LL* 1534326 MCON 1.2 CB** 1418754 Tab Contact 1.2 LL* 1718398 Tab Contact 1.2 CB** 1563888 MCON 1.2 LL* for short circuit application } NOT FOR NEW APPLICATIONS</p> <p>C 114-18464 Application Specification</p> <p>D 114-94201 Contact Pins and Tabs for Shrouded Connection</p>	<p>2. ANWENDBARE UNTERLAGEN</p> <p>Die nachfolgend genannten Unterlagen, sofern im Dokument darauf verwiesen wird, sind Teil dieser Spezifikation. Im Falle des Widerspruches zwischen dieser Spezifikation und der Produktzeichnung oder des Widerspruches zwischen dieser Spezifikation und den aufgeführten Unterlagen hat diese Spezifikation Vorrang. Im Falle von Unstimmigkeiten gilt der deutsche Text.</p> <p><i>2.1. TE Connectivity Unterlagen</i></p> <p>A 109-1: Generelle Anforderungen für die Testdurchführungen</p> <p>B Kundenzeichnungen und Benennungen 1452674 MCON 1.2 LL* 1534326 MCON 1.2 CB** 1418754 Flachstecker 1.2 LL* 1718398 Flachstecker 1.2 CB** 1563888 MCON 1.2 LL* für Kurzschlussfederanwendung } NICHT FÜR NEUANWENDUNGEN</p> <p>C 114-18464 Verarbeitungsspezifikation</p> <p>D 114-94201 Kontaktstifte und Messer für Kragenanschluss</p>
<p><i>2.2. General Documents</i></p> <p>A IEC 60512 Connectors for electronic equipment, Tests and measurements</p> <p>B IEC 60068 Environmental testing</p> <p>C Test Guideline for Motor Vehicle Connectors LV214 Edition March 2010, representative for the specifications VW 75174 (2018-06); MBN 10384 (2010-11); GD 95006-7-1 (2016-03)</p> <p>D Test Guideline for Motor Vehicle Connectors Edition 1 - 04.96</p> <p>E IEC 60760 Flat, quick-connect terminations</p>	<p><i>2.2. Allgemeine Unterlagen</i></p> <p>A IEC 60512 Steckverbinder für elektronische Einrichtungen, Mess- und Prüfverfahren</p> <p>B IEC 60068 Umgebungseinflüsse</p> <p>C Prüfvorschrift für KFZ - Steckverbinder LV214 Ausgabe März 2010, stellvertretend für die Spezifikationen VW 75174 (2018-06); MBN 10384 (2010-11); GD 95006-7-1 (2016-03)</p> <p>D Prüfrichtlinie für KFZ – Steckverbinder Ausgabe 1 - 04.96</p> <p>E IEC 60760 Flachsteckverbindungen</p>

* LL – Locking Lance / Rastfeder
** CB – Clean Body

<p>3. REQUIREMENTS</p> <p><i>3.1. Design and construction</i></p> <p>The product must correspond with the product drawing, concerning the design and the physical dimensions. The counterpart has to be according specification 114-94201 for Tab 1.2x0.6.</p> <p><i>3.2. Materials</i></p> <p>Information on this can be found on the product drawings.</p>	<p>3. ANFORDERUNGEN</p> <p><i>3.1. Entwurf und Konstruktion</i></p> <p>Das Produkt muss in seiner Ausführung und seinen physikalischen Abmessungen der Produktzeichnung entsprechen. Das Gegenstück muss der Spezifikation 114-94201 für Tab 1.2x0.6 entsprechen.</p> <p><i>3.2. Werkstoffe</i></p> <p>Angaben hierzu sind den Zeichnungsunterlagen zu entnehmen.</p>
<p><i>3.3. Technical Data</i></p> <p>A Nominal voltage according to IEC 664 / IEC 60664A (DIN VDE0110)</p> <p>B Current carrying capability see derating curves in appendix</p> <p>C Temperature range depends on plating of MCON 1.2 receptacle and used tab (ambient temperature plus temperature rise due to electrical heating):</p> <p>From -40 °C to 130 °C for MCON 1.2 (SnAg) mated with tab 1.2mm (Sn)</p> <p>From -40 °C to 150 °C for MCON 1.2 (SnAg) mated with tab 1.2mm (Ag) for MCON 1.2 (Ag) mated with tab 1.2mm (Ag) for MCON 1.2 (Au) mated with tab 1.2mm (Au)</p> <p>From -40 °C to 170 °C for MCON 1.2 (Ag) mated with tab 1.2mm (Ag with Ni-underlayer)</p> <p>For the application with limit temperature >150°C using appropriate counterpart note 5 of specification 114-94201 shall be applied</p>	<p><i>3.3. Technische Daten</i></p> <p>A Nennspannung nach IEC 60664 / IEC 60664 (DIN VDE0110)</p> <p>B Strombelastbarkeit siehe Deratingkurven im Anhang</p> <p>C Temperaturbereich ist abhängig von der Beschichtung des MCON 1.2 Buchsenkontakts und des verwendeten Tabs (Umgebungstemperatur plus Stromerwärmung):</p> <p>Von -40 °C bis 130 °C für MCON 1.2 (SnAg) gesteckt auf Tab 1.2mm (Sn)</p> <p>Von -40 °C bis 150 °C für MCON 1.2 (SnAg) gesteckt auf Tab 1.2mm (Ag) für MCON 1.2 (Ag) gesteckt auf Tab 1.2mm (Ag) für MCON 1.2 (Au) gesteckt auf Tab 1.2mm (Au)</p> <p>Von -40 °C bis 170 °C für MCON 1.2 (Ag) gesteckt auf Tab 1.2mm (Ag, unternickelt)</p> <p>Bei Anwendungen mit Grenztemperaturen >150°C mit entsprechendem Gegenstecker gilt Bemerkung 5 der Spezifikation 114-94201</p>
<p><i>3.4. Performance and Test Description</i></p> <p>The product fulfills the electrical, mechanical and environmental performance requirements according motor vehicle connectors test specification LV214 (edition March 2010) given in paragraph 3.5. All tests are performed at ambient environmental conditions per DIN IEC 60512 unless otherwise specified.</p> <p>The following table shows which variants meet the requirements of LV214-2 / slow-motion test, USCAR-2 / Rev. 6 and USCAR 21 / Rev. 2.</p>	<p><i>3.4. Leistungsmerkmale und Testbeschreibung</i></p> <p>Das Produkt erfüllt die in Abschnitt 3.5 aufgeführten elektrischen, mechanischen und klimatischen Anforderungen nach der Prüfvorschrift für KFZ-Steckverbinder LV214 (Ausgabe März 2010). Soweit nicht anders spezifiziert, sind alle Prüfungen unter den in der DIN IEC 60512 genannten Umweltbedingungen durchgeführt. Die folgende Tabelle zeigt, welche Varianten den Anforderungen gemäß LV214-2 / Slow-Motion-Prüfung, USCAR-2 / Rev. 6 und USCAR 21 / Rev. 2 entsprechen</p>

	Receptacle / Buchse		Tab / Stiftkontakt			
	LL ("7-" variant)	CB	LL ("0-" variant)	LL ("5-" variant)	CB	
<i>Body material:</i>	<i>CuSn4</i>	<i>CuSn0.15</i>	<i>CuNiSi</i>	<i>CuNiSi</i>	<i>CuSn0.15</i>	<i>CuSn4</i>
<i>SMBT</i>	X	*	*	*	*	-
<i>USCAR-21</i>	*	*	-	-	*	X

X all wire sizes validated
 * partially validated

X alle Drahtgrößen validiert
 * teilweise validiert

3.4.1. General Requirements

All tests meet the test procedures and test guidelines.

- Number of samples: see LV214
- The specified tools must be used for the mechanical tests
- The specimen must be free of visible damage
- The specimen must comply with the actual drawings
- For testing series production parts shall be used only
- Tests are for the tested combination only (contact, tab, wire, housings), other designs (geometry, material) must be tested separately and are consequently not released
- The wires used must have a watertight isolation and sufficiently heat resistance, if applicable. The wires used must be free of damage, holes and grooves
- For leak tests, standard rods whose diameter correspond to a worst-case wire shall be used instead of FLR wires. In individual cases, the transferability of the results to wire insulation materials with sufficient temperature resistance must be proved by tests
- Mating cycles depend on various technical influences and must be confirmed in each individual case
- Speed for mechanical tests: 50mm/min.
- The contact parts must be processed with TE-tools
- Processing of the contacts acc. spec. 114-18464
- Vibration examinations are valid for the products tested only; deviating designs shall be examined separately and are consequently not released

3.4.1. Allgemeine Testbedingungen

Aufgeführte Tests entsprechen den angegebenen Prüfverfahren und Prüfrichtlinien.

- Anzahl der Prüflinge: siehe LV214
- Für die mechanischen Tests sind die genannten Hilfswerkzeuge zu verwenden
- Die Prüflinge dürfen mit bloßem Auge keine sichtbaren Beschädigungen aufweisen
- Die Prüflinge müssen dem aktuellen Zeichnungsstand entsprechen
- Für Prüfzwecke sind nur Serienteile zu verwenden
- Durchgeführte Prüfungen gelten nur für die getesteten Kombinationen (Kontakt, Tab-Kontakt, Kabel, Gehäuse), abweichende Designs (Geometrie, Materialien) sind separat zu testen und sind somit nicht freigegeben
- Die verwendeten Leitungen müssen, wenn anwendbar, eine wasserdichte Isolation aufweisen, ausreichende Wärmeformbeständigkeit besitzen und frei von Beschädigungen, Löchern und Riefen sein
- Bei Dichtheitsprüfungen werden anstelle der FLR-Leitungen Urstäbe, die im Durchmesser einer Worst-Case-Leitung entsprechen, als Leitungsnachbildung verwendet. Die Übertragbarkeit auf ausreichend temperaturbeständige Leitungsisolationsmaterialien muss im Einzelfall durch Tests nachgewiesen werden
- Die Anzahl der Steckzyklen ist abhängig von vielen technischen Einflüssen und sollte für jeden Einzelfall überprüft werden
- Prüfgeschwindigkeit für mech. Tests: 50mm/min.
- Für die Verarbeitung der Kontaktteile sind TE-Werkzeuge zu verwenden
- Verarbeitung der Kontakte nach Spez. 114-18464
- Vibrationsprüfungen gelten nur für die getesteten Produkte, abweichende Designs sind separat zu prüfen und sind somit nicht freigegeben

3.5. Test Requirements and Procedures by Motor Vehicle Connectors Test Specification LV214 (Edition March 2010)

Test description	Requirement	Procedure / Notes																		
PG 0 Receiving inspection E 0.1 Visual and dimensional inspection E 0.2.1 Contact resistance in contact area E 0.2.2 Contact resistance in connection area	Drawing Conformance Contact resistance in contact area (R_K) $R_K \leq 2m\Omega$ Contact resistance in connection area (R_C) <table border="1"> <thead> <tr> <th>Body material [mm²]</th> <th>CuSn0.15 [mΩ]</th> <th>CuNiSi [mΩ]</th> <th>CuSn4 [mΩ]</th> </tr> </thead> <tbody> <tr> <td>(0.13 - 0.22)</td> <td></td> <td>$R_C \leq 4.2$</td> <td rowspan="4">} $R_C \leq 1.5$</td> </tr> <tr> <td>(>0.22 - 0.5)</td> <td>$R_C \leq 1.0$</td> <td>$R_C \leq 2.2$</td> </tr> <tr> <td>(>0.5 - 1.0)</td> <td>$R_C \leq 0.8$</td> <td>$R_C \leq 1.2$</td> </tr> <tr> <td>(>1.0 - 1.5)</td> <td>$R_C \leq 0.6$</td> <td>$R_C \leq 0.8$</td> <td>$R_C \leq 1.0$</td> </tr> </tbody> </table>	Body material [mm ²]	CuSn0.15 [mΩ]	CuNiSi [mΩ]	CuSn4 [mΩ]	(0.13 - 0.22)		$R_C \leq 4.2$	} $R_C \leq 1.5$	(>0.22 - 0.5)	$R_C \leq 1.0$	$R_C \leq 2.2$	(>0.5 - 1.0)	$R_C \leq 0.8$	$R_C \leq 1.2$	(>1.0 - 1.5)	$R_C \leq 0.6$	$R_C \leq 0.8$	$R_C \leq 1.0$	DIN EN 60512-1-1 DIN EN 60512-2-1 <i>Limits for R_C acc. to</i> DIN EN 60352-2 APR2014
Body material [mm ²]	CuSn0.15 [mΩ]	CuNiSi [mΩ]	CuSn4 [mΩ]																	
(0.13 - 0.22)		$R_C \leq 4.2$	} $R_C \leq 1.5$																	
(>0.22 - 0.5)	$R_C \leq 1.0$	$R_C \leq 2.2$																		
(>0.5 - 1.0)	$R_C \leq 0.8$	$R_C \leq 1.2$																		
(>1.0 - 1.5)	$R_C \leq 0.6$	$R_C \leq 0.8$		$R_C \leq 1.0$																
PG 4 Contact overlapping	$\geq 1,0mm$ (depends on Tab and Housing design) Acc. - AK-Drawing for Contact Pins and Tabs for Shrouded Connection 114-94201 - AK-Standard Contact Cavity for <table border="0"> <tr> <td>MCON 1.2 LL</td> <td>Receptacle 115-18064 Tab 115-18130</td> </tr> <tr> <td>MCON 1.2 CB</td> <td>Receptacle 115-18063 Tab 115-18167</td> </tr> </table>	MCON 1.2 LL	Receptacle 115-18064 Tab 115-18130	MCON 1.2 CB	Receptacle 115-18063 Tab 115-18167	<i>Theoretical proof front edge contact (rear edge contact in the interference)</i>														
MCON 1.2 LL	Receptacle 115-18064 Tab 115-18130																			
MCON 1.2 CB	Receptacle 115-18063 Tab 115-18167																			
PG 5 Mechanical and thermal relaxation behavior E 5.2 Contact normal force B 5.3 Aging in dry heat, inserted	New: min. 3.0N after temperature storage: min. 1.0N	DIN EN 60068-2-2 +150°C, 1000h																		
PG 8 Contact retention force E 8.2.1 Primary lock only E 8.2.2 Secondary lock only Pull-out force out of steel cavity	Primary lock displacement: $s \leq 1mm$ min. 55N (Type MCON 1.2 LL; TAB 1.2 LL) min. 40N (Type MCON 1.2 CB; TAB 1.2 CB) min. 55N min. 75N (Type MCON 1.2 CB) min. 60N (Type MCON 1.2 LL) min. 55N (Type TAB 1.2 LL) min. 75N (Type TAB 1.2 CB)	<i>The pull-out forces are also influenced by the housing material and should therefore be taken from the respective housing specification.</i>																		
PG 10 Conductor pull-out strength E 10.1 Conductor pull-out strength	Insulation crimp inactive $\geq 50N$ (0.13 - 0.22mm ²) ¹ $\geq 50N$ (0.35mm ²) $\geq 60N$ (0.5mm ²) $\geq 85N$ (0.75mm ²) $\geq 108N$ (1.0mm ²) $\geq 150N$ (1.5mm ²)																			

¹ Reinforced wire according to LV 112-4 and 114-18464

<p>PG 11 Insertion and removal forces, mating cycle frequency</p> <p>E 11.1 Mating and unmating forces with steel tab</p> <p>E 11.1 Typical values for mating and unmating forces calculation in application (For information only)</p> <p>B 11.1 Mating cycle frequency</p>	<p>Mating / unmating force for single terminal at first mating cycle with steel tab</p> <p>Mating: max. 4.5N Unmating: max. 3.0N</p> <p>Mating / unmating force² for single terminal at first mating cycle with real tab</p> <table border="1" data-bbox="550 593 1053 828"> <thead> <tr> <th>Material</th> <th>95% confidence level *)</th> <th>average</th> </tr> </thead> <tbody> <tr> <td>Sn/ SnAg</td> <td>5.3 N</td> <td>3.9 N</td> </tr> <tr> <td>Ag</td> <td>5.1 N</td> <td>2.8 N</td> </tr> <tr> <td>Au</td> <td>3.6 N</td> <td>3.1 N</td> </tr> </tbody> </table> <p>Mating cycles³</p> <p>Sn / SnAg = min. 20 Ag = min. 20 Au = min. 100</p> <p>mating force variation > 25% acceptable</p>	Material	95% confidence level *)	average	Sn/ SnAg	5.3 N	3.9 N	Ag	5.1 N	2.8 N	Au	3.6 N	3.1 N	<p>with reference tab acc. TE-PN 1355893-5</p> <p>*) The force values for the real tab are reference values derived from experiential data. Valid for 95% of the measured data when using counterparts such as below mentioned and are used to calculate the maximum mating and unmating force.</p> <p>Mating cycle frequency valid when using MCON 1.2 tab terminals such as</p> <p>Sn: PN 5-1418760-1 Ag: PN 0-1718758-3 Au: PN 5-1418760-2</p>
Material	95% confidence level *)	average												
Sn/ SnAg	5.3 N	3.9 N												
Ag	5.1 N	2.8 N												
Au	3.6 N	3.1 N												
<p>PG 12 Current temperature rise, derating (without housing)</p>	<p>See temperature rise and derating curves in appendix 4.1</p>	<p>DIN EN 60512-5-2</p>												
<p>PG 13 Effect of housing on derating</p>	<p>depends on loading condition and used housing; the verification has to be done for each housing and each loading condition separately</p> <p>Temperature rise and derating curve for exemplary application in appendix 4.2</p>	<p>DIN EN 60512-5-1/2</p>												
<p>PG 14 Thermal time constant</p>	<p>Diagrams for short term current overload in appendix 4.3</p>	<p>1-/2-/3-/4- and 5-times the rated current</p>												
<p>PG 15 Electrical stress test</p> <p>B 15.2 Temperature / current cycle endurance test</p> <p>B 15.3 Humid heat, cyclic</p> <p>E 0.2 Connection resistance</p>	<p>Limit temperature for⁴ Sn = 130 °C; Ag, Au = 150 °C; Au = 170 °C (T_o + current temperature rise)</p> <p>$\Delta I \leq 0,2 \times I_{ini}$ at 80°C</p> <p>contact + 2x crimp resistance acc. LV214 appendix D:</p> <table border="0" data-bbox="550 1870 1037 1960"> <tr> <td>(0.13-0.22mm²)</td> <td>R_{max}=20mΩ</td> </tr> <tr> <td>(0.35, 0.5, 0.75, 1.0mm²)</td> <td>R_{max}=15mΩ</td> </tr> <tr> <td>(1.5mm²)</td> <td>R_{max}=10mΩ</td> </tr> </table>	(0.13-0.22mm ²)	R _{max} =20mΩ	(0.35, 0.5, 0.75, 1.0mm ²)	R _{max} =15mΩ	(1.5mm ²)	R _{max} =10mΩ	<p>Duration: 60 cycles (1 cycle = 6h) - 40°C / T_o T_o = upper temperature in the climate chamber</p> <p>DIN EN 60068-2-30 T_U=25°C / T_o=55°C rel. humidity 95% 1 cycle = 24h, 21 cycles</p> <p>DIN EN 60512-2-1</p>						
(0.13-0.22mm ²)	R _{max} =20mΩ													
(0.35, 0.5, 0.75, 1.0mm ²)	R _{max} =15mΩ													
(1.5mm ²)	R _{max} =10mΩ													

² The mating/unmating force is dependent on the tribological properties of the surfaces and geometries used in each case. When using the TE Connectivity produced and delivered surfaces and contact geometries, female and male side, the referenced force values are valid.

³ The maximum number of mating cycles is dependent on the tribological properties of the surfaces used in each case. Only when using the TE Connectivity produced and delivered surfaces and contact geometries, female and male side, the maximum number of mating cycles can be assured.

⁴ See 3.3 which variants and tabs shall be used

<p>PG 17 Dynamic stress</p> <p>B 17.1 Sinusoidal B 17.2 Broadband random vibration B 17.3 Endurance shock test</p> <p>E 0.2 Connection resistance</p>	<p>Potential severity levels for</p> <p>Sn / SnAg: up to severity 2 Ag: up to severity 4 Au: up to severity 3</p> <p>The dynamic stress severity depends on operational area and the housing used; the verification has to be done for each housing and each site of operation separately</p> <p>Circuit interruption monitoring: no interruptions $\geq 7\Omega$ / $\geq 1\mu\text{s}$</p> <p>contact + 2x crimp resistance acc. LV214 appendix D: (0.13-0.22mm²) $R_{\text{max}}=20\text{m}\Omega$ (0.35, 0.5, 0.75, 1.0mm²) $R_{\text{max}}=15\text{m}\Omega$ (1.5mm²) $R_{\text{max}}=10\text{m}\Omega$</p>	<p>DIN EN 60068-2-6 DIN EN 60068-2-64 DIN EN 60068-2-27</p> <p>Severity levels acc. LV 214 PG 17, table 7:</p> <p>Severity 1: „Body unsealed“ Severity 2: „Body sealed“ Severity 3: „Applications close to Powertrain“ Severity 4: „Engine-mounted parts“</p> <p>DIN EN 60512-2-1</p>
<p>PG 18A Coastal climate test</p> <p>B 18.2 Salt spray, cyclic</p> <p>E 0.2 Connection resistance</p>	<p>Severity 3</p> <p>contact + 2x crimp resistance acc. LV214 appendix D: (0.13-0.22mm²) $R_{\text{max}}=20\text{m}\Omega$ (0.35, 0.5, 0.75, 1.0mm²) $R_{\text{max}}=15\text{m}\Omega$ (1.5mm²) $R_{\text{max}}=10\text{m}\Omega$</p>	<p>DIN EN 60068-2-52</p> <p>1 cycle = 2h salt spray / 35°C + 22h 40°C / 93% rel. humidity</p> <p>4 cycles + 72h storage at 23°C</p> <p>DIN EN 60512-2-1</p>
<p>PG 19 Environmental simulation</p> <p>B 19.1 Temperature shock B 19.2 Temperature cycle B 19.3 Aging in dry heat B 19.4 Industrial climate (multiple-component climate) B 19.5 Humidity heat, cyclic</p> <p>E 0.2 Connection resistance</p>	<p>No corrosion must occur in the area of the contact zone</p> <p>Rubbing through is not permissible in the contact area</p> <p>contact + 2x crimp resistance acc. LV214 appendix D: (0.13-0.22mm²) $R_{\text{max}}=20\text{m}\Omega$ (0.35, 0.5, 0.75, 1.0mm²) $R_{\text{max}}=15\text{m}\Omega$ (1.5mm²) $R_{\text{max}}=10\text{m}\Omega$</p> <p>Requirements of procedure B 19.1 – B 19.5 fulfilled</p>	<p>DIN EN 60068-2-14 Na -40°C / +130°C each 15min, 144 cycles</p> <p>DIN EN 60068-2-14 Nb -40°C / +130°C each 3h, 20 cycles</p> <p>DIN EN 60068-2-2 Bb 130°C / 120h</p> <p>DIN EN 60068-2-60 / method 4 0.2ppm SO₂, 0.01ppm H₂S, 0.2ppm NO₂, 0.01ppm Cl₂ 25°C / 75% rel. humidity 21d, Volume flow = 1m³/h</p> <p>DIN EN 60068-2-30 Db Var. 2 25°C / 55°C, rel. humidity 95%, 10 cycles each 24h</p> <p>DIN EN 60512-2-1</p>



PG 21 Long-term temperature aging		
B 21.1 Long-term aging in dry heat		DIN EN 60068-2-2 B <i>130°C / 1000h, RT / 48h</i>
E 0.2 Contact resistance	contact + 2x crimp resistance acc. LV214 appendix D: (0.5, 0.75, 1.0mm ²) R _{max} =15mΩ (1.5mm ²) R _{max} =10mΩ	
E 8.2 Contact pull-out forces ⁵	From housing (primary and secondary lock closed) min. 55 N	

⁵ The pull-out force for the MCON 1.2 LL is largely dependent on the materials of the housing and secondary lock. When using housings sold from TE connectivity and specified for the MCON 1.2 LL the referenced value is valid.

3.5. Anforderungen und Prüfungen nach Prüfvorschrift für KFZ-Steckverbinder LV214 (Ausgabe März 2010)

Beschreibung	Anforderung	Prüfverfahren / Bemerkungen																		
PG 0 Eingangsprüfung E 0.1 Sicht- und Maßprüfung E 0.2.1 Durchgangswiderstand im Kontaktbereich E 0.2.2 Durchgangswiderstand im Anschlussbereich	Zeichnungskonformität Kontaktdurchgangswiderstand (R_K) $R_K \leq 2m\Omega$ Crimpdurchgangswiderstand (R_C) <table border="1"> <thead> <tr> <th>Body material [mm²]</th> <th>CuSn0.15 [mΩ]</th> <th>CuNiSi [mΩ]</th> <th>CuSn4 [mΩ]</th> </tr> </thead> <tbody> <tr> <td>(0.13 - 0.22)</td> <td></td> <td>$R_C \leq 4.2$</td> <td rowspan="4">} $R_C \leq 1.5$</td> </tr> <tr> <td>(>0.22 - 0.5)</td> <td>$R_C \leq 1.0$</td> <td>$R_C \leq 2.2$</td> </tr> <tr> <td>(>0.5 - 1.0)</td> <td>$R_C \leq 0.8$</td> <td>$R_C \leq 1.2$</td> </tr> <tr> <td>(>1.0 - 1.5)</td> <td>$R_C \leq 0.6$</td> <td>$R_C \leq 0.8$</td> <td>$R_C \leq 1.0$</td> </tr> </tbody> </table>	Body material [mm ²]	CuSn0.15 [mΩ]	CuNiSi [mΩ]	CuSn4 [mΩ]	(0.13 - 0.22)		$R_C \leq 4.2$	} $R_C \leq 1.5$	(>0.22 - 0.5)	$R_C \leq 1.0$	$R_C \leq 2.2$	(>0.5 - 1.0)	$R_C \leq 0.8$	$R_C \leq 1.2$	(>1.0 - 1.5)	$R_C \leq 0.6$	$R_C \leq 0.8$	$R_C \leq 1.0$	DIN EN 60512-1-1 DIN EN 60512-2-1 Grenzwerte für R_C nach DIN EN 60352-2 APR2014
Body material [mm ²]	CuSn0.15 [mΩ]	CuNiSi [mΩ]	CuSn4 [mΩ]																	
(0.13 - 0.22)		$R_C \leq 4.2$	} $R_C \leq 1.5$																	
(>0.22 - 0.5)	$R_C \leq 1.0$	$R_C \leq 2.2$																		
(>0.5 - 1.0)	$R_C \leq 0.8$	$R_C \leq 1.2$																		
(>1.0 - 1.5)	$R_C \leq 0.6$	$R_C \leq 0.8$		$R_C \leq 1.0$																
PG 4 Kontaktüberdeckung	$\geq 1,0mm$ (abhängig von Flachstecker- und Gehäusekonstruktion) Nach - AK-Zeichnung für Kontaktstifte und Messer für Kragenanschluss 114-94201 - AK-Standard Kontaktkammer für <table border="1"> <tbody> <tr> <td>MCON 1.2 LL</td> <td>Buchse</td> <td>115-18064</td> </tr> <tr> <td></td> <td>Tab</td> <td>115-18130</td> </tr> <tr> <td>MCON 1.2 CB</td> <td>Buchse</td> <td>115-18063</td> </tr> <tr> <td></td> <td>Tab</td> <td>115-18167</td> </tr> </tbody> </table>	MCON 1.2 LL	Buchse	115-18064		Tab	115-18130	MCON 1.2 CB	Buchse	115-18063		Tab	115-18167	<i>Theoretischer Nachweis Vorderer Kontaktpunkt (hinterer Kontaktpunkt im Eingriff)</i>						
MCON 1.2 LL	Buchse	115-18064																		
	Tab	115-18130																		
MCON 1.2 CB	Buchse	115-18063																		
	Tab	115-18167																		
PG 5 Mechanisches und thermisches Relaxationsverhalten E 5.2 Kontaktnormalkraft B 5.3 Lagerung bei trockener Wärme, gesteckt	Neuzustand: min. 3.0N Nach Temperaturlagerung: min. 1.0N	DIN EN 60068-2-2 +150°C, 1000h																		
PG 8 Kontakthaltekraft E 8.2.1 nur Primärverriegelung E 8.2.2 nur Sekundärverriegelung Abzugskraft aus Stahlkammer	Prüfungsweg Primärverriegelung: $s \leq 1mm$ min. 55N (Type MCON 1.2 LL; TAB 1.2 LL) min. 40N (Type MCON 1.2 CB; TAB 1.2 CB) min. 55N min. 75N (Type MCON 1.2 CB) min. 60N (Type MCON 1.2 LL) min. 55N (Type TAB 1.2 LL) min. 75N (Type TAB 1.2 CB)	<i>Kontakthaltekräfte werden auch vom Gehäusematerial beeinflusst und sollten deshalb der jeweiligen Gehäusespezifikation entnommen werden. Die angegebenen Werte sind beispielhaft und wurden an Gehäusen mit folgenden PNs nachgewiesen.</i> MCON 1.2 LL: PN 1-2141397-1 TAB 1.2 LL: PN 1801606-1 MCON 1.2 CB: PN 1488991-5 TAB 1.2 CB: PN 2203772-1																		
PG 10 Leiterausreißkraft E 10.1 Leiterausreißkraft	Isolationscrimp nicht aktiv <table border="1"> <tbody> <tr> <td>$\geq 50N$</td> <td>(0.13 - 0.22mm²)⁶</td> </tr> <tr> <td>$\geq 50N$</td> <td>(0.35mm²)</td> </tr> <tr> <td>$\geq 60N$</td> <td>(0.5mm²)</td> </tr> <tr> <td>$\geq 85N$</td> <td>(0.75mm²)</td> </tr> <tr> <td>$\geq 108N$</td> <td>(1.0mm²)</td> </tr> <tr> <td>$\geq 150N$</td> <td>(1.5mm²)</td> </tr> </tbody> </table>	$\geq 50N$	(0.13 - 0.22mm ²) ⁶	$\geq 50N$	(0.35mm ²)	$\geq 60N$	(0.5mm ²)	$\geq 85N$	(0.75mm ²)	$\geq 108N$	(1.0mm ²)	$\geq 150N$	(1.5mm ²)							
$\geq 50N$	(0.13 - 0.22mm ²) ⁶																			
$\geq 50N$	(0.35mm ²)																			
$\geq 60N$	(0.5mm ²)																			
$\geq 85N$	(0.75mm ²)																			
$\geq 108N$	(1.0mm ²)																			
$\geq 150N$	(1.5mm ²)																			

⁶ Zugverstärkte Leitung nach LV 112-4 und 114-18464

<p>PG 11 Steck- und Ziehkräfte, Steckhäufigkeit</p> <p>E 11.1 Steck- und Ziehkraft mit Stahl Tab</p> <p>E 11.1 Typische Werte zur Berechnung der Steck- und Ziehkräfte in der Applikation (Nur zur Information)</p> <p>B 11.1 Steckhäufigkeit</p>	<p>Steck- / Ziehkraft für einen Kontakt beim ersten Steckzyklus mit Stahl Tab</p> <p>Steckkraft: max. 4.5N Ziehkraft: max. 3.0N</p> <p>Steck- / Ziehkraft⁷ für einen Kontakt beim ersten Steckzyklus mit Real Tab</p> <table border="1" data-bbox="550 645 1077 884"> <thead> <tr> <th>Material</th> <th>95% Konfidenzintervall *)</th> <th>Mittelwert</th> </tr> </thead> <tbody> <tr> <td>Sn/ SnAg</td> <td>5.3 N</td> <td>3.9 N</td> </tr> <tr> <td>Ag</td> <td>5.1 N</td> <td>2.8 N</td> </tr> <tr> <td>Au</td> <td>3.6 N</td> <td>3.1 N</td> </tr> </tbody> </table> <p>Steckzyklen⁸</p> <p>Sn / SnAg = min. 20 Ag = min. 20 Au = min. 100</p> <p>Steckkraftveränderung > 25% zulässig</p>	Material	95% Konfidenzintervall *)	Mittelwert	Sn/ SnAg	5.3 N	3.9 N	Ag	5.1 N	2.8 N	Au	3.6 N	3.1 N	<p>Mit Prüfflachstecker nach TE-PN 1355893-5</p> <p><i>*) Die Kraftwerte mit Real Tab sind von Versuchsdaten abgeleitete Referenzwerte, die für 95% der gemessenen Daten gelten, wenn die unten genannten Gegenstecker verwendet werden und dienen zur Berechnung der maximalen Steck- und Ziehkräfte.</i></p> <p>Anzahl an Steckzyklen / oben angegebene Kraftwerte mit Real Tab gültig bei Verwendung von MCON 1.2 Flachsteckern wie bspw.</p> <p>Sn: PN 5-1418760-1 Ag: PN 0-1718758-3 Au: PN 5-1418760-2</p>
Material	95% Konfidenzintervall *)	Mittelwert												
Sn/ SnAg	5.3 N	3.9 N												
Ag	5.1 N	2.8 N												
Au	3.6 N	3.1 N												
<p>PG 12 Stromerwärmung, Derating (ohne Gehäuse)</p>	<p>Siehe Stromerwärmung und Deratingkurven in Anhang 4.1</p>	<p>DIN EN 60512-5-2</p>												
<p>PG 13 Gehäuseeinfluss auf das Derating</p>	<p>abhängig vom Lastfall und verwendetem Gehäuse; die Prüfung ist jeweils für die eingesetzten Gehäuse und den Lastfall speziell durchzuführen</p> <p>Stromerwärmung und Deratingkurve für Anwendungsbeispiel in Anhang 4.2</p>	<p>DIN EN 60512-5-1/2</p>												
<p>PG 14 Thermische Zeitkonstante</p>	<p>Diagramme für thermische Zeitkonstante in Anhang 4.3</p>	<p>1-/2-/3-/4- und 5-facher Nennstrom</p>												

⁷ Die Steck- / Ziehkräfte hängen von den tribologischen Eigenschaften der jeweils verwendeten Oberflächen und Geometrien ab. Nur bei Verwendung der von TE Connectivity produzierten und gelieferten Oberflächen und Kontaktgeometrien, buchsen- und stiftseitig, gelten die angegebenen Kraftwerte.

⁸ Die zulässige Anzahl der Steckzyklen ist abhängig von den tribologischen Eigenschaften der jeweils eingesetzten Oberflächen. Nur bei Verwendung der von TE Connectivity produzierten und gelieferten Oberflächen und Kontaktgeometrien, buchsen- und stiftseitig, kann die zulässige Anzahl Steckzyklen sichergestellt werden.

<p>PG 15 Elektrischer Stresstest</p> <p>B 15.2 Temperatur- / Stromwechselfestigkeit</p> <p>B 15.3 Feuchte Wärme, zyklisch</p> <p>E 0.2 Durchgangswiderstand</p>	<p>Grenztemperatur für⁹ Sn = 130 °C; Ag, Au = 150 °C; Ag = 170 °C (T_o + Stromerwärmung)</p> <p>$\Delta I \leq 0,2 \times I_{ini}$ bei 80°C</p> <p>Kontakt- + 2x Crimpdurchgangswiderstand nach LV214 Anhang D: (0.13-0.22mm²) R_{max}=20mΩ (0.35, 0.5, 0.75, 1.0mm²) R_{max}=15mΩ (1.5mm²) R_{max}=10mΩ</p>	<p>Dauer: 60 Zyklen (1 Zyklus = 6h) -40°C / T_o T_o = obere Temperatur im Klimaschrank</p> <p>DIN EN 60068-2-30 T_u=25°C / T_o=55°C rel. Feuchte 95% 1 Zyklus = 24h, 21 Zyklen</p> <p>DIN EN 60512-2-1</p>
<p>PG 17 Dynamische Beanspruchung</p> <p>B 17.1 Sinusförmig</p> <p>B 17.2 Breitbandrauschen</p> <p>B 17.3 Dauerschocken</p> <p>E 0.2 Durchgangswiderstand</p>	<p>Potenzielle Schärfegrade (SG) für Sn / SnAg: bis zu SG 2 Ag: bis zu SG 4 Au: bis zu SG 3</p> <p>Der Schärfegrad ist abhängig von dem Einsatzbereich und dem verwendeten Gehäuse; die Prüfung ist jeweils für die eingesetzten Gehäuse und den Einsatzort speziell durchzuführen</p> <p>Überwachung auf Stromunterbrechung: Keine Unterbrechungen $\geq 7\Omega / \geq 1\mu s$</p> <p>Kontakt- + 2x Crimpdurchgangswiderstand nach LV214 Anhang D: (0.13-0.22mm²) R_{max}=20mΩ (0.35, 0.5, 0.75, 1.0mm²) R_{max}=15mΩ (1.5mm²) R_{max}=10mΩ</p>	<p>DIN EN 60068-2-6 DIN EN 60068-2-64 DIN EN 60068-2-27</p> <p>Schärfegrade nach LV 214 PG 17, Tabelle 7: SG 1: „Karosserie ungedichtet“ SG 2: „Karosserie gedichtet“ SG 3: „Aggregatennahe Anwendung“ SG 4: „Motor-Anbauteile“</p> <p>DIN EN 60512-2-1</p>
<p>PG 18A Küstenklimabeanspruchung</p> <p>B 18.2 Salznebel, zyklisch</p> <p>E 0.2 Durchgangswiderstand</p>	<p>Schärfegrad 3</p> <p>Kontakt- + 2x Crimpdurchgangswiderstand nach LV214 Anhang D: (0.13-0.22mm²) R_{max}=20mΩ (0.35, 0.5, 0.75, 1.0mm²) R_{max}=15mΩ (1.5mm²) R_{max}=10mΩ</p>	<p>DIN EN 60068-2-52 1 Zyklus = 2h Salznebel / 35°C + 22h 40°C / 93% rel. Feuchte 4 Zyklen + 72h Lagerung bei 23°C</p> <p>DIN EN 60512-2-1</p>

⁹ See 3.3 which variants and tabs shall be used

<p>PG 19 Umweltsimulation</p> <p>B 19.1 Temperaturschock</p> <p>B 19.2 Temperaturwechsel</p> <p>B 19.3 Lagerung bei trockener Wärme</p> <p>B 19.4 Industrieklima (Mehrkomponentenklima)</p> <p>B 19.5 Feuchte Wärme, zyklisch</p> <p>E 0.2 Durchgangswiderstand</p>	<p>Im Bereich der Kontaktzone darf keine Korrosion auftreten</p> <p>Es ist kein Durchrieb im Kontaktbereich zulässig</p> <p>Kontakt- + 2x Crimpdurchgangswiderstand nach LV214 Anhang D:</p> <table border="0"> <tr> <td>(0.13-0.22mm²)</td> <td>R_{max}=20mΩ</td> </tr> <tr> <td>(0.35, 0.5, 0.75, 1.0mm²)</td> <td>R_{max}=15mΩ</td> </tr> <tr> <td>(1.5mm²)</td> <td>R_{max}=10mΩ</td> </tr> </table> <p>Anforderungen erfüllt für B 19.1 – B 19.5</p>	(0.13-0.22mm ²)	R _{max} =20mΩ	(0.35, 0.5, 0.75, 1.0mm ²)	R _{max} =15mΩ	(1.5mm ²)	R _{max} =10mΩ	<p>DIN EN 60068-2-14 Na -40°C / +130°C je 15min, 144 Zyklen</p> <p>DIN EN 60068-2-14 Nb -40°C / +130°C je 3h, 20 Zyklen</p> <p>DIN EN 60068-2-2 Bb 130°C / 120h</p> <p>DIN EN 60068-2-60 / Methode 4 0.2ppm SO₂, 0.01ppm H₂S, 0.2ppm NO₂, 0.01ppm Cl₂ 25°C / 75% rel. Feuchte 21d, Volumenstrom = 1m³/h</p> <p>DIN EN 60068-2-30 Db Var. 2 25°C / 55°C, rel. Feuchte 95%, 10 Zyklen zu je 24h</p> <p>DIN EN 60512-2-1</p>
(0.13-0.22mm ²)	R _{max} =20mΩ							
(0.35, 0.5, 0.75, 1.0mm ²)	R _{max} =15mΩ							
(1.5mm ²)	R _{max} =10mΩ							
<p>PG 21 Langzeittemperaturlagerung</p> <p>B 21.1 Langzeitlagerung bei trockener Wärme</p> <p>E 0.2 Durchgangswiderstand</p> <p>E 8.2 Kontaktauszugkräfte¹⁰</p>	<p>Kontakt- + 2x Crimpdurchgangswiderstand nach LV214 Anhang D:</p> <table border="0"> <tr> <td>(0.5, 0.75, 1.0mm²)</td> <td>R_{max}=15mΩ</td> </tr> <tr> <td>(1.5mm²)</td> <td>R_{max}=10mΩ</td> </tr> </table> <p>Aus Gehäuse (Primär- und Sekundärverriegelung geschlossen)</p> <p>min. 55 N</p>	(0.5, 0.75, 1.0mm ²)	R _{max} =15mΩ	(1.5mm ²)	R _{max} =10mΩ	<p>DIN EN 60068-2-2 B 130°C / 1000h, RT / 48h</p>		
(0.5, 0.75, 1.0mm ²)	R _{max} =15mΩ							
(1.5mm ²)	R _{max} =10mΩ							

¹⁰ Die Kontaktauszugskräfte beim MCON 1.2 LL hängen Großteiles von Geometrie und Material des verwendeten Gehäuses ab. Nur bei Verwendung von Gehäusen, die von TE Connectivity vertrieben werden, gelten die angegebenen Kraftwerte.

4. APPENDIX

4.1. Temperature rise / derating free in air

4. ANHANG

4.1. Stromerwärmung / Derating frei an Luft

Temperature rise / derating free in air Stromerwärmung / Derating frei in Luft		MCON 1.2 CB, 0.35 – 1.50 mm ²		
Wire/Leitung: *)	MCON 1.2 CB Material Body: CuSn0.15 / SnAg Insert: CuNiSi	Tab / Flachstecker 1.2 mm	Note / Bemerkung	Graph
0.35 mm ² FLR	1534594-1 / Sn	0-1718348-1 Material Body: CuSn0.15/0.20 / Sn Insert-Tab: CuSn0.15 / Sn	<p>For 130°C applications partly derived from 150°C applications / Für 130°C Anwendungen teilweise von 150°C Anwendungen abgeleitet</p>	①
0.50 mm ² FLR	1670144-1 / Sn	0-1718350-1 Material Body: CuSn0.15/0.20 / Sn Insert-Tab: CuSn0.15 / Sn		②
0.75 mm ² FLR	1670144-1 / Sn	0-1718350-1 Material Body: CuSn0.15/0.20 / Sn Insert-Tab: CuSn0.15 / Sn		③
1.00 mm ² FLR	1452503-3 / Ag	0-2177610-3 Material Body: CuSn4 / Sn Insert-Tab: CuSn0.15 / Ag		④
1.50 mm ² FLR	1452503-3 / Ag	0-2177610-3 Material Body: CuSn4 / Sn Insert-Tab: CuSn0.15 / Ag		⑤

temperature rise

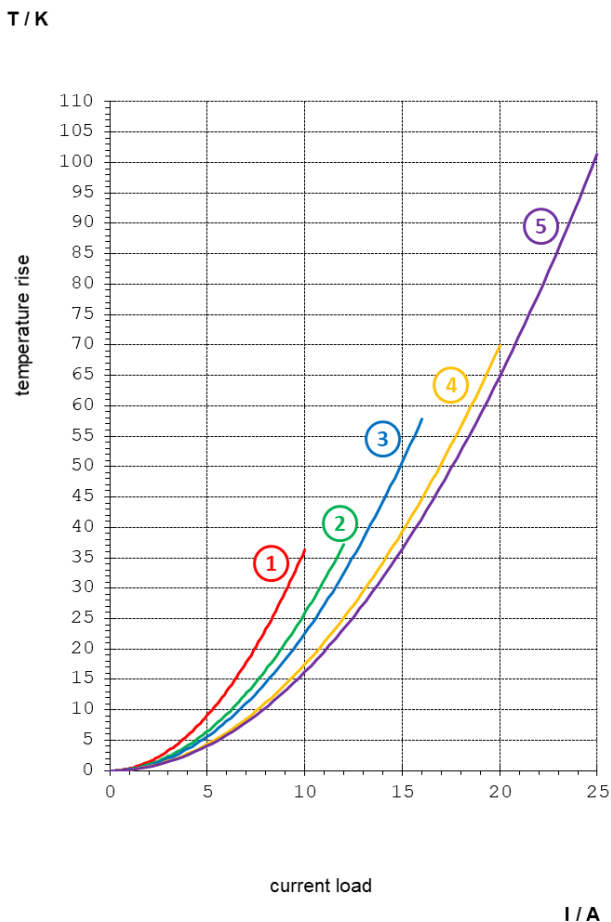

derating curve

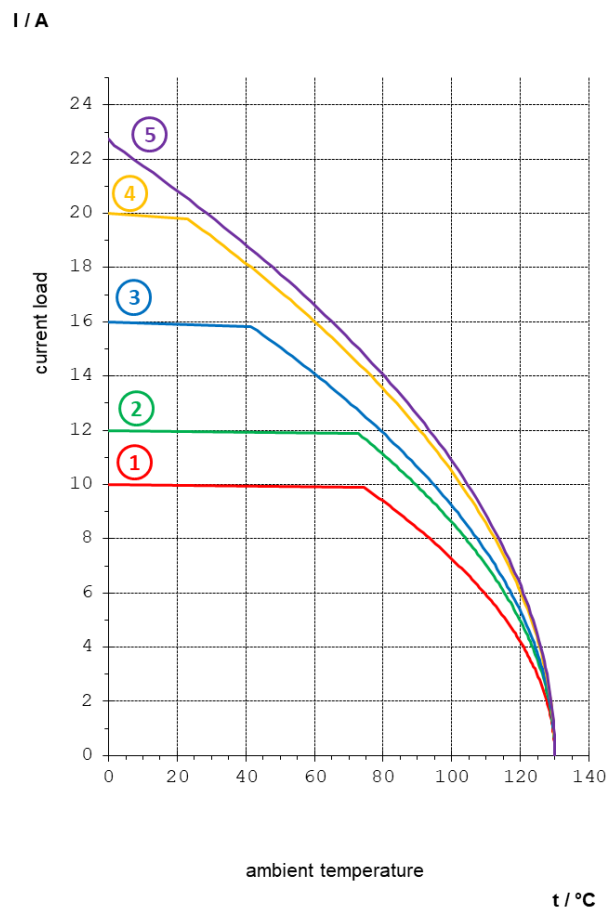

*) The limit temperatures as well as the maximum current carrying capacity of the used wires have to be considered /
 Die Grenztemperaturen sowie die maximale Stromtragfähigkeit der verwendeten Leitungen sind zu berücksichtigen

Temperature rise / derating free in air Stromerwärmung / Derating frei in Luft		MCON 1.2 CB, 0.35 – 1.50 mm ²		
Wire/Leitung: *)	MCON 1.2 CB Material Body: CuSn0.15 / SnAg Insert: CuNiSi	Tab / Flachstecker 1.2 mm	Note / Bemerkung	Graph
0.35 mm ² FLR	1534594-3 / Ag	0-1718348-3 Material Body: CuSn0.15/0.20 / Sn Insert-Tab: CuSn0.15 / Ag	For 150°C applications partly derived from 130°C appli- cations / Für 150°C Anwendungen teilweise von 130°C Anwendungen abgeleitet	①
0.50 mm ² FLR	1670144-3 / Ag	0-1718350-3 Material Body: CuSn0.15/0.20 / Sn Insert-Tab: CuSn0.15 / Ag		②
0.75 mm ² FLR	1670144-3 / Ag	0-1718350-3 Material Body: CuSn0.15/0.20 / Sn Insert-Tab: CuSn0.15 / Ag		③
1.00 mm ² FLR	1452503-3 / Ag	0-2177610-3 Material Body: CuSn4 / Sn Insert-Tab: CuSn0.15 / Ag		④
1.50 mm ² FLR	1452503-3 / Ag	0-2177610-3 Material Body: CuSn4 / Sn Insert-Tab: CuSn0.15 / Ag		⑤

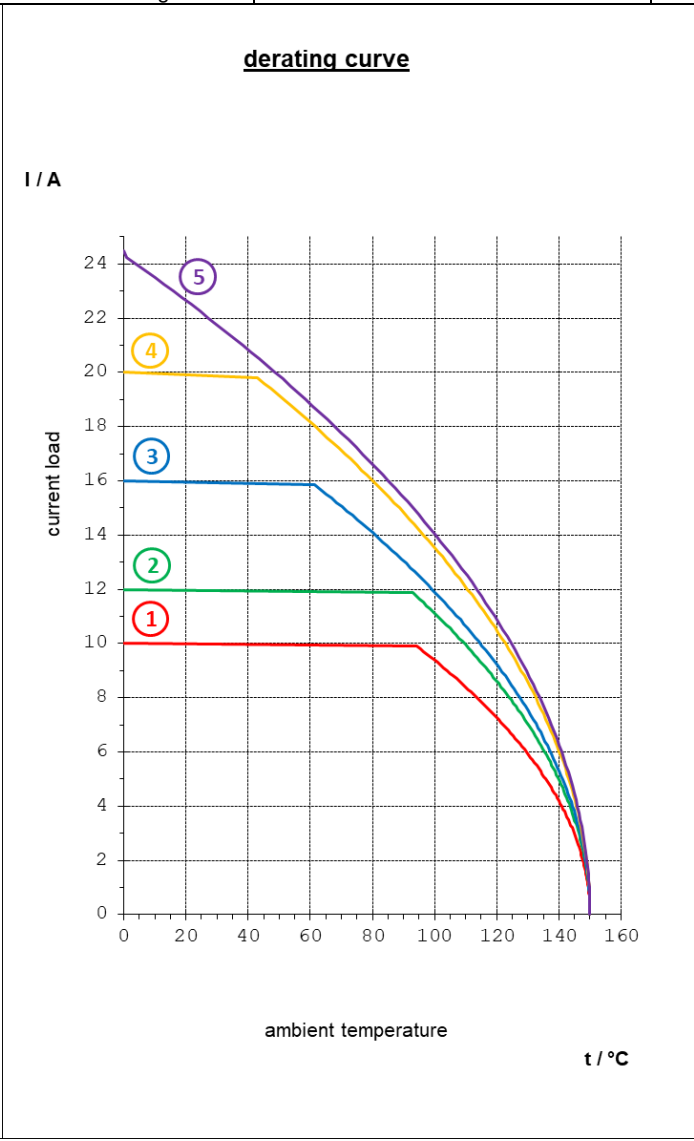
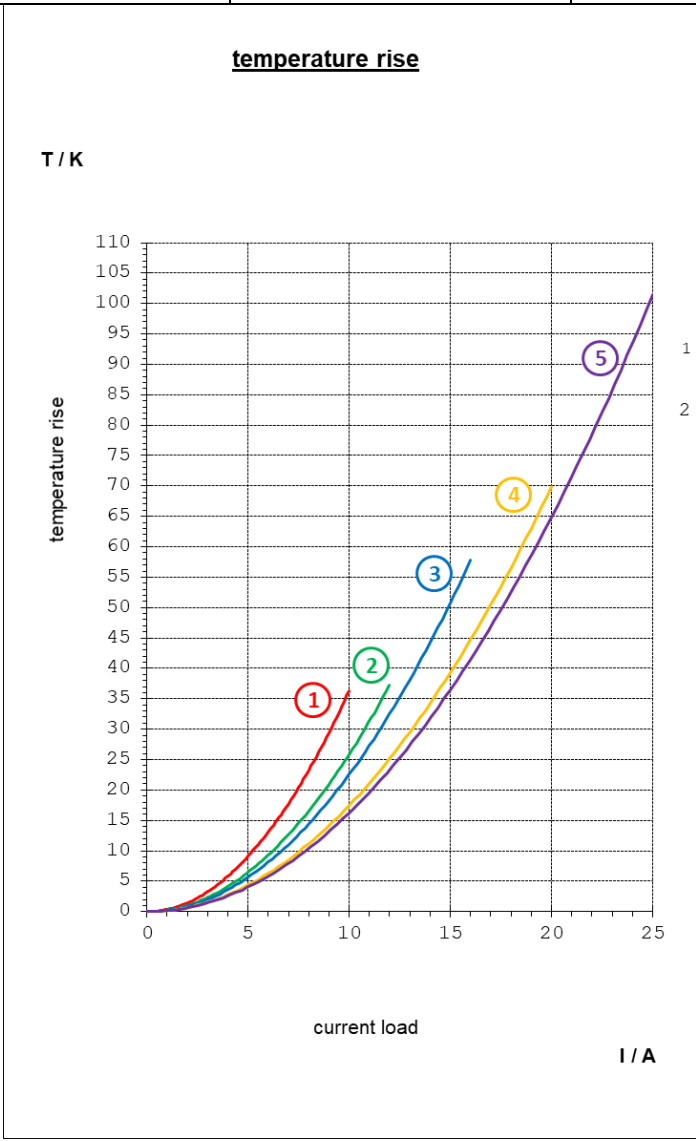

*) The limit temperatures as well as the maximum current carrying capacity of the used wires have to be considered /
 Die Grenztemperaturen sowie die maximale Stromtragfähigkeit der verwendeten Leitungen sind zu berücksichtigen

Temperature rise / derating free in air Stromerwärmung / Derating frei in Luft		MCON 1.2 LL, 0.13 – 0.22 mm ²		
Wire/Leitung: *)	MCON 1.2 LL Material Body: CuSn4 / Sn Insert: CuNiSi	Tab / Flachstecker 1.2 mm	Note / Bemerkung	Graph
0.13 mm² FLR Type B Reinforced wire acc. to LV 112-4 Zugverstärkte Leitung nach LV 112-4	0-2141861-1 / SnAg 0-2141861-2 / Au	a) 0-2141864-1 b) 0-2141864-2 Material Body: CuNiSi / Sn a) Insert-Tab: CuSn0.15 / Sn b) Insert Tab: CuSn0.15/Au	For 130°C curve For 150°C curve	a b 1
0.17 mm² FLR Type B Reinforced wire acc. to LV 112-4 Zugverstärkte Leitung nach LV 112-4	0-2141861-1 / SnAg 0-2141970-2 / Au	a) 0-2141864-1 b) 0-2141868-2 Material Body: CuNiSi / Sn a) Insert-Tab: CuSn0.15 / Sn b) Insert Tab: CuSn0.15/Au	For 130°C curve For 150°C curve	a b 2
0.22 mm² ACW Wire for Tabs soldered Leitung an Flachstecker angelötet	0-2141970-3 / Ag	0-1418758-3 Material Body: CuNiSi / Sn Insert-Tab: CuSn0.15 / Ag	130°C derived from 150°C curve For 150°C curve	a b 3

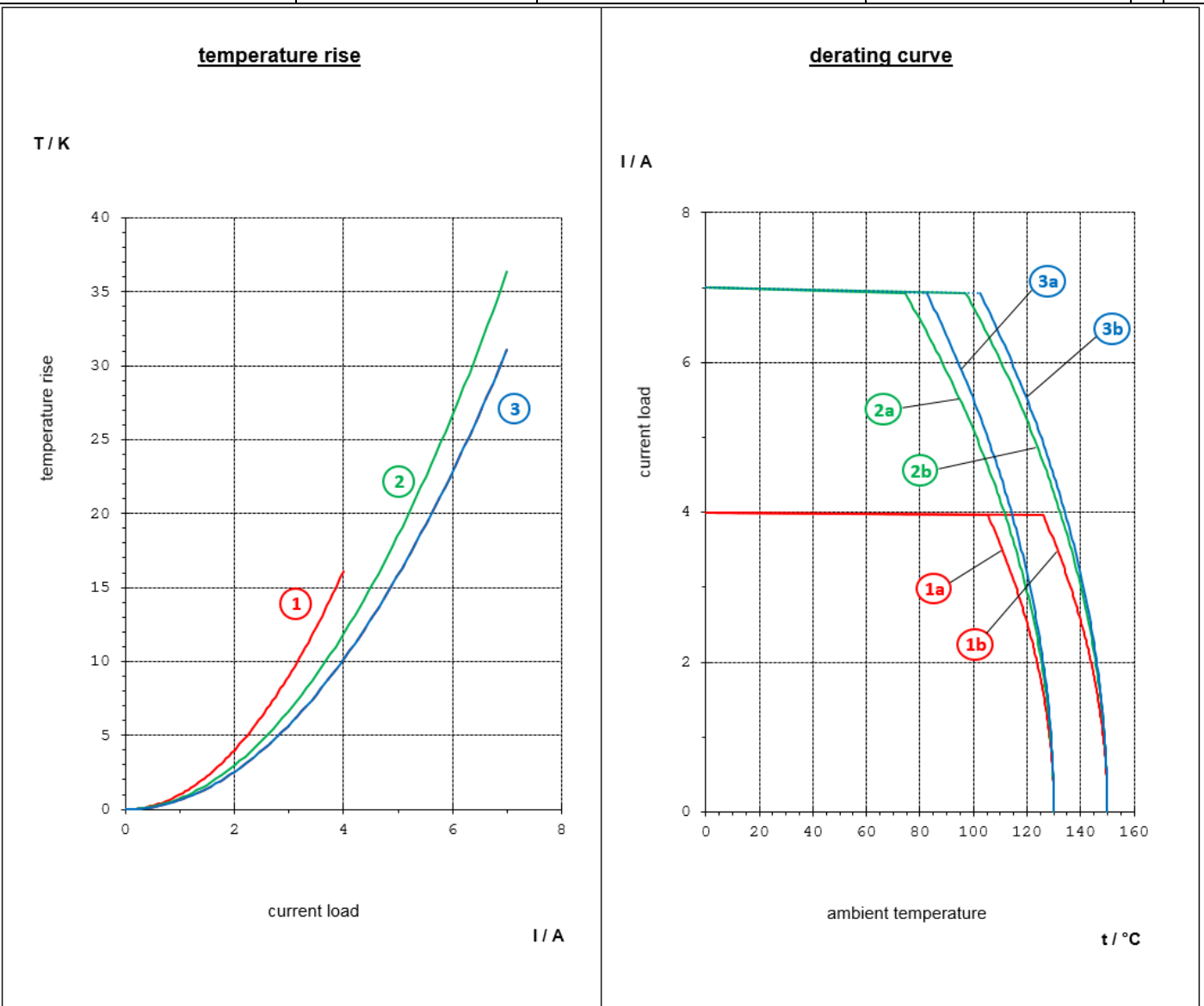

*) The limit temperatures as well as the maximum current carrying capacity of the used wires have to be considered /
 Die Grenztemperaturen sowie die maximale Stromtragfähigkeit der verwendeten Leitungen sind zu berücksichtigen

Temperature rise / derating free in air Stromerwärmung / Derating frei in Luft		MCON 1.2 LL, 0.35 – 1.50 mm ²		
Wire/Leitung: *)	MCON 1.2 LL Material Body: CuSn4 / Sn Insert: CuNiSi	Tab / Flachstecker 1.2 mm	Note / Bemerkung	Graph
0.35 mm ² FLR Typ A	7-1452653-1 / SnAg	5-1418758-1 Material Body: CuNiSi / Sn Insert-Tab: CuSn0.15 / Sn	For 130°C applications / Für 130°C Anwendungen	1
0.50 mm ² FLR Typ B	7-1452656-1 / SnAg	0-1718350-1 Material Body: CuNiSi / Sn Insert-Tab: CuSn0.15 / Sn		2
0.75 mm ² FLR Typ B	7-1452656-1 / SnAg	0-1718350-1 Material Body: CuNiSi / Sn Insert-Tab: CuSn0.15 / Sn		3
1.00 mm ² FLR Typ B	7-1452659-1 / SnAg	0-1418762-1 Material Body: CuNiSi / Sn Insert-Tab: CuSn0.15 / Sn		4
1.50 mm ² FLR Typ B	7-1452659-1 / SnAg	0-1418762-1 Material Body: CuNiSi / Sn Insert-Tab: CuSn0.15 / Sn		5

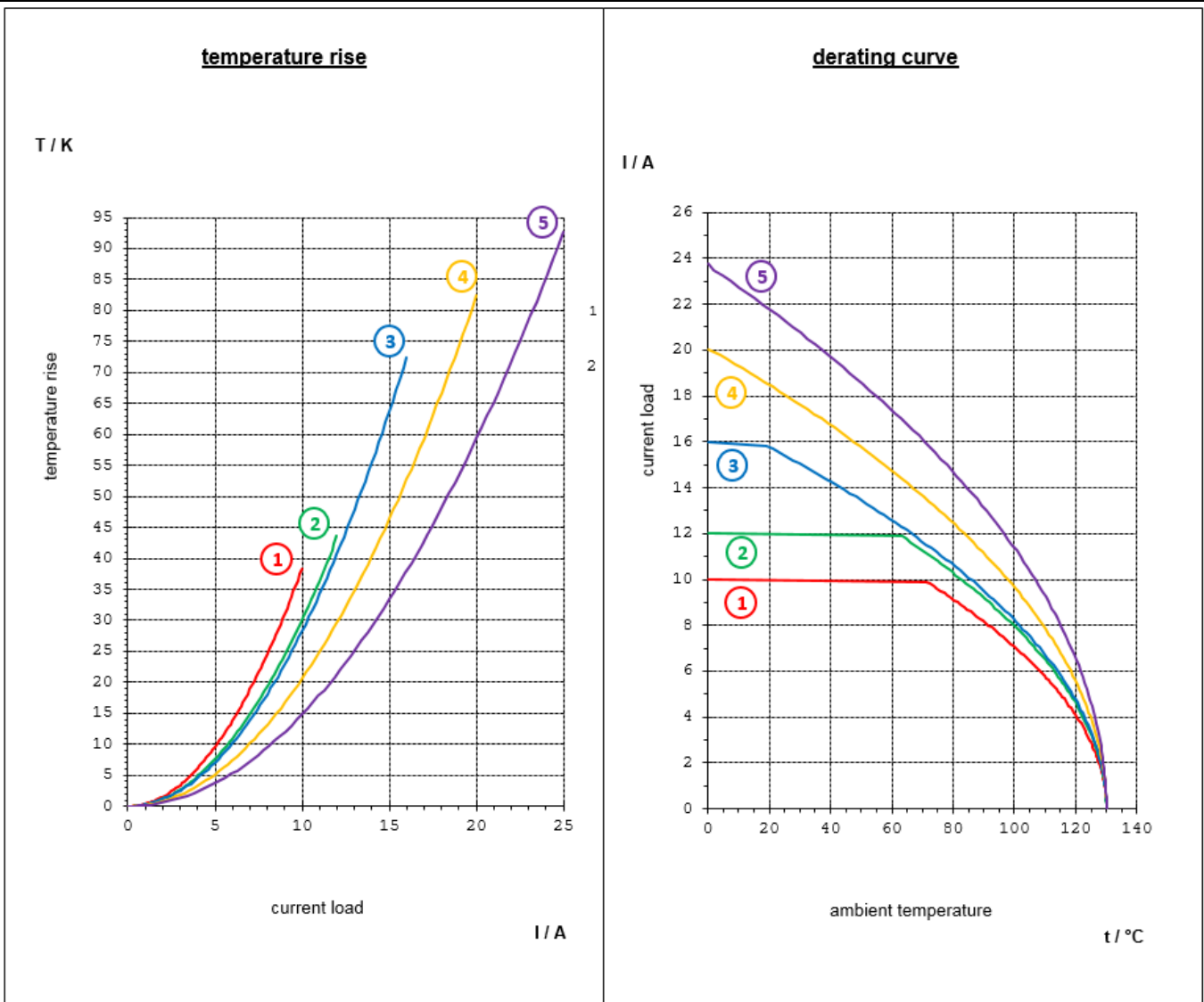

*) The limit temperatures as well as the maximum current carrying capacity of the used wires have to be considered /
 Die Grenztemperaturen sowie die maximale Stromtragfähigkeit der verwendeten Leitungen sind zu berücksichtigen

Temperature rise / derating free in air Stromerwärmung / Derating frei in Luft		MCON 1.2 LL, 0.35 – 1.50 mm ²		
Wire/Leitung: *)	MCON 1.2 LL Material Body: CuSn4 / Sn Insert: CuNiSi	Tab / Flachstecker 1.2 mm	Note / Bemerkung	Graph
0.35 mm ² FLR Typ A	7-1452653-1 / SnAg	5-1418758-3 Material Body: CuNiSi / Sn Insert-Tab: CuSn0.15 / Ag	For 150°C applications Für 150°C Anwendungen	1
0.50 mm ² FLR Typ B	7-1452656-1 / SnAg	0-1718350-3 Material Body: CuNiSi / Sn Insert-Tab: CuSn0.15 / Ag		2
0.75 mm ² FLR Typ B	7-1452656-1 / SnAg	0-1718350-3 Material Body: CuNiSi / Sn Insert-Tab: CuSn0.15 / Ag		3
1.00 mm ² FLR Typ B	7-1452659-1 / SnAg	0-1418762-3 Material Body: CuNiSi / Sn Insert-Tab: CuSn0.15 / Ag		4
1.50 mm ² FLR Typ B	7-1452659-1 / SnAg	0-1418762-3 Material Body: CuNiSi / Sn Insert-Tab: CuSn0.15 / Ag		5

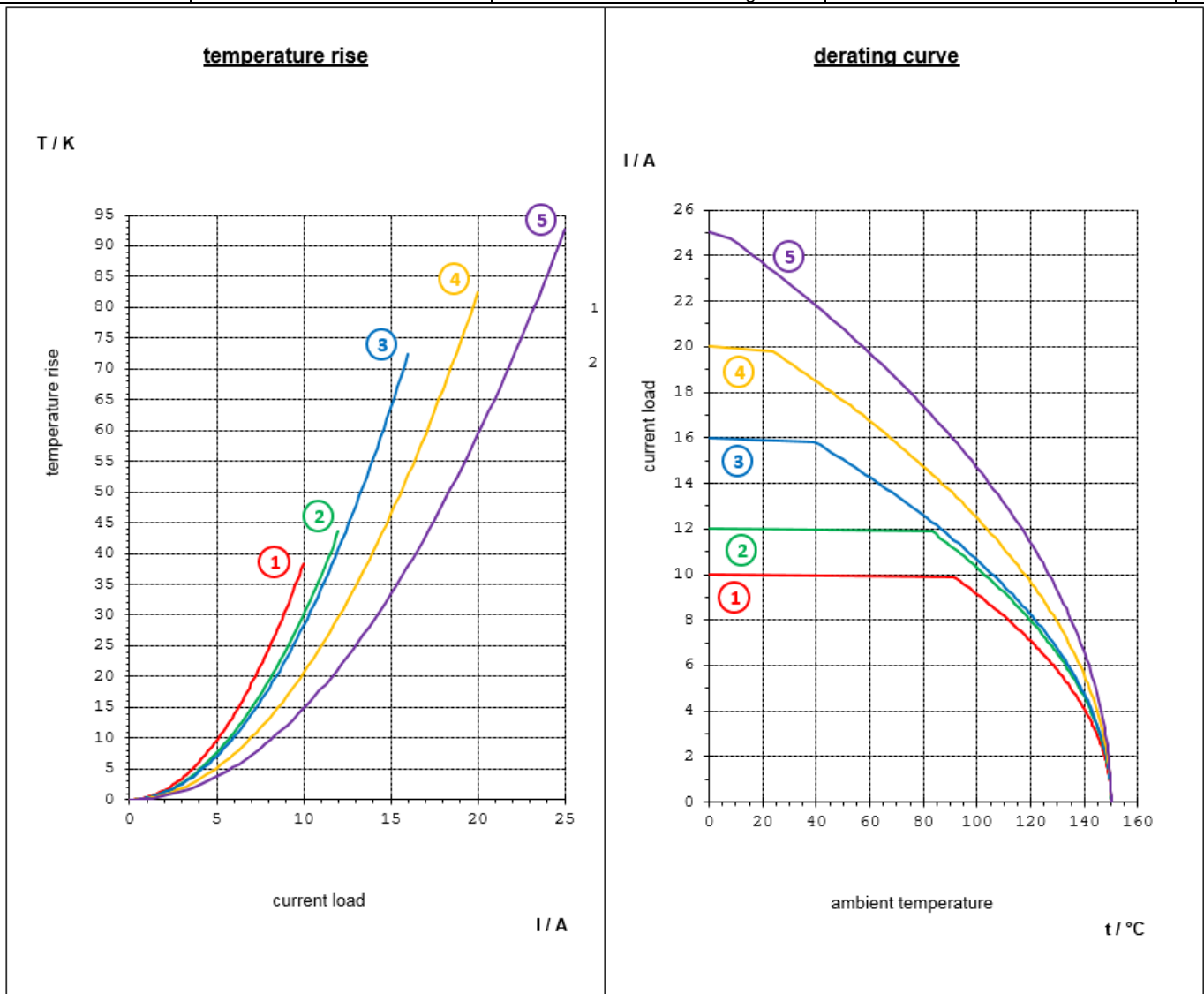

*) The limit temperatures as well as the maximum current carrying capacity of the used wires have to be considered /
 Die Grenztemperaturen sowie die maximale Stromtragfähigkeit der verwendeten Leitungen sind zu berücksichtigen

Temperature rise / derating free in air Stromerwärmung / Derating frei in Luft		MCON 1.2 LL, 0.35 – 1.50 mm ²		
Wire/Leitung: *)	MCON 1.2 LL Material Body: CuSn4 / Sn Insert: CuNiSi	Tab / Flachstecker 1.2 mm	Note / Bemerkung	Graph
0.35 mm ² FLR Typ A	7-1452653-3 / Ag	5-1418758-3 Material Body: CuNiSi / Sn Insert-Tab: CuSn0.15 / Ag	For 170°C applications derived from 150°C applications / Für 170°C Anwendungen von 150°C Anwendungen abgeleitet	1
0.50 mm ² FLR Typ B	7-1452656-3 / Ag	0-1718350-3 Material Body: CuNiSi / Sn Insert-Tab: CuSn0.15 / Ag		2
0.75 mm ² FLR Typ B	7-1452656-3 / Ag	0-1718350-3 Material Body: CuNiSi / Sn Insert-Tab: CuSn0.15 / Ag		3
1.00 mm ² FLR Typ B	7-1452659-3 / Ag	0-1418762-3 Material Body: CuNiSi / Sn Insert-Tab: CuSn0.15 / Ag		4
1.50 mm ² FLR Typ B	7-1452659-3 / Ag	0-1418762-3 Material Body: CuNiSi / Sn Insert-Tab: CuSn0.15 / Ag		5

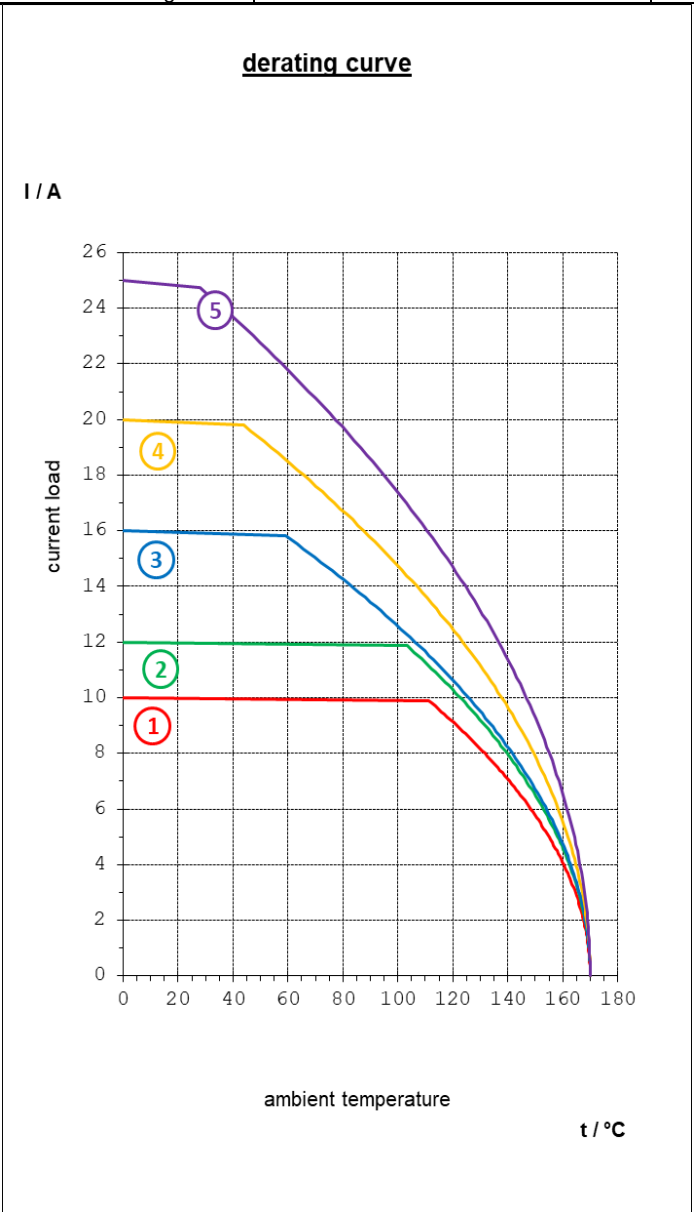
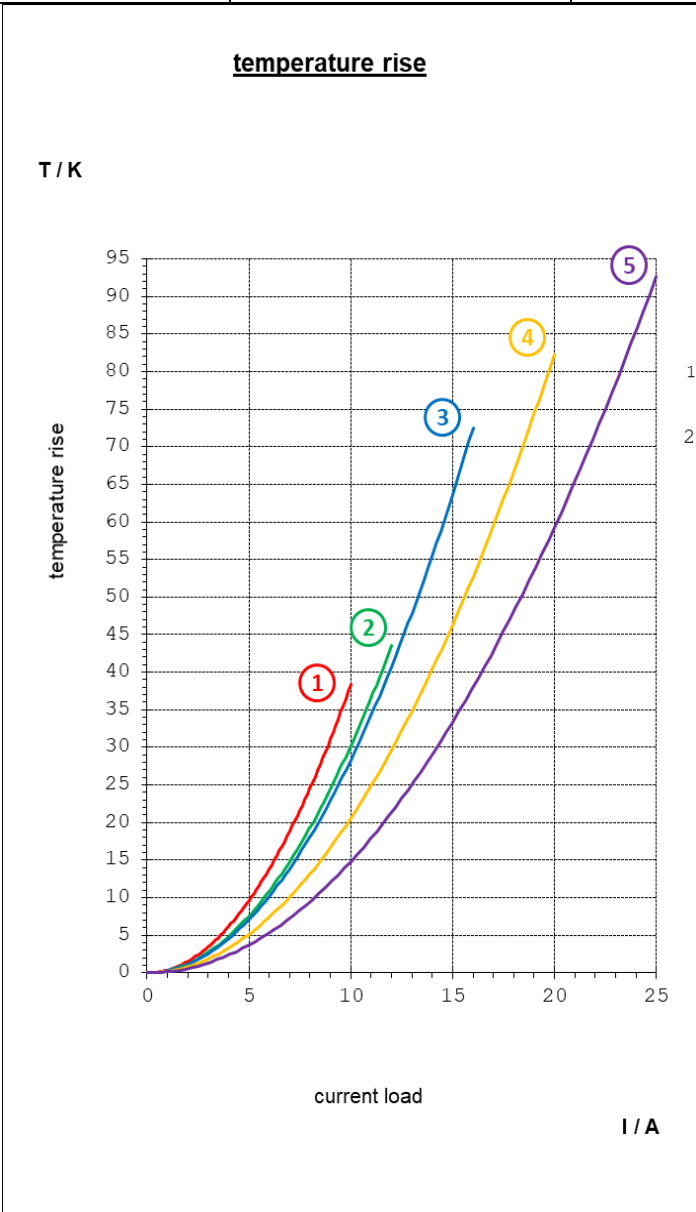

*) The limit temperatures as well as the maximum current carrying capacity of the used wires have to be considered /
 Die Grenztemperaturen sowie die maximale Stromtragfähigkeit der verwendeten Leitungen sind zu berücksichtigen

4.2. Effect of housing on derating

4.2. Gehäuseeinfluss auf das Derating

Effect of housing on derating / Gehäuseeinfluss auf das Derating		MCON 1.2 LL, 0.35 – 1.50 mm ²		
Wire/Leitung: *)	MCON 1.2 LL Material Body: CuSn0.15 / Sn Insert: CuNiSi	Tab / Flachstecker 1.2 mm	Receptacle housing / Buchsengehäuse	Graph
0.35 mm ² FLR	7-1452665-3 / Ag	0-1718758-3 Material Body: CuNiSi / Sn Insert-Tab: CuSn0.15 / Ag	1-1718645-2 (4 pol, sealed) 3 cavities loaded / 3 Kammern belastet Material: PA66 GF30	①
0.50 mm ² FLR	7-1452668-3 / Ag	11 pol. Header mit angelöteten FLR-Leitungen / 11 pos. Header with soldered FLR wires	0-2282330-1 (11 pol, mixed, sealed) 8 cavities loaded / 8 Kammern belastet Material: PA66 GF30	②
0.75 mm ² FLR	7-1452668-1 / SnAg	0-1718760-1 Material Body: CuNiSi / Sn Insert-Tab: CuSn0.15 / Sn	1-2141397-1 (6 pol, sealed) 6 cavities loaded / 6 Kammern belastet Material: PA66 GF30	③
1.00 mm ² FLR	7-1452671-3 / Ag	11 pol. Header mit angelöteten FLR-Leitungen / 11 pos. Header with soldered FLR wires	0-2282330-1 (11 pol, mixed, sealed) 1 cavity loaded / 1 Kammer belastet Material: PA66 GF30	④.1
1.00 mm ² FLR	7-1452671-3 / Ag	11 pol. Header mit angelöteten FLR-Leitungen / 11 pos. Header with soldered FLR wires	0-2282330-1 (11 pol, mixed, sealed) 8 cavities loaded / 8 Kammern belastet Material: PA66 GF30	④.2
1.50 mm ² FLR	7-1452671-3 / Ag	0-1718762-3 Material Body: CuNiSi / Sn Insert-Tab: CuSn0.15 / Ag	1-2141397-1 (6 pol, sealed) 6 cavities loaded / 6 Kammern belastet Material: PA66 GF30	⑤

temperature rise

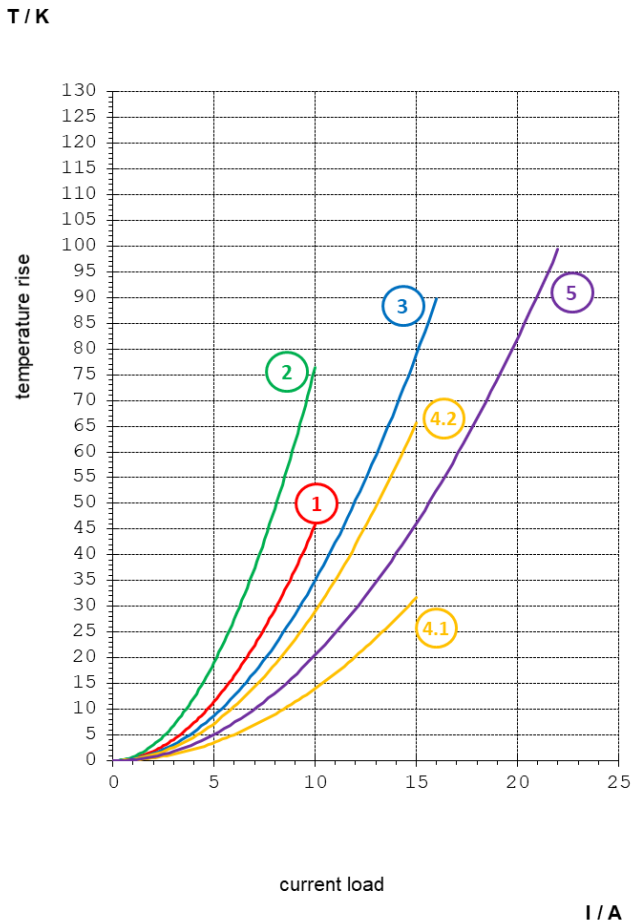

derating curve

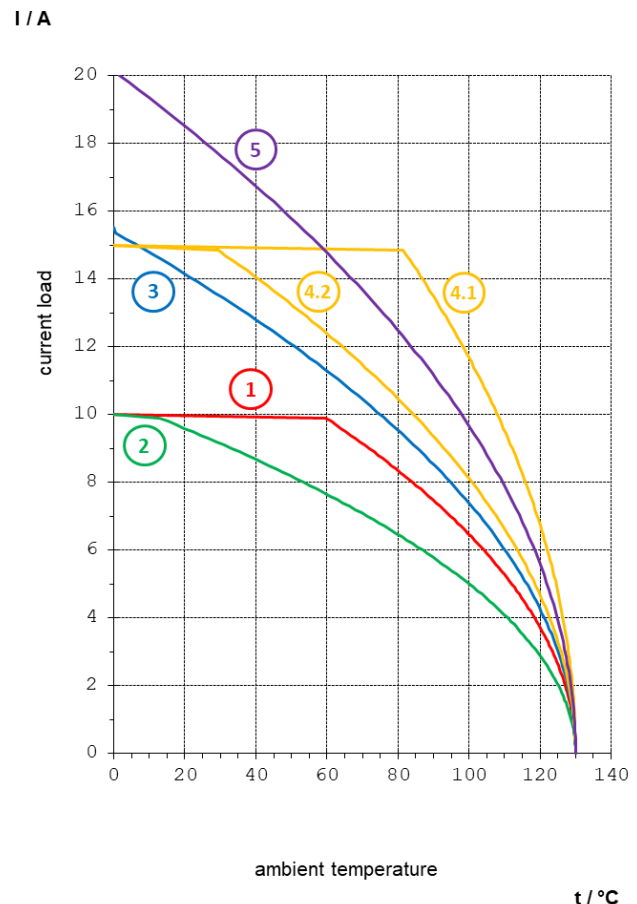

*) The limit temperatures as well as the maximum current carrying capacity of the used wires have to be considered /
 Die Grenztemperaturen sowie die maximale Stromtragfähigkeit der verwendeten Leitungen sind zu berücksichtigen

4.3. Short term current overload

4.4. Thermische Zeitkonstante

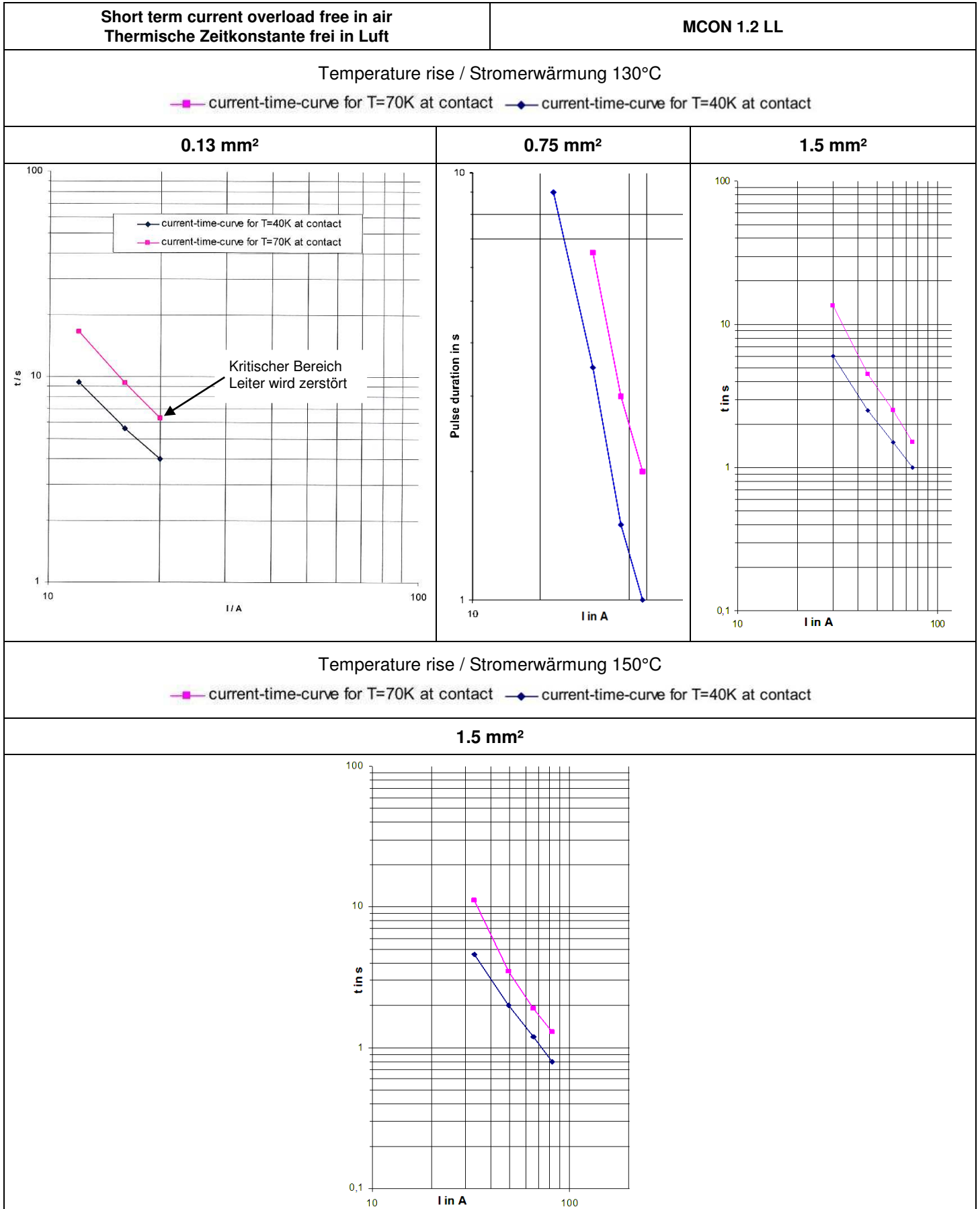



<u>LTR</u>	<u>REVISION RECORD</u>	<u>DWN</u>	<u>CHK</u>	<u>APP</u>	<u>DATE</u>
E	Korrektur der Formulierung bei PG11	C.Deissler	M. Brunner	M. Jost	22.01.20
D	Herausnehmen LL-CuSn0.15 Varianten, Anpassungen bei PG8 und PG11, Hinzufügen von PG21, Anpassung Derating-Kurven, div. red. Änderungen, etc.	C.Deissler	M. Brunner	M. Jost	18.12.19
C	Berücksichtigung LL-CuSn4 Varianten, Anpassung Leistungsmerkmale, div. red. Änderungen, etc.	J. Kurfiss	C. Göppel	M. Jost	06.12.16
B		R Meier	W. Müller	V. Seipel	18.06.10
A	Veröffentlichung	R. Meier	U. Münk		15.09.06