

REVISIONS				
P	LTR	DESCRIPTION	DATE	OWN
E2		REVISED PER ECO-17-009556	03JUL2017	RS

勝特力電材超市-龍山店 886-3-5773766
 勝特力電材超市-光復店 886-3-5729570
 勝特力电子(上海) 86-21-34970699
 勝特力电子(深圳) 86-755-83298787
<http://www.100y.com.tw>

- BULK PACKAGED, UNASSEMBLED.
- APPROVAL AGENCY LOGO LOCATED APPROXIMATELY AS SHOWN.
- AMP LOGO LOCATED THIS SURFACE.
- CIRCUIT NUMBER ONE IDENTIFICATION RIB AND CIRCUIT IDENTIFICATION NUMBERS ARE EACH LOCATED ADJACENT TO THE APPROPRIATE CIRCUIT CAVITIES.
- NEW MOLD CONSTRUCTION PROVIDES MATERIAL REDUCTION CORING AT BASE OF SILOS WITH NO CORING AS OPTIONAL.
- DIMENSIONS SHOWN REPRESENT PRODUCT IN DRY, AS MOLDED CONDITION. ADDITIONAL 2% GROWTH DUE TO SUBSEQUENT MOISTURE ABSORPTION MAY OCCUR AND SHOULD BE ACCOUNTED FOR

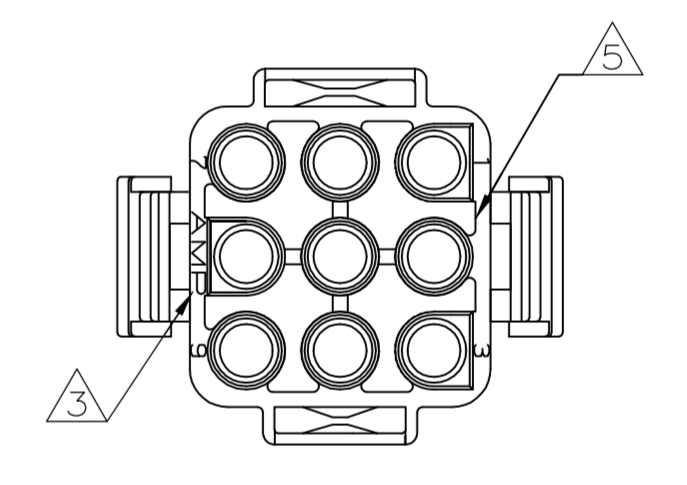
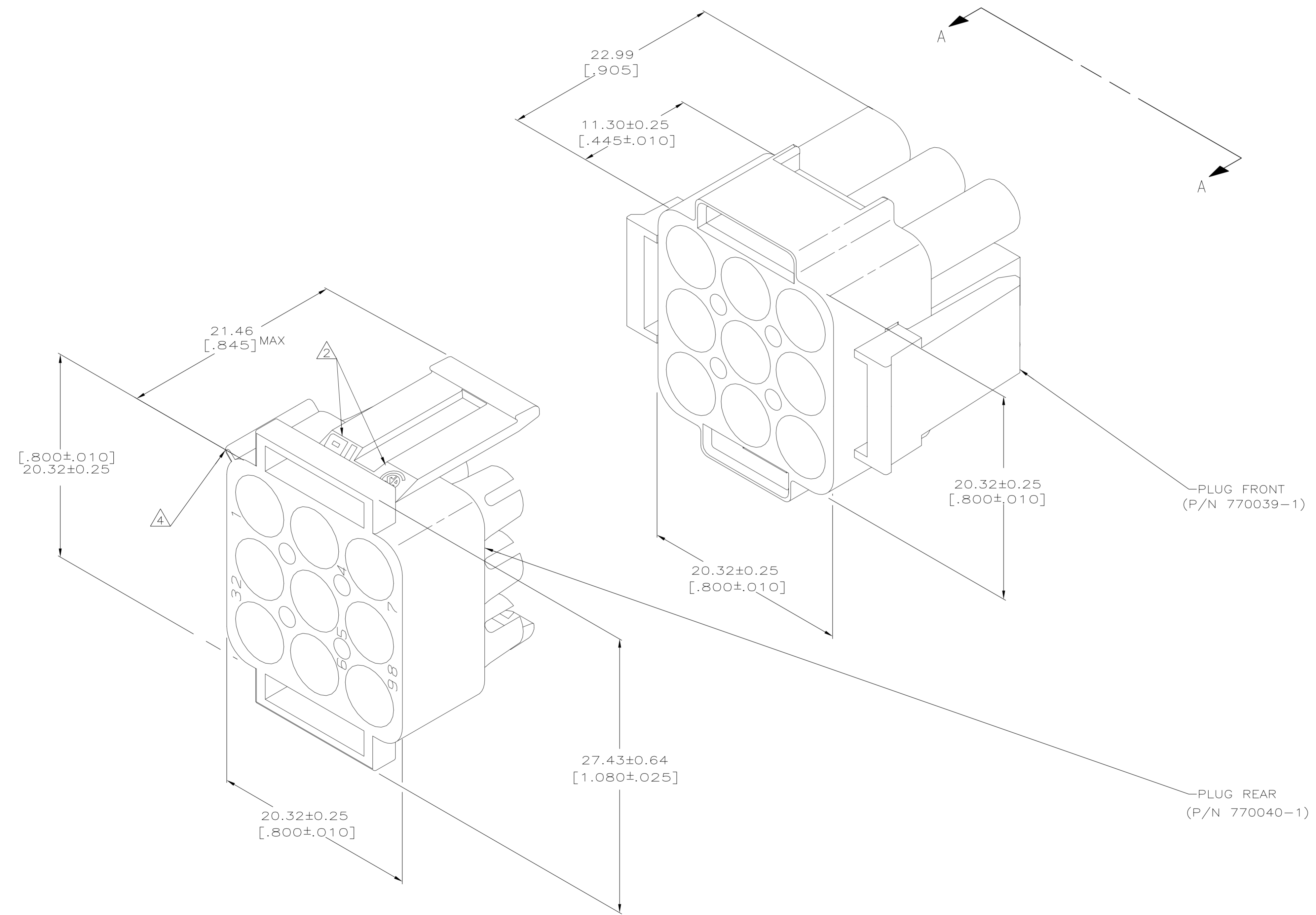

VIEW A-A
SCALE 2:1

770021-1
PART NUMBER

METRIC

THIS DRAWING IS A CONTROLLED DOCUMENT.		DWN K. SALMON 1-22-92	STE TE Connectivity	
DIMENSIONS: INCHES		CHK R. SWING 1-22-92	NAME PLUG HOUSING KIT, 9 CIRCUIT, UNIVERSAL MATE-N-LOK™	
TOLERANCES UNLESS OTHERWISE SPECIFIED:		APVD M. TRULL 1-22-92	PRODUCT SPEC	
0. PLC	± -	APPLICATION SPEC	RESTRICTED TO	
1. PLC	± -	SIZE	CAGE CODE	DRAWING NO
2. PLC	± -	WEIGHT	0.000000	A1 00779
3. PLC	± 0.13 [.005]	CUSTOMER DRAWING	SCALE	5:1
4. PLC	± -	SHEET	1	OF 1
ANGLES	± -	REV	E2	
MATERIAL NYLON,UL94V-0,	FINISH -	DRAWING NO 770021		



NOTE

All numerical values are in metric units [with U.S. customary units in brackets]. Dimensions are in millimeters [and inches]. Unless otherwise specified, dimensions have a tolerance of ± 0.13 [$\pm .005$] and angles have a tolerance of $\pm 2^\circ$. Figures and illustrations are for identification only and are not drawn to scale.

1. INTRODUCTION

This specification covers the requirements for application of Universal MATE-N-LOK* II housings and the contacts used with the housings. The housings are available in 2- through 15-circuit versions and are intended for use in wire-to-wire panel-mounted applications.

When corresponding with personnel, use the terminology provided in this specification to facilitate your inquiries for information. Basic terms and features of this product are provided in Figure 1.

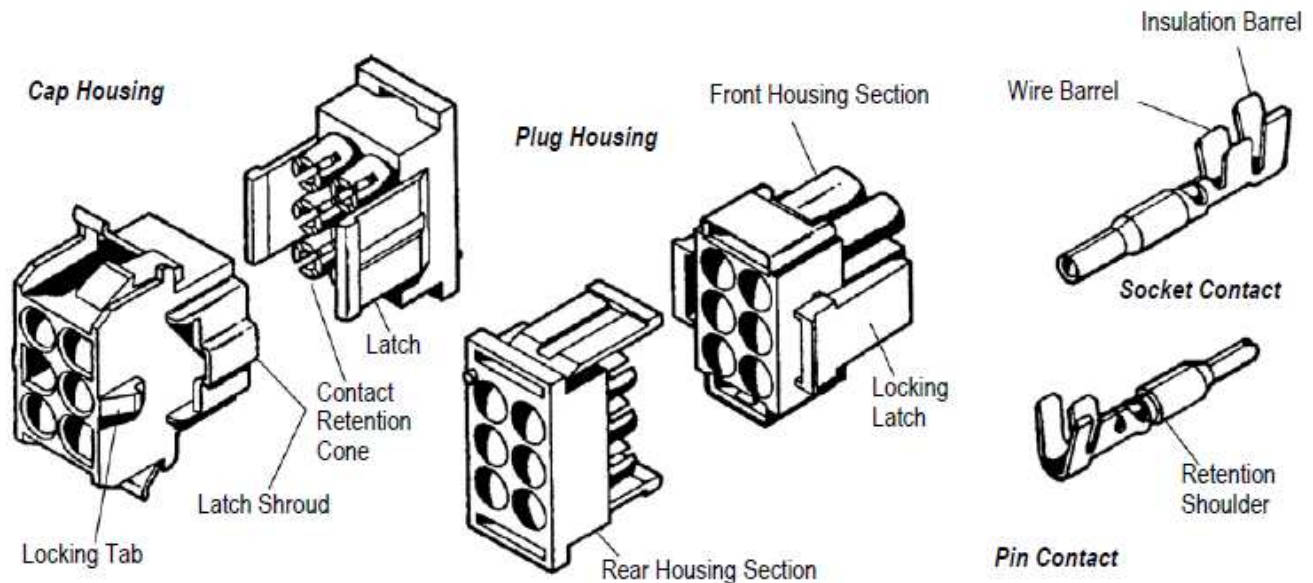

Figure 1

2. REFERENCE MATERIAL

2.1. Revision Summary

This paragraph is reserved for a revision summary covering the most recent additions and changes made to this specification which include the following:

- Added Paragraph 3.4.D and Figure 4
- Updated document to corporate logo and template requirements, adding Paragraphs 3.1 and 3.2.

2.2. Customer Assistance

Reference Product Base Part Number 770020 and Product Code 1408 are representative of Universal MATE-N-LOK* II product line. Use of these numbers will identify the product line and help you to obtain product and tooling information when visiting www.te.com or calling the number at the bottom of page 1.

2.3. Drawings

Customer drawings for product part numbers are available from www.te.com. Information contained in the customer drawing takes priority.

2.4. Specifications

Product Specification [108-1090](#) provides product performance and test results.

2.5. Instructional Material

Instruction material for automatic and hand application tooling is shipped with the appropriate tooling. Refer to Figure 2 for referenced documents.

3. REQUIREMENTS

3.1. Safety

Do not stack product shipping containers so high that the containers buckle or deform.

3.2. Storage

A. Ultraviolet Light

Prolonged exposure to ultraviolet light may deteriorate the chemical composition used in the product material.

B. Shelf Life

The product should remain in the shipping containers until ready for use to prevent deformation to components. The product should be used on a first in, first out basis to avoid storage contamination that could adversely affect performance.

C. Chemical Exposure

Do not store product near any chemical listed below as they may cause stress corrosion cracking in the material.

Alkalies	Ammonia	Citrates	Phosphates	Citrates	Sulfur Compounds
Amines	Carbonates	Nitrites	Sulfur Nitrites		Tartrates

3.3. Wire

A. Wire Selection

The contacts will accept wires ranging in size from 10 to 30 AWG. Wire insulation diameter shall have minimum and maximum dimensions according to the wire sizes indicated in

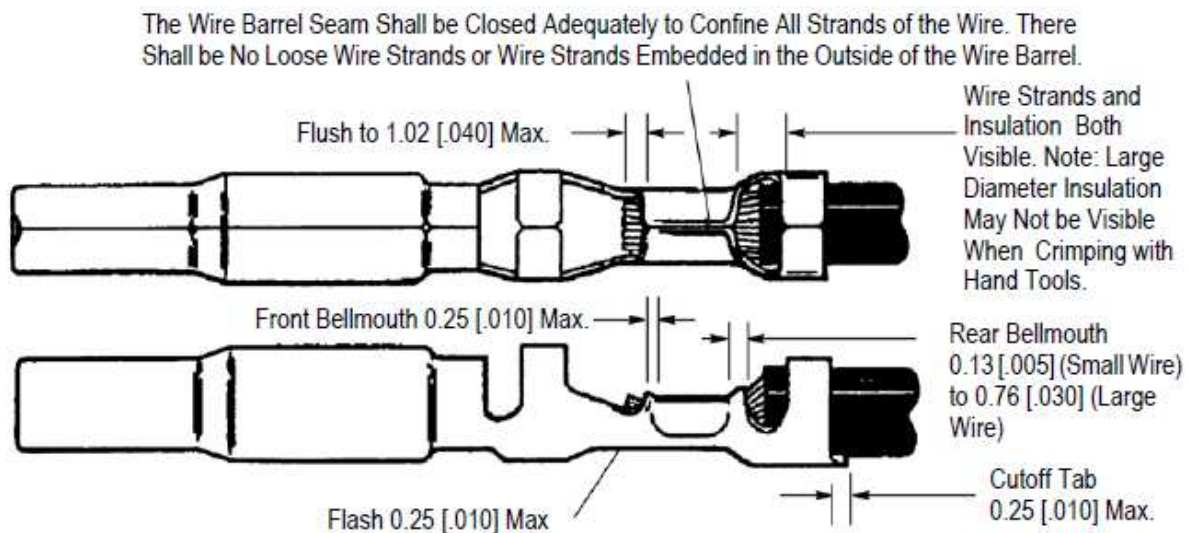

Figure 2 (continued)

WIRE			WIRE BARREL		INSULATION BARREL CRIMP WIDTH	APPLICATOR PART NUMBER●
SIZE (AWG)	INSULATION DIAMETER RANGE	STRIP LENGTH ±0.38 [.015]	CRIMP HEIGHT ±0.05 [.002]	CRIMP WIDTH		
30	0.81 – 1.45 [.032 – .057]	3.58 [.141]	0.71 [.028]	1.40 [.055]	2.29 [.090]	567252-1 567252-2
28			0.71 [.028]			
26			0.76 [.030]			
24	1.02 – 2.54 [.040 – .100]	4.37 [.172]	0.97 [.038]	1.78 [.070]	2.54 [.100]	567214-1 567214-2
22			1.02 [.040]			
20			1.09 [.043]			
18			1.22 [.048]			
20	1.52 – 3.30 [.060 – .130]	4.37 [.172]	1.19 [.047]	2.29 [.090]	3.30 [.130]	567213-1 567213-2
18			1.32 [.052]			
16			1.50 [.059]			
14			1.75 [.069]			
20	3.30 – 5.08 [.130 – .200]	4.37 [.172]	1.19 [.047]	2.29 [.090]	5.08 [.200]	567212-1 567212-2
18			1.32 [.052]			
16			1.50 [.059]			
14			1.75 [.069]			
12	5.08 [.200] Max.	6.76 [.266]	1.80 [.071]	3.56 [.140]	–	567211-1 567211-2
10			2.18 [.086]			
30	0.81 – 1.45 [.032 – .057]	4.45 – 5.08 [.175 – .200]	0.71 [.028]	1.40 [.055]	2.29 [.090]	58439-1 (408-9591)
28			0.71 [.028]			
26			0.71 [.028]			
24	1.27† – 2.54 [.050† – .100]	4.45 – 5.08 [.175 – .200]	1.02 [.040]	1.78 [.070]	2.54 [.100]	90300-2 (408-9479)
22			1.02 [.040]			
20			1.17 [.046]			
18			1.17 [.046]			
20	1.52 – 3.30 [.060 – .130]	4.45 – 5.08 [.175 – .200]	1.27 [.050]	2.29 [.090]	3.30 [.130]	90296-2 (408-9476)
18			1.27 [.050]			
16			1.60 [.063]			
14			1.60 [.063]			
20	3.30 – 5.08 [.130 – .200]	4.45 – 5.08 [.175 – .200]	1.24 [.049]	2.29 [.090]	5.08 [.200]	90298-2 (408-9477)
18			1.24 [.049]			90299-2 (408-9478)
16			1.60 [.063]			
14			1.60 [.063]			
12	5.08 [.200] Max.	6.35 – 7.14 [.250 – .281]	2.11 [.083]	3.56 [.140]	–	69710-1†† (408-2095)
10			2.44 [.096]			

●Applicator part numbers ending in -1 are used in a “T” Terminator with automatic equipment. Applicator part numbers ending in -2 are used in the AMP-O-LECTRIC* Model “K” Machine 565435-5. Refer to instruction sheet 408-8040 for applicator information. Refer to customer manual 409-5128 for Model “K” Machine information.

†Smaller diameter insulation 1.02 to 1.27 mm [.040 to .050 in] may be inadvertently placed in wire barrel.

††Hand tool uses crimping die assembly 58380-1 for 12 AWG and 58380-2 for 10 AWG.

NOTE

AMP-O-LECTRIC Model “K” Terminating Machine 565435-5 has been superseded by the Model “G” Terminating Machine 354500-1 for new applications. For existing applications, the Model “K” can still be used.

Figure 2 (end)

B. Wire Preparation

The wire strip length shall be according to the wire sizes as indicated in Figure 2. Reasonable care shall be taken during the stripping operation to ensure the conductor is not nicked, scraped, or cut.

3.4. Crimped Contacts

A. Contact Crimping

Contacts shall be crimped in accordance with the material packaged with the tooling. Refer to the tables in Figure 2.

B. Inspection

Inspect crimped contacts for conditions shown in Figure 2.

C. Alignment

The axial concentricity of the crimped wire barrel must fall into an area defined by a 4.19 mm [.165 in.] diameter circle whose center is the centerline of the contact. The axial concentricity of the crimped insulation barrel must fall into an area defined by a 5.59 mm [.220 in.] diameter circle whose center is the centerline of the contact. See Figure 3.

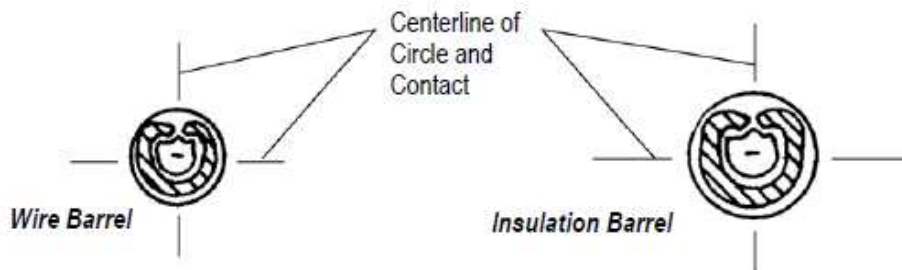

Figure 3

D. Insulation Barrel Crimp

The insulation barrel shall grip the insulation firmly and legs of the insulation support crimp barrel may deform or cut into the insulation, but must not penetrate into the conductor. This product has two styles of insulation crimp. Most common is the F-crimp. For F-crimp style, the legs of the insulation barrel touch each other, and the crimp shall comply to width provided in Figure 2. For special cases, the overlap crimp is used. The overlap allows the legs of the insulation barrel overlap itself by at least the length of one material thickness. See Figure 4.

The smallest cable within the insulation range may have a gap between the insulation and the insulation barrel leg (max. of the difference of the diameter between the smallest and largest cable), however, must touch the insulation support barrel for at least a distance equal to half its circumference. See Figure 4.



Figure 4

3.5. Housings

A connector assembly consists of a two-piece plug housing and a two-piece cap housing that accept lanceless contacts. The two-piece housings provide three-point stabilization and shock protection for the enclosed contacts. Both the plug and cap housing assemblies have individually numbered circuit identification on the back surface, plus an identification rib or button indicating the number one circuit location. The housings feature polarizing cavities on the mating faces and are intermateable with conventional Universal MATE-N-LOK* connectors and headers.

A. Assembly

Crimped pin and socket contacts shall be manually inserted in either the plug or cap rear housing section, or they may be intermixed in each rear housing to provide multiple keying combinations. Refer to Figure 5 and insert contacts and join housing sections together as follows:

1. Align and insert rear housing section into front housing section and snap into first locking stage. Pull back to ensure proper engagement and to prevent any deformation to the locking mechanism.
2. Align contact with desired circuit cavity at BACK of rear housing section. Push contact straight into cavity, forcing the retention cones open. Continue to push until the cone re-closes behind the contact retention shoulder.
3. When all necessary contacts have been inserted, complete assembly of the connector by forcing the latches into the full locked position. An additional squeeze across the latch shrouds will help the latches engage behind the locking edges. Visually inspect the latches have fully engaged behind locking edges and all contact insulation barrels are within housing. There will be little or no gap between front and rear housing sections when fully assembled.



NOTE

The front and rear housing sections cannot be fully locked together if any contact retention cone is open, indicating the contact is only partially inserted.

B. Disassembly

Damaged contacts may be replaced on an individual basis. Refer to Figure 5 and separate housing section and remove contact as follows:

1. Depress both latch heads and pull on the rear housing section to separate the housings.
2. Move the contact in a slight circular motion while pulling on the wire; this releases the retention shoulder from the housing cone.

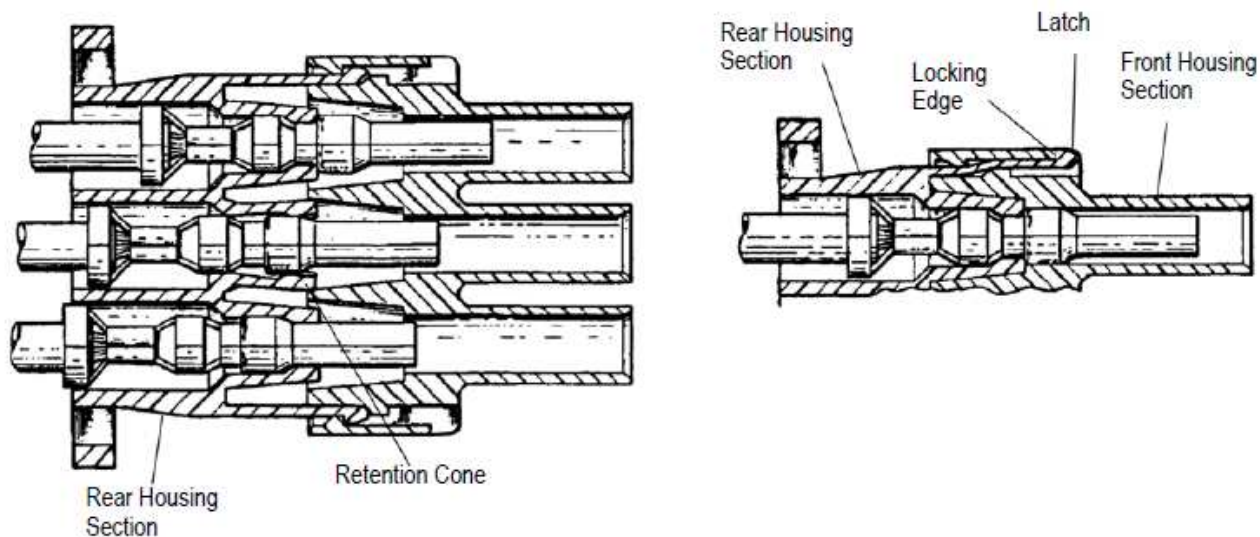

Figure 5

3.6. Strain Relief Clamps

Strain relief clamps are designed to relieve the stress of the wires on the contacts. An adjusting insert is used with smaller wire bundles. Two identical clamps are inserted into slots in the back of the plug and/or cap connector and are secured together with two No. 6 pan head self-tapping screws (not included). See Figure 6.

3.7. Keying Plugs

Keying plugs provide additional polarization for the connectors. The keying plug may be inserted into the front of the plug or the cap connector. See Figure 6.

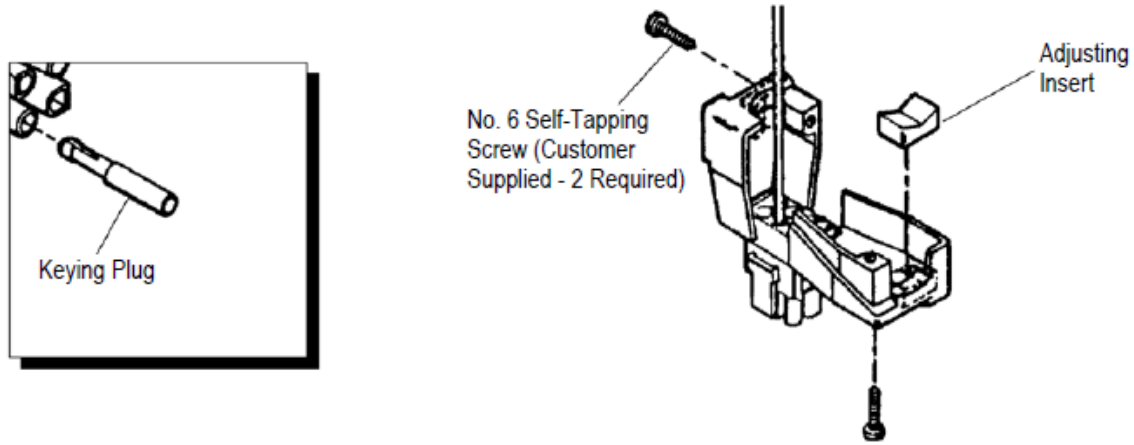

Figure 6

3.8. Panel Cutout

Cap connector panel mounting cutouts shall be as indicated in Figure 7. (No mounting hardware is required.)

The cap housing features flexible mounting tabs for insertion into the panel. Push the cap connector through the panel, in the same direction as the cutout was made, until it snaps in place.

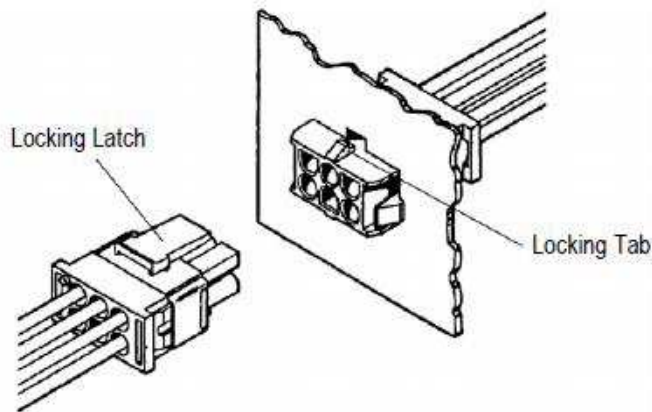
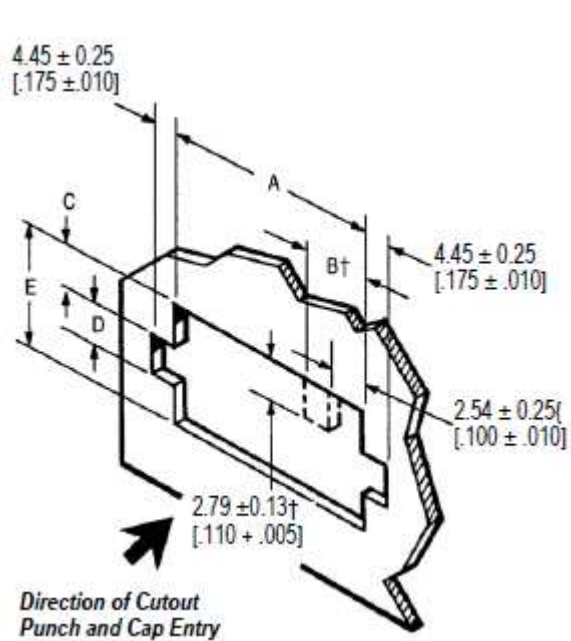

Figure 7

3.9. Connector Mating

These connectors have a positive lock feature which prevents accidental unmating. Align polarizing features as shown in Figure 8 and start plug into cap. Push connectors together until locking latches engage locking tabs.



NO. OF CIRCUIT POSITIONS	DIMENSIONS				
	A ±0.13 [.005]	B ±0.25 [.010]	C ±0.25 [.010]	D ±0.25 [.010]	E ±0.13 [.005]
2	14.35 [.565]	6.35 [.250]	2.41 [.095]	8.64 [.340]	13.46 [.530]
3	20.70 [.815]				
4	27.05 [1.065]				
6	14.35 [.565]	8.89 [.350]	6.99 [.275]	12.19 [.480]	26.16 [1.030]
9	20.70 [.815]				
12	27.05 [1.065]				
15	33.40 [1.315]	8.89 [.350]			

† Optional panel cutout dimensions for cap and panel polarization

Figure 8

4. QUALIFICATION

4.1. Underwriters Laboratories Inc. (UL)

Universal MATE-N-LOK* II connectors are recognized by Underwriters Laboratories Inc. (UL) in File E28476.

4.2. Canadian Standards Association (CSA)

Universal MATE-N-LOK* II connectors are certified to CSA International in File LR7189.

5. TOOLING

Loose piece contacts are designed to be crimped with a hand tool. Strip form contacts are designed to be crimped with a miniature applicator used in a semi-automatic or automatic machine. Tooling, applicators, and instruction material are listed in Figure 2.

6. VISUAL AID

Figure 9 shows a typical application of this product. (Socket contact shown – features illustrated also apply to pin contacts.) This illustration should be used by production personnel to ensure a correctly applied product. Applications which do not appear correct should be inspected using the information in the preceding pages of this specification and in the instructional material shipped with the product or tooling.

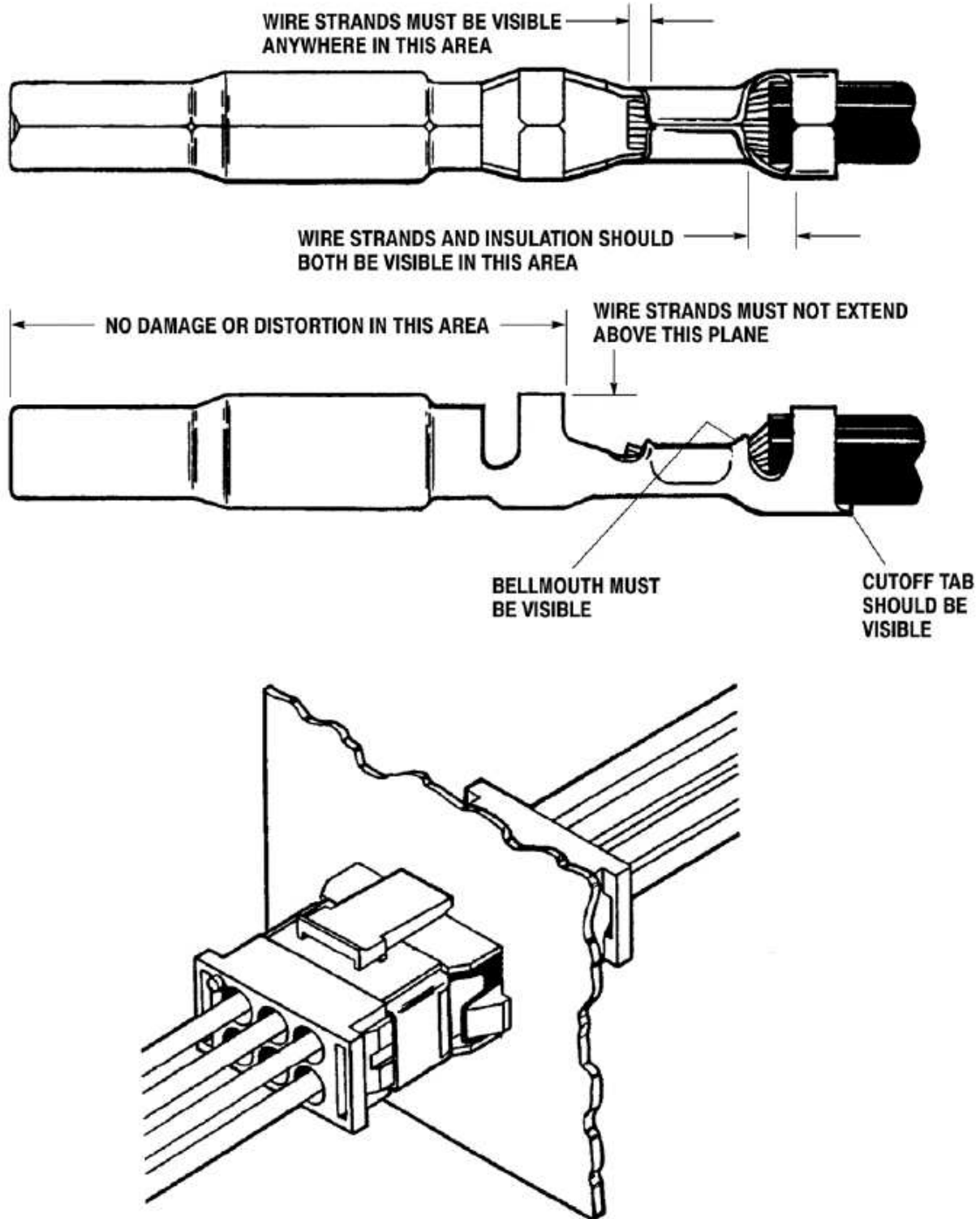

Figure 9: Visual Aid