

THIS DRAWING IS UNPUBLISHED. RELEASED FOR PUBLICATION
 © COPYRIGHT - By - ALL RIGHTS RESERVED.

LOC		DIST		REVISIONS			
P	LTR	DESCRIPTION		DATE	DWN	APVD	
CM	53	C		REVISED PER ECR-12-011218	08OCT12	KH	TM

- 1 MATERIAL: SELF LUBRICATING SILICON RUBBER
COLOR: BLUE
- 2 DIMENSIONS IN BRACKETS ARE IN INCHES.

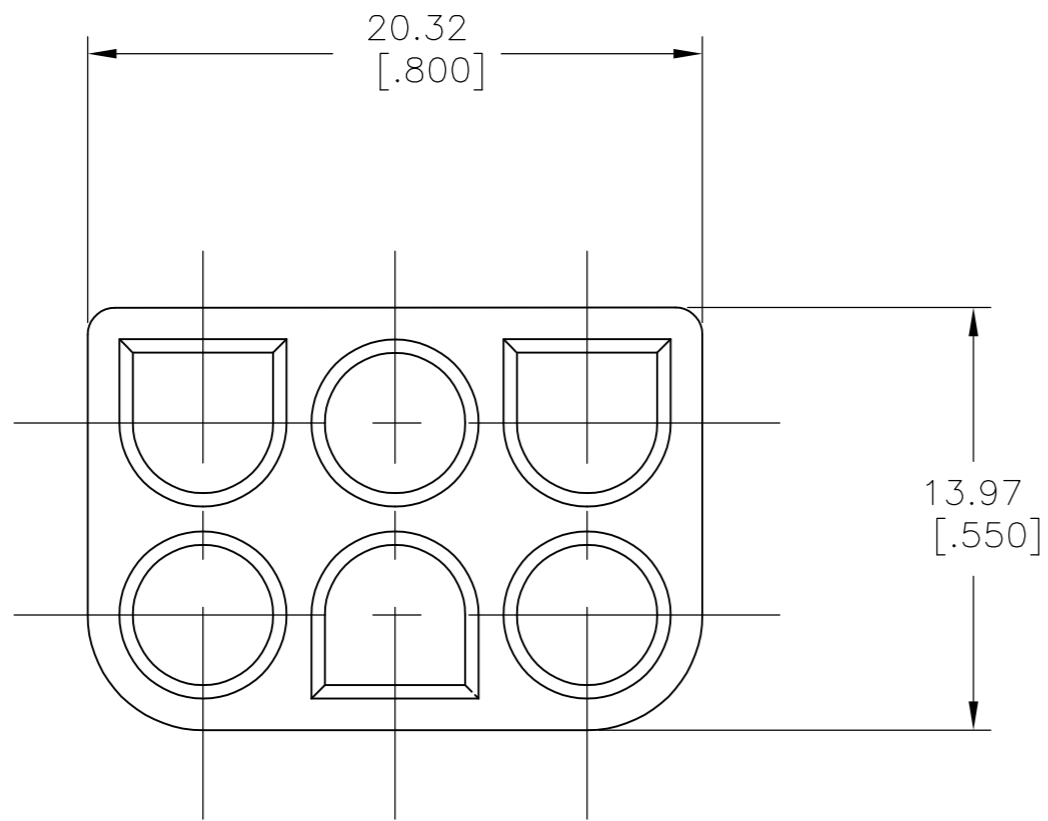

勝特力電材超市-龍山店 886-3-5773766
 勝特力電材超市-光復店 886-3-5729570
 勝特力电子(上海) 86-21-34970699
 勝特力电子(深圳) 86-755-83298787
<http://www.100y.com.tw>

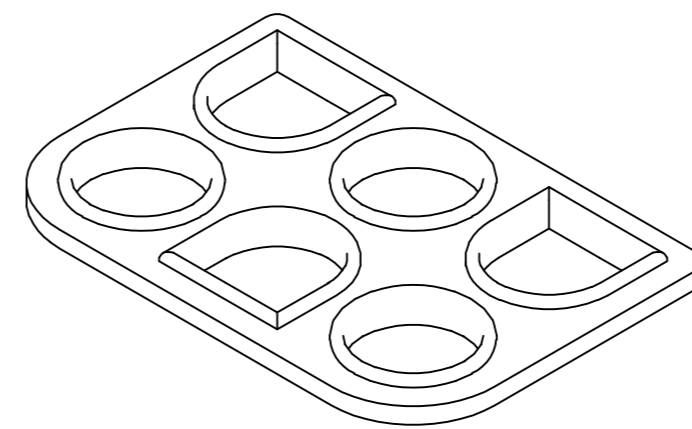
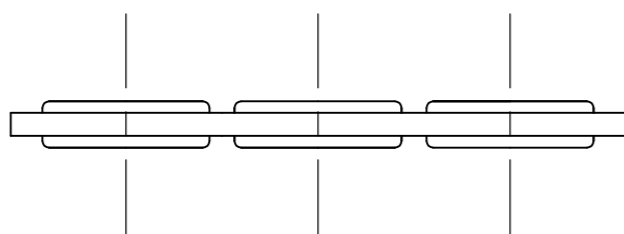

3-DIMENSIONAL MODEL
NTS

794275-1
PART NUMBER

THIS DRAWING IS A CONTROLLED DOCUMENT.		DWN	B. LEWIS	3-25-97	STE TE Connectivity																		
DIMENSIONS: mm [INCHES]		CHK	R. SWING	3-25-97																			
TOLERANCES UNLESS OTHERWISE SPECIFIED:		APVD	D. SELF	3-25-97																			
<table border="0"> <tr><td>0 PLC</td><td>±</td><td>-</td></tr> <tr><td>1 PLC</td><td>±</td><td>-</td></tr> <tr><td>2 PLC</td><td>±</td><td>0.38[.015]</td></tr> <tr><td>3 PLC</td><td>±</td><td>-</td></tr> <tr><td>4 PLC</td><td>±</td><td>-</td></tr> <tr><td>ANGLES</td><td>±</td><td>0°30'</td></tr> </table>		0 PLC	±	-		1 PLC	±	-	2 PLC	±	0.38[.015]	3 PLC	±	-	4 PLC	±	-	ANGLES	±	0°30'	PRODUCT SPEC	NAME	
0 PLC	±	-																					
1 PLC	±	-																					
2 PLC	±	0.38[.015]																					
3 PLC	±	-																					
4 PLC	±	-																					
ANGLES	±	0°30'																					
MATERIAL	FINISH	WEIGHT	SIZE		CAGE CODE	DRAWING NO	RESTRICTED TO																
1	-	-	A2	00779	C=794275	-	-																
CUSTOMER DRAWING			SCALE	4:1	SHEET	1 of 1	REV																
							C																

SPLASH PROOF SEALS			INTERFACE SEAL LOW MATING FORCE‡
NUMBER OF CIRCUITS	WIRE SEALS	INTERFACE SEALS	
2	794270-1	794269-1	794991-1
3	794272-1	794271-1	794992-1
4	794274-1	794273-1	—
6	794276-1	794275-1	794993-1
9	794278-1	794277-1	794994-1
12	794280-1	794279-1	—
15	794282-1	794281-1	—

‡ Low mating force seals do not meet any IP requirements.

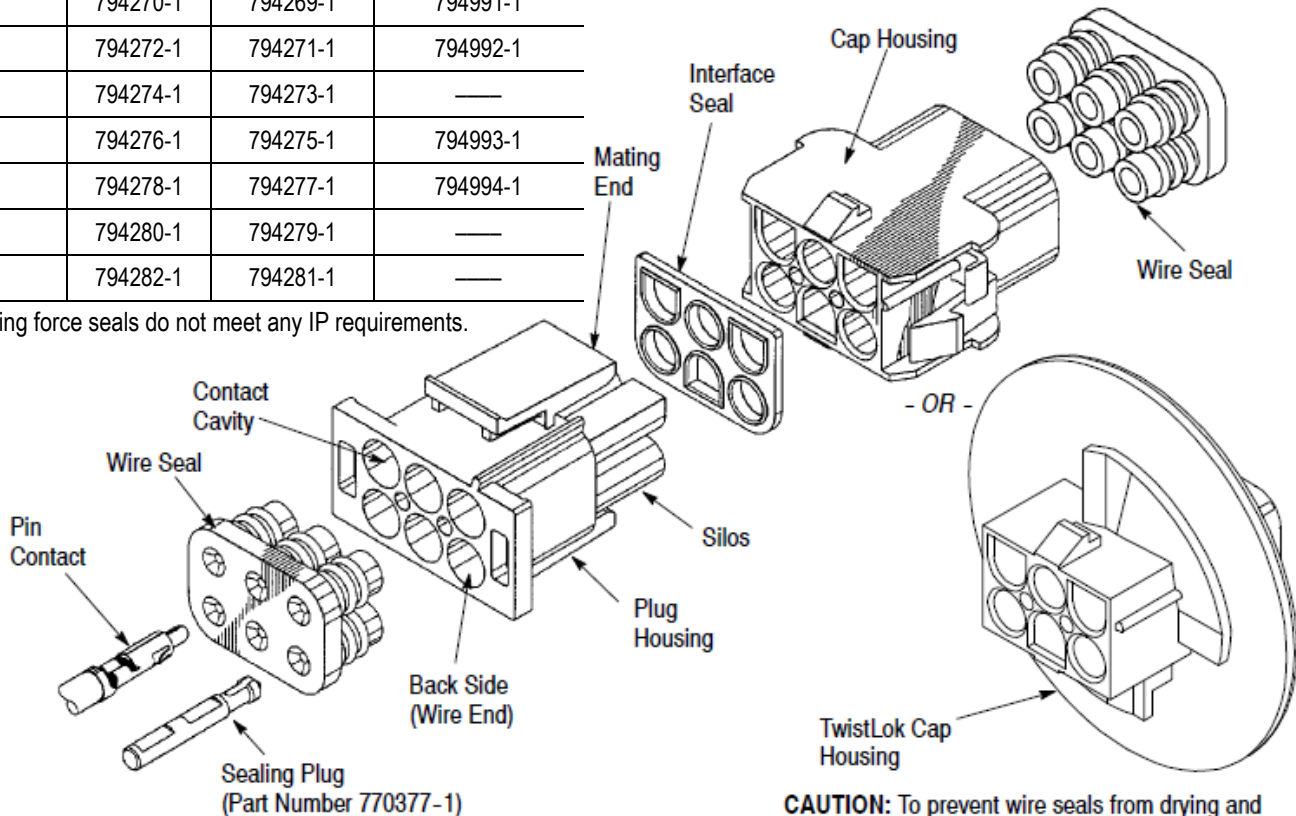

CAUTION: To prevent wire seals from drying and cracking, they should be stored in a sealed bag when not in use.

NOTE: 2.79 to 3.30 [.110 to .130] Insulation diameter tested to IEC 529. IP sealing level #5/7 (Immersion to 1 meter).
1.52 to 2.79 [.060 to .110] Insulation diameter tested to IEC 529. IP sealing level #5/6 (Heavy Seas).

Optional Latching Tool 794381-1

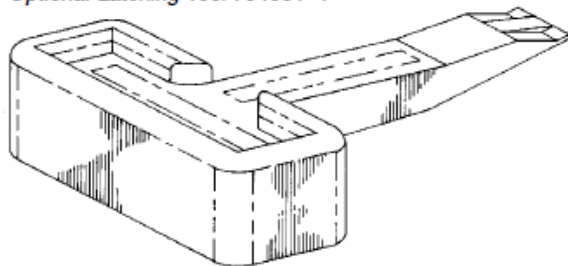

CONTACT SELECTION ■

SIZE (AWG)	INSUL DIA RANGE	PIN	SOCKET
14 to 20	1.52 to 3.30 [.060 to .130]	350669■	350536 350550▲
		350218	
		350547▲	
		350687	
		350705▲	
		350654●	

■ Only contacts in this table may be used with splash proof seals.
▲ Loose piece contact numbers. ■ Loose piece grounding pin.
● Grounding pin.

Figure 1

1. INTRODUCTION

This instruction sheet provides assembly and disassembly procedures for Universal MATE-N-LOK* Splash Proof Seals. The various seal components are shown in Figure 1.



NOTE

All dimensions are in metric units [with U.S. customary units in brackets].

2. DESCRIPTION

The connector seals are designed to ensure a water resistant seal between mated plug and cap housings. One interface seal, two wire seals, and optional sealing plugs are required per assembly.

3. ASSEMBLY PROCEDURES

1. Select appropriate contacts, then follow pin and socket termination procedures shown in Application Specification 114-1010.
2. Assemble interface seal over contact silos of the plug housing as shown in Figure 2.



CAUTION

To prevent damage to the interface seal, use the mating cap to slide the interface seal along the silos until it rests against the mating face of the plug housing.

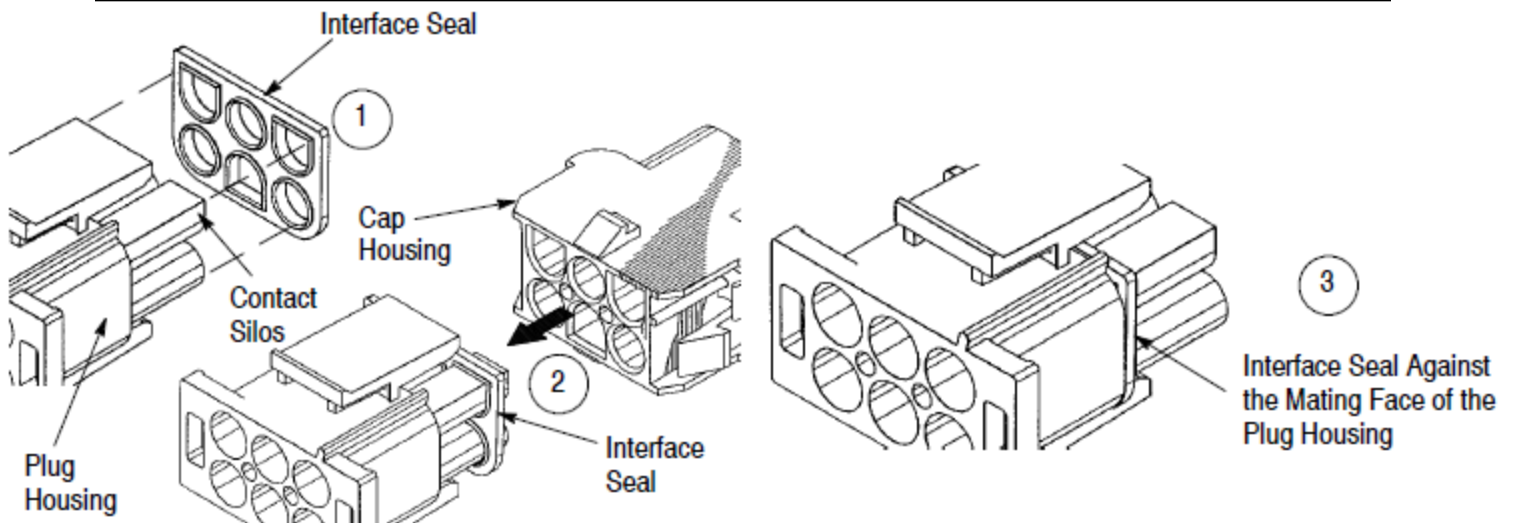

Figure 2

3. Insert wire seals into contact cavities at the back side (wire end) of the cap and plug housings as shown in Figure 3.



NOTE

Contact insertion force will increase when using splash proof seals.

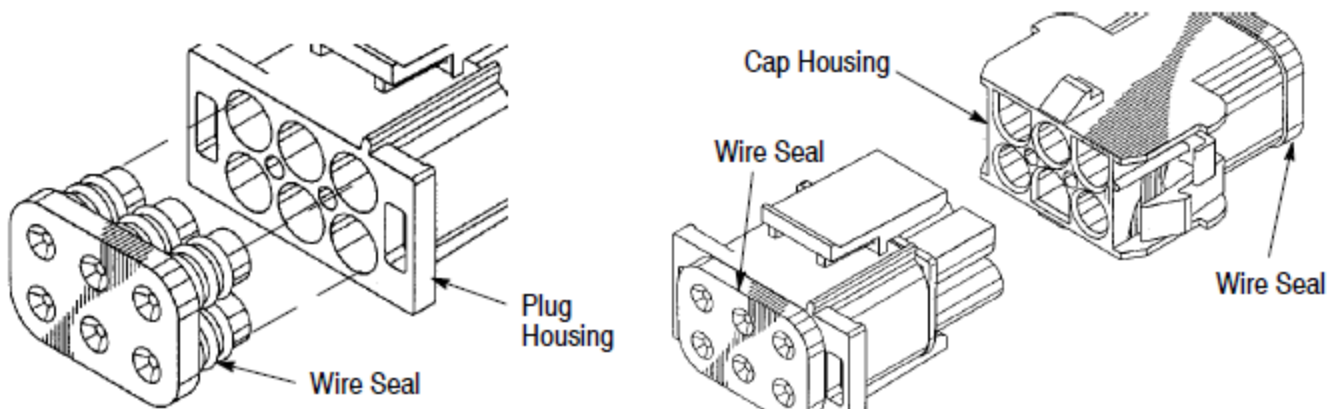

Figure 3

- Align the terminated pin or socket contact with appropriate contact cavity in the back (wire end) of the plug or cap housing. This alignment is to help ensure that the wire seal will not be damaged during the insertion process. Grasp the wire (close behind the contact insulation barrel) and push straight into the cavity until a click is heard, then pull back lightly on the wire to be sure the contact is locked in place. Pin and socket contacts may be inserted in either the plug or cap housing, or they may be intermixed in each housing to provide additional keying combinations. See Figure 4. Insertion Tool 455830-1 is available for inserting contacts.

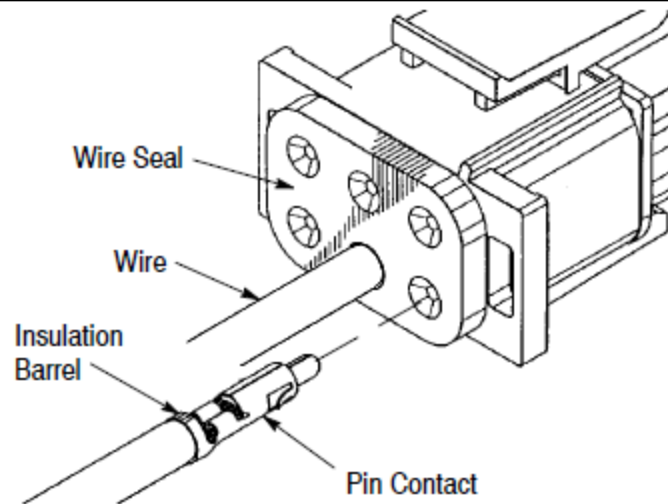

Figure 4



NOTE

Insert a sealing plug in all unused contact cavities of mating housings to provide a water resistant seal between housing.

- Align the split tapered end of the sealing plug with an unused opening in the wire seal. Push the sealing plug through the wire seal and into the housing until it snaps into position as shown in Figure 5. Follow this procedure for all unused openings to provide a water resistant seal between the plug and cap housings. Sealing plugs can be removed from the connector housing. While holding the wire seal, grasp the end of the sealing plug with a pair of needle-nose pliers and pull until it is free of the housing and wire seal.

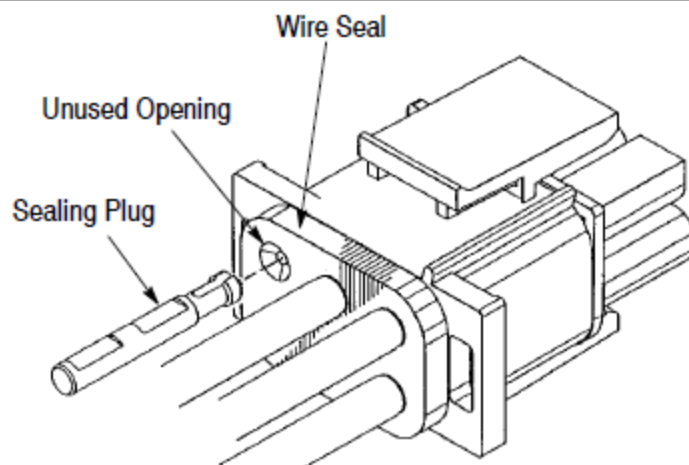

Figure 5

4. MATING CONNECTORS

1. Make sure polarization features are properly oriented. Push plug connector into cap connector until locking latches engage. See Figure 6.

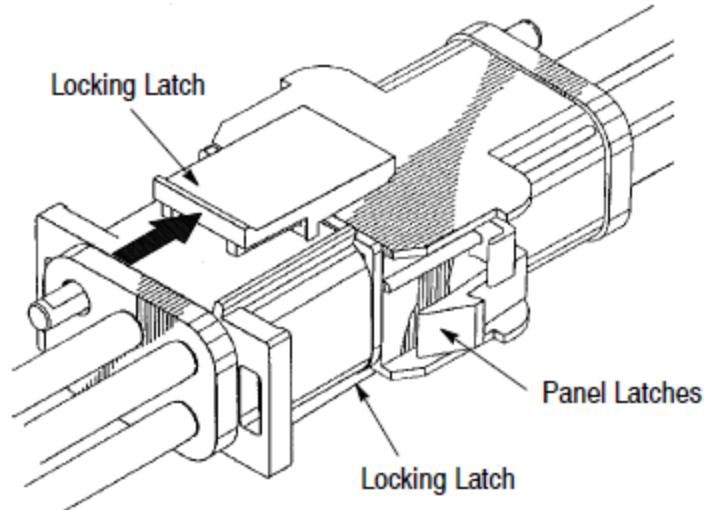

Figure 6

2. Push latch forward with thumb as shown in Figure 7. To aid in connector latching, an optional Latching Tool 794381-1 is available as shown in Figure 8. Slide optional latching tool under the locking latch of the plug housing and push forward until an audible click is heard. Perform this procedure on both locking latches as shown in Figure 8.



NOTE

The optional latching tool should be pushed forward, not lifted.

Push Locking Latch Forward with Thumb Until an Audible Click is Heard. Follow this Procedure for Both Locking Latches

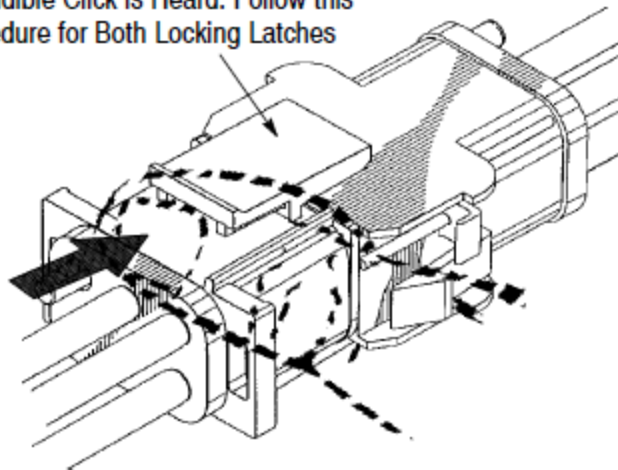
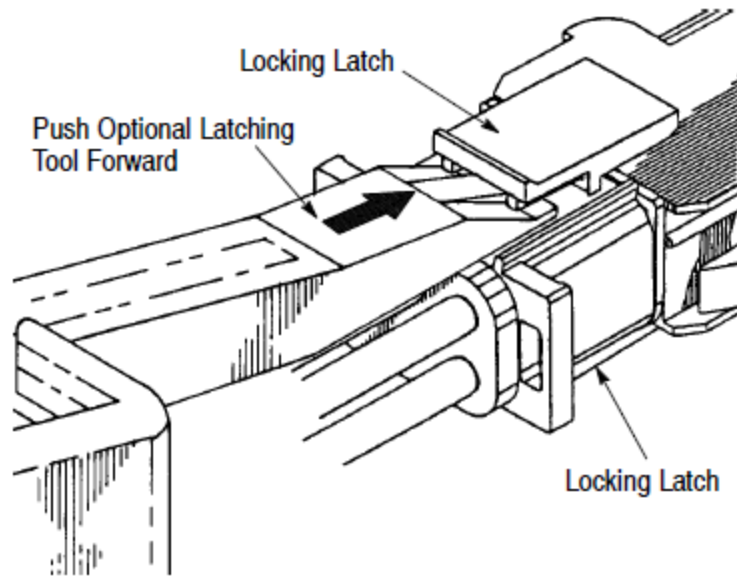
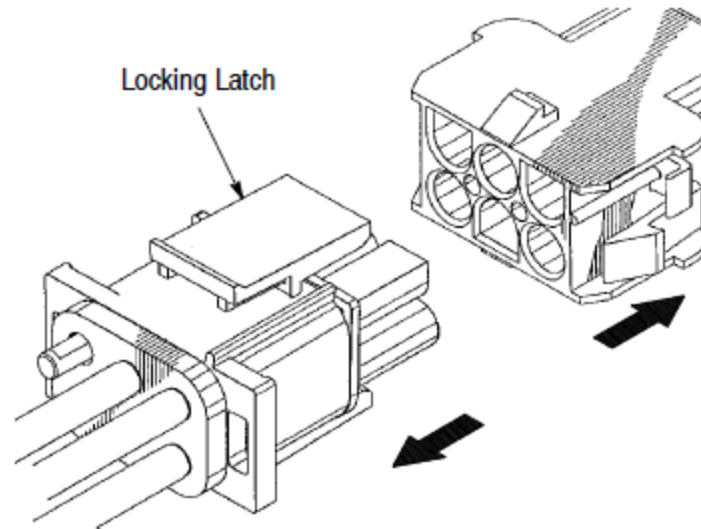

Figure 7

**Figure 8****5. CONTACT EXTRACTION**

1. Depress both locking latches of the plug connector. Pull the cap connector away from the plug connector as shown in Figure 9.

**Figure 9**

2. While holding the wire seal, push the selected wire forward then insert Extraction Tool 318851-1 into contact cavity. Pull the wire lightly until you feel the contact locking lances disengage. Do not pull contact through wire seal at this time. See Figure 10.

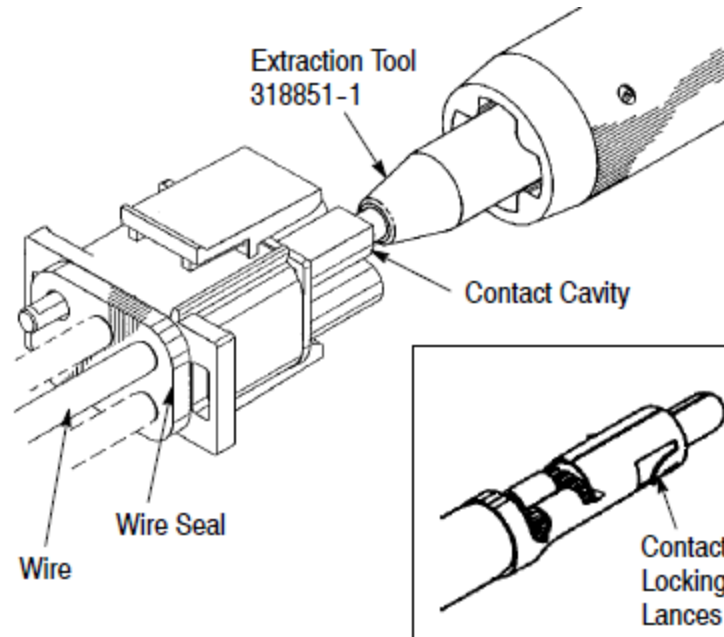
Figure 10

3. Holding the wire seal and housing together, rotate the wire and pull it through wire seal. This technique should prevent damage to the wire seal. See Figure 11.

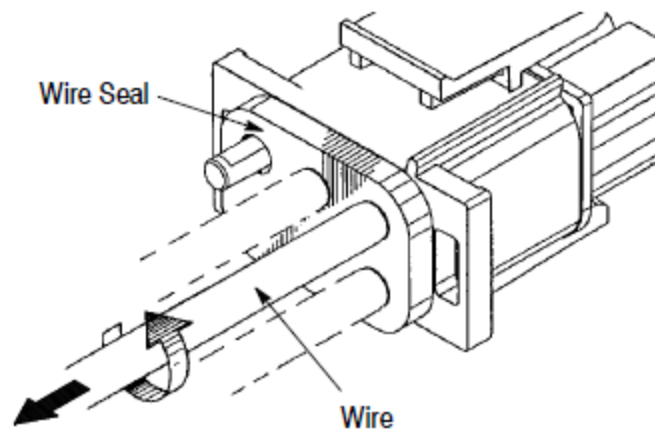

CAUTION: To prevent damage to the wire seal when removing contacts from housing, hold the wire seal and rotate the wire while pulling it through the wire seal.

Figure 11

4. Reset contact locking lances to their original position before re--inserting contacts through wire seal and into housing. Seal any unused cavities with sealing plugs. See Figure 12. Damaged contacts must be replaced.

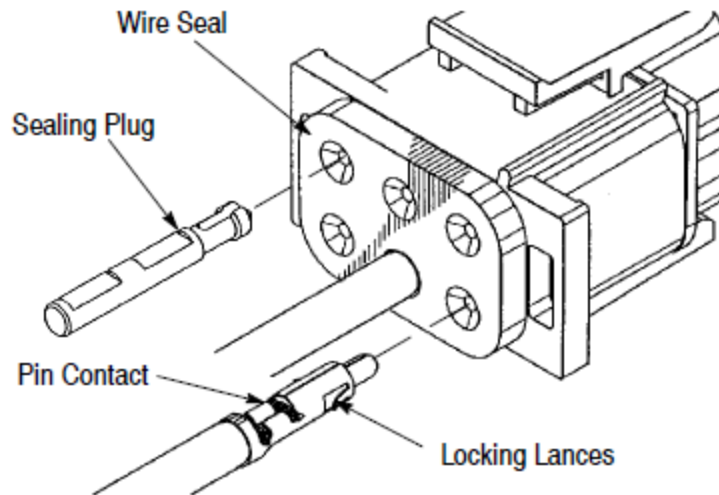

Figure 12

6. REVISION SUMMARY

- Updated document to corporate requirements.
- Added part numbers for interface seal low mating force.