

THIS DRAWING IS UNPUBLISHED. RELEASED FOR PUBLICATION 20
 © COPYRIGHT 20 BY - ALL RIGHTS RESERVED.

LOC	DIST	REVISIONS			
P	LTR	DESCRIPTION	DATE	DWN	APVD
	D2	REVISED PER ECR-20-100299	10AUG2020	BDA	W W

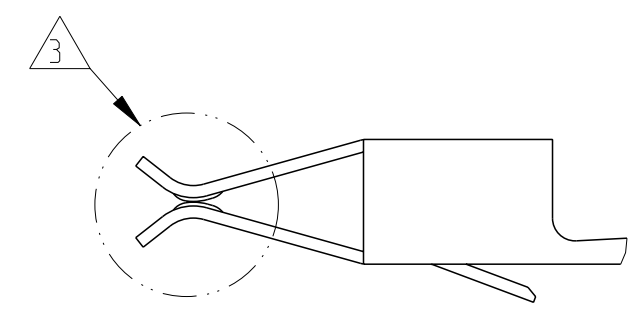
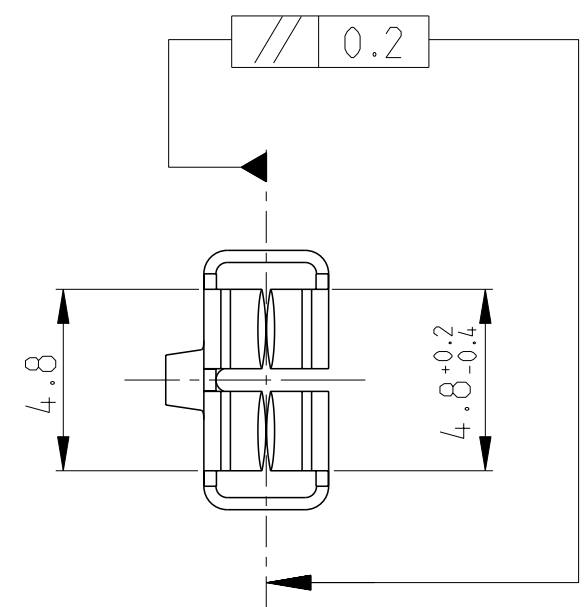
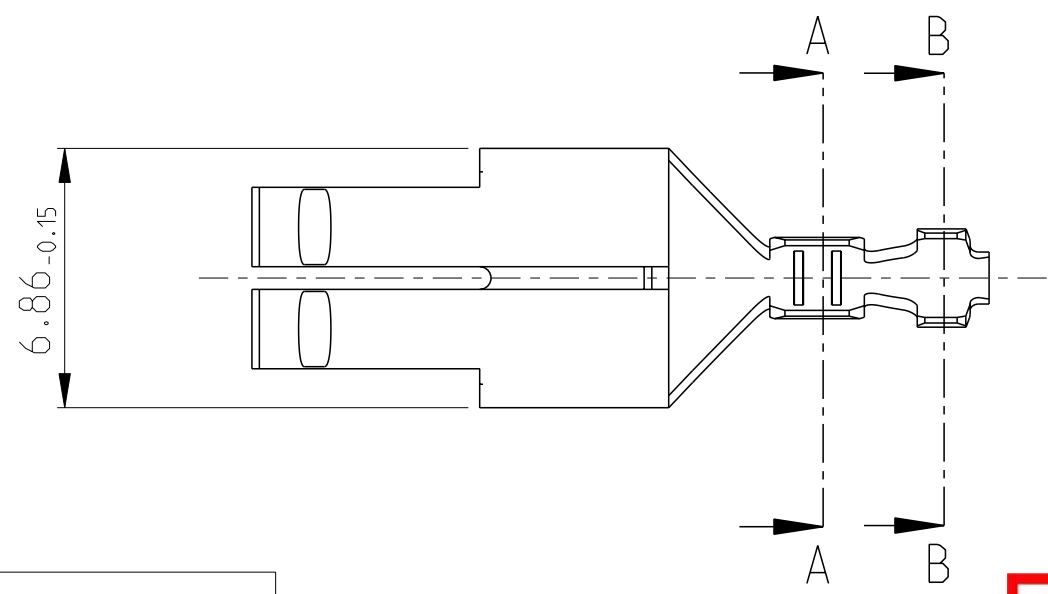
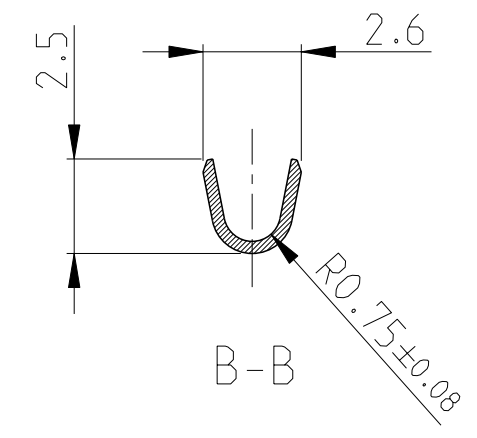
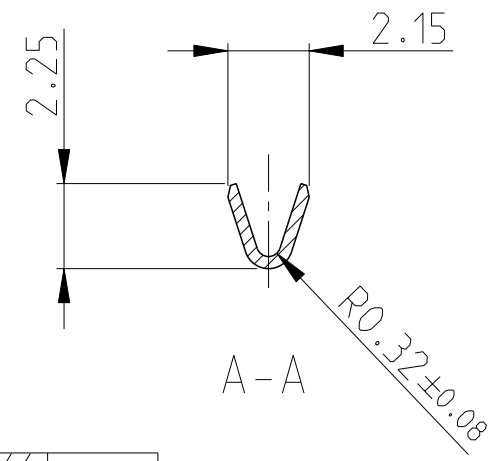
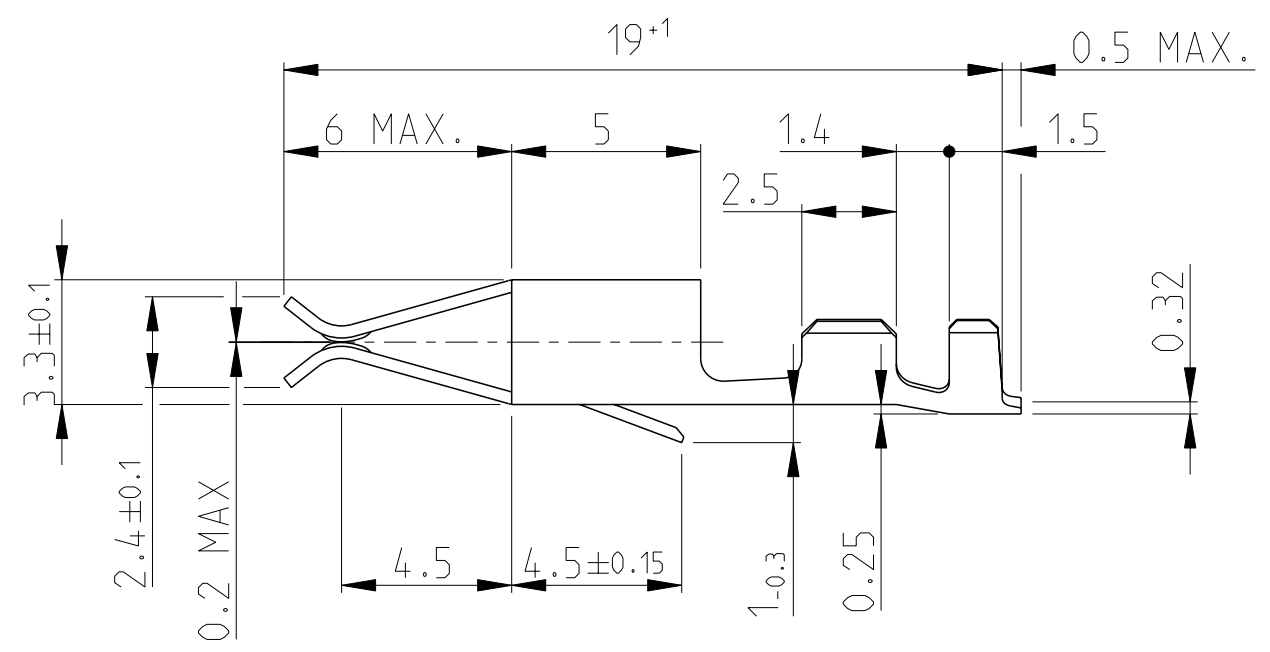

CROSS-SECTION IN mm ²	
SINGLE CONNECTION	
0.20	X
0.25	X
0.35	X
0.50	X

NOTES

- 1 WIRE RANGE 0.2 - 0.5 mm²
- 2 INSULATION RANGE Ø1.0 - 1.6
- 3 SELECTIVE LUBRICATED IN INDICATED AREA WITH ANTI-FREETING LUBRICANT

勝特力電材超市-龍山店 886-3-5773766
 勝特力電材超市-光復店 886-3-5729570
 勝特力電子(上海) 86-21-34970699
 勝特力電子(深圳) 86-755-83298787
<http://www.100y.com.tw>

LOOSE PIECE	FINISH	MATERIAL	PART NO.	REV.
	TIN (vorverzinnt)	CuZn30	△3 1-926984-1	D
926985-2	TIN (vorverzinnt)	CuSn4	926984-2	D
926985-1	TIN (vorverzinnt)	CuZn30	926984-1	D

THIS DRAWING IS A CONTROLLED DOCUMENT.	
DIMENSIONS: mm	TOLERANCES UNLESS OTHERWISE SPECIFIED:
	0 PLC ±
	1 PLC ± ±0.2
	2 PLC ± ±
	3 PLC ± ±
	4 PLC ± ±
	ANGLES ±
MATERIAL -	FINISH -

DWN JS	10-Aug-20
CHK XP	10-Aug-20
APVD RS	10-Aug-20
PRODUCT SPEC	108-18054 (DES. OBJ.)
APPLICATION SPEC	114-18080
WEIGHT	-

STE TE Connectivity

NAME STANDARD TIMER CONTACT

SIZE A3	CAGE CODE 00779	DRAWING NO C-926984	RESTRICTED TO
---------	-----------------	---------------------	---------------

CUSTOMER DRAWING SCALE 5:1 SHEET 1 OF 1 REV D2

Title: STANDARD TIMER CONTACT

Table of contents:

1. SCOPE.....	2
2. REFERENCED DOCUMENTS.....	2
2.1. Customer drawings.....	2
2.2. Product specifications.....	2
2.3. Application specifications.....	2
2.4. Instruction material.....	2
2.5. National/International Standards.....	2
3. DESCRIPTION.....	3
3.1. Contacts for insulation crimp.....	3
4. REQUIREMENTS.....	4
4.1. Wire.....	4
4.2. Cutoff and Burr.....	4
4.3. Wire Crimp.....	4
4.4. Insulation Crimp.....	4
4.5. Contact Area.....	5
4.6. Shape and Position Tolerances.....	5
5. FIGURES AND TABLES	
Fig. 1: Description of contact	
Fig. 2: Shape and Position Tolerances	
Table 1: Crimping Data for STANDARD TIMER CONTACT	

1. INTRODUCTION

This specification contains the guidelines for the application of the STANDARD TIMER CONTACT.

The instructions are intended primarily for automatic or semi-automatic application of all versions (both wires and single-wire sealing), but may also be applied, if agreed, to hand tools.

The contacts are listed in table 1, sorted by their field of application, wire ranges and crimping data.

2. REFERENCED DOCUMENTS

2.1. Customer drawings

There is a customer drawing showing the dimensions and materials of contacts for each part number.

In the case of a conflict between this documents and the customer drawing, the customer drawing takes preference.

2.2. Product specification

The Design Objectives 108-18054 describes the characteristics of these contacts, together with the electrical and mechanical requirements.

2.3. Application specifications

The general guidelines lay down in Application Specifications 114-18022 and 114-18018 also applied to the crimp quality.

2.4. Instruction material

CM 512... Contains information about crimping machines for Miniature Quick Change crimping tools
AI 8025 Describes the Miniature Quick Change crimping tool
IS 6764 Instruction sheet for AMP CERT-LOK hand tool
IS 7424 Explains how to measure the crimp height

2.5. Norms

DIN 72551 T5/05.92 Unscreened low tension cables (FLR)
DIN 72551 T6/01.92 Unscreened low tension cables (FLR)
DIN ISO 6722 T1/04.85 Unscreened low tension cables (FLK)
DIN ISO 6722 T2/04.84 Unscreened low tension cables (FLK)
DIN ISO 6722 T3/08.87 Unscreened low tension cables (FLK)
DIN IEC 352 T2/04.92 Solderless electrical connections, crimped connections

3. DESCRIPTION

The terms shown below are used in this specification.

3.1. Contacts for Wires

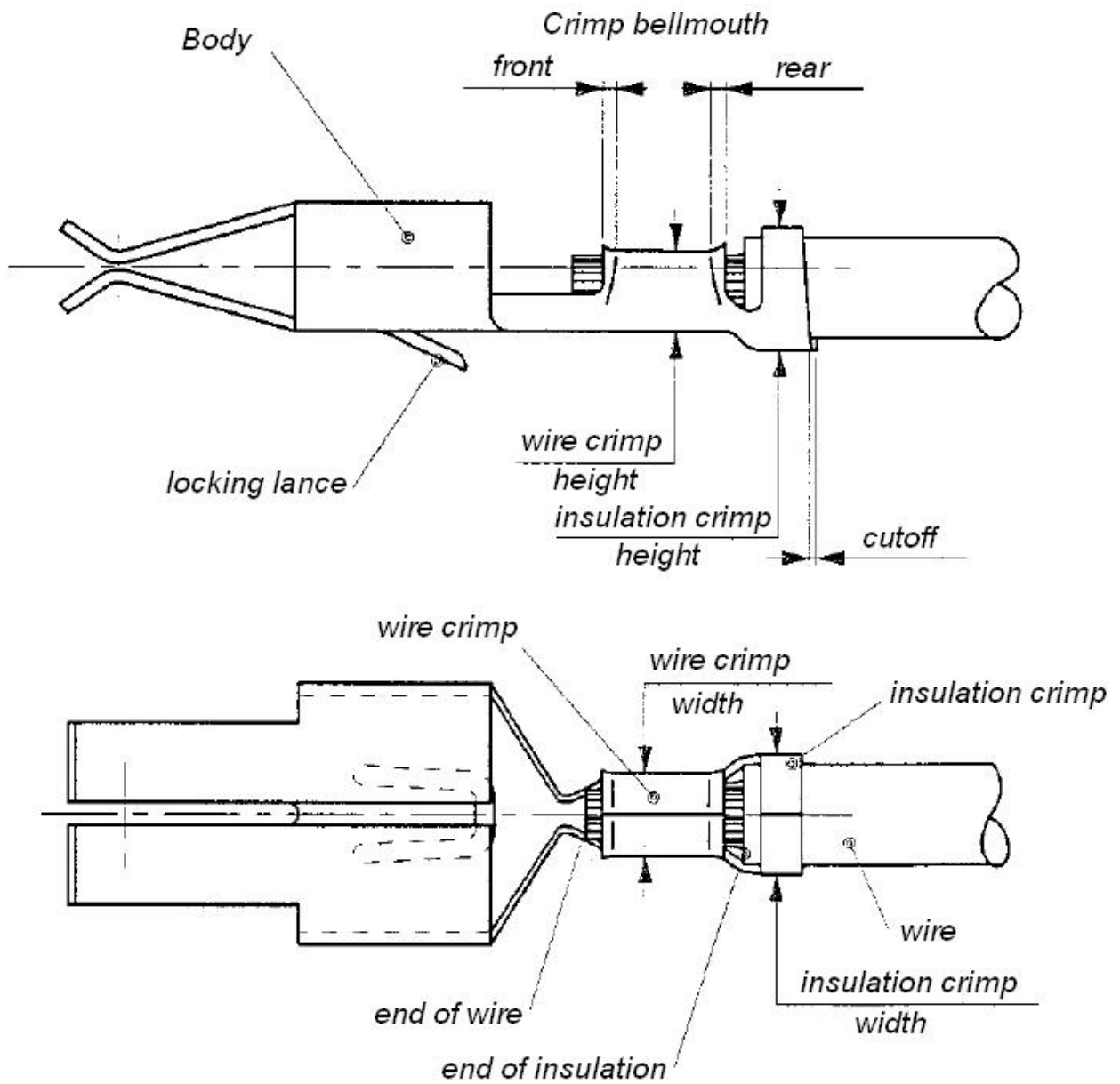

Figure 1

4. REQUIREMENTS

4.1. Wire

A) Selection

The contacts and single-wire seals designed for FLR conductors to DIN72551 Part 5 and Part 6 or FLK conductors to DIN ISO 6722 Parts 1-3 (formerly DIN72551 Part 2).

Other wires require the approval of the Engineering Department. Single termination is preferred. Double termination is possible within the wire range with FLR conductors; with FLK conductors, this is possible only with restrictions.

B) Preparation

The wire must be stripped to the length shown in tables 1.

Take care that the individual strands of the wire are not bent or cut off.

The surface must be clean and free of contamination.

4.2. Cutoff and Burr

The cutoff must be visible after crimping. The maximum length of the cutoff is 0,5mm. Any burrs must be clean and free of contaminations.

4.3. Wire Crimp

A) Wire Position

After crimping, the end of wire must extend 0,1 – 0,5 mm beyond the front end of wire barrel.

B) Crimp data

Crimp shape, height and width & wire range are shown in tables 1 to 5.

C) Extraction forces

Crimp extraction forces must fulfill the requirements of DIN IEC 352 Part 2.

D) Crimp bell mouth

The size of rear bell mouth depends on the wire range:

0,2 to 0,5 mm²: 0,25 +/-0,15 mm

0,5 to 2,5 mm²: 0,40 +/-0,20 mm

Front bell mouth is allowed

4.4. Insulation Crimp

A) Position of the end of insulation

In the case of contacts for crimping on wire, the insulation must be visible in the transition between the wire crimp and the insulation crimp. In no case, the insulation may be crimped in the wire crimp; in addition, the insulation must extend at least to the front edge of the insulation crimp.

B) Crimp data of contacts with insulation crimp

Crimp shape, width and insulation diameter are shown in Table 1.

The crimp height is adjusted according DIN IEC 352.2

4.5. Contact area

After crimping, neither the cantilever spring, the locking lances nor the contact body may be bent or deformed.

4.6. Shape and Position Tolerances

A) Contacts with insulation crimp (Figure 2)

Parallelism

The bottom of the wire and insulation crimp must be parallel with the contact body, within a tolerance of 0,3 mm.

B) Symmetry

The width of the insulation crimp must be symmetrical with the contact body, within a tolerance of 0,6 mm.

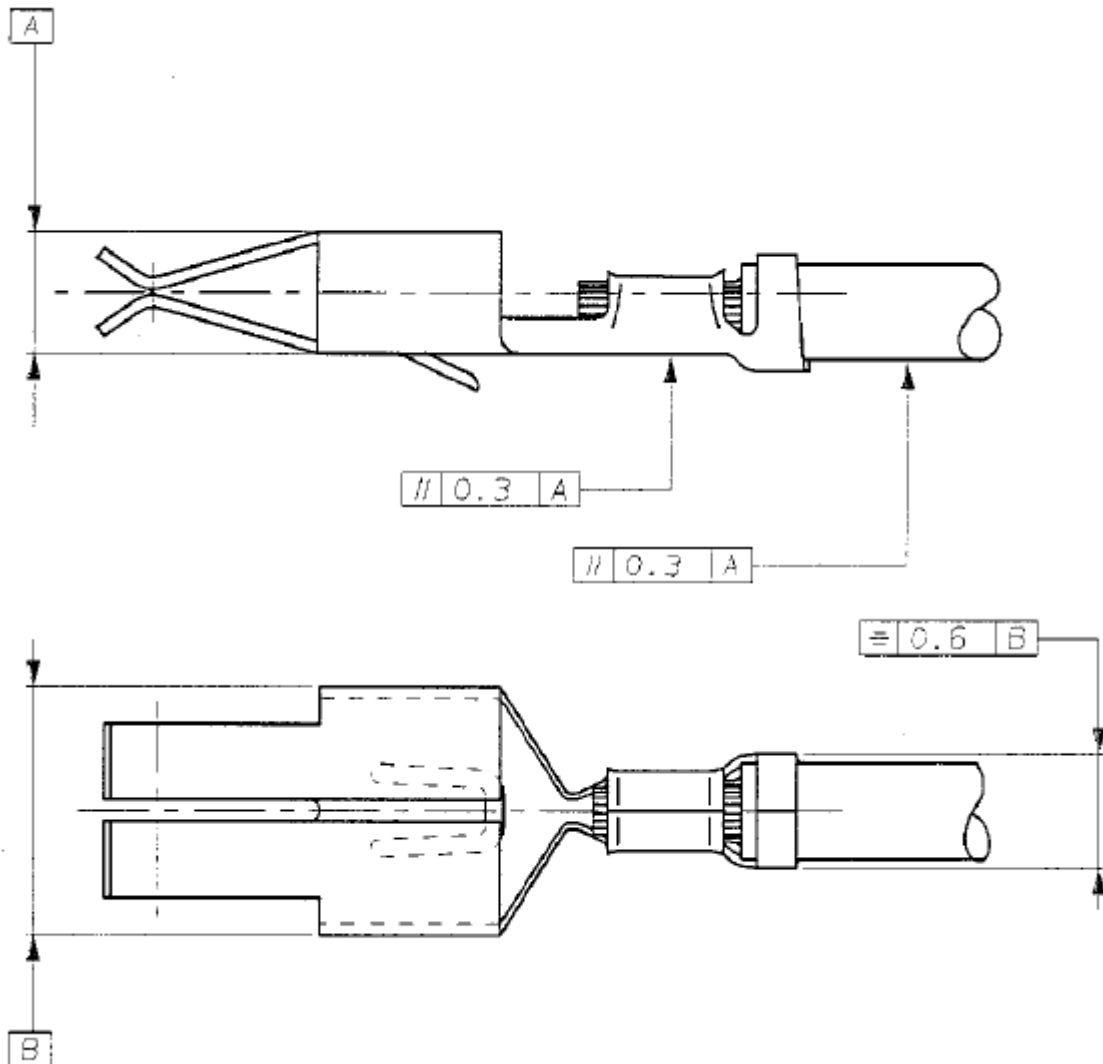

Figure 2

Crimping tool of STANDARD TIMER CONTACT with insulation crimp											
Strip (Loose Piece)	Applicator	Wire size (mm ²)	Insulation type	Insulation diameter (mm)	Insulation strip length (+/- 0,3 mm)	Wire crimp				Insulation crimp	
						Width (mm)	Identification	Height (+/- 0,05)	Shape	Width (+/- 0,2 mm)	Shape
926984 (926985)	872007-2	0,20 0,25 0,37 0,50	FLR	1,0 to 1,6	3,7	1,58	D C B A	0,91 0,93 0,99 1,06	F	2,30	F
927847 (927848)	872093-2	0,50 0,75 1,00	FLR	1,4 to 2,3	4,2	2,03	C B A	1,18 1,27 1,36	F	2,80	OV
927865 (927866)	872144-2	0,50 0,75 1,00	FLK	2,0 to 3,3	-	2,03	C B A	1,18 1,27 1,36	F	3,30	F
925575 (925598)	878035-2	1,00 1,50	FLK	2,0 to 3,0	4,6	2,29	B A	1,38 1,44	F	3,56	F
925612 (925613)	654131-2	1,0 1,25 1,50 1,75 2,0 2,50	FLK	3,0 to 4,3	4,5	2,80	D - C - B A	1,32 1,39 1,45 1,52 1,58 1,70	F	3,94	F
927849 (927850)	872092-2	1,25 1,50 1,75 2,0 2,25 2,50	FLR	2,1 to 3,1	4,5	2,80	- C - B - A	1,44 1,51 1,58 1,64 1,71 1,77	F	3,56	OV
927879 (927880)	878047-2	1,25 1,50 1,75 2,0 2,25 2,50	FLK	2,7 to 4,0	4,2	2,80	- C - B - A	1,44 1,51 1,58 1,64 1,71 1,77	F	3,94	F
926940	658023-2	0,75 (x2)	FLK	2,4 (x2)	-	2,80	A	1,55	F	3,30	F
964201 (1241824)	1426051	0,50 0,75 1,00	FLR	1,4 to 2,3	4,2	2,03	-	1,18 1,27 1,36	F	2,79	OV

964202	1426106	1,50 1,75 2,00 2,50	FLK	2,4 to 3,7	4,5	2,79	-	1,45 1,52 1,58 1,70	F	3,94	F
928820 (1241823)	1426051	0,50 0,75 1,00	FLR	1,4 to 2,3	4,2	2,03	-	1,18 1,27 1,36	F	2,79	OV
969036	1426032	0,50 0,75 1,00 1,25 1,50	FLK	2,0 to 3,0	4,6	2,29	-	1,30 1,34 1,38 1,41 1,44	F	3,56	F
1823562	1530543	0,20 0,25 0,37 0,50	FLR	1,0 to 1,6	3,7	1,57	-	0,91 0,93 0,99 1,06	F	2,29	F

Table 1a

Crimping tool of STANDARD TIMER CONTACT with insulation crimp											
Strip (Loose Piece)	Applicator	Wire size (mm ²)	Insulation type	Insulation diameter (mm)	Insulation strip length (+/- 0,3 mm)	Wire crimp				Insulation crimp	
						Width (mm)	Identification	Height (+/- 0,05)	Shape	Width (+/- 0,2 mm)	Shape
Modified contacts (beveled contact springs)											
926965 (927936)	878035-2	0,50 0,75 1,0 1,50	FLK	2,0 to 3,0	4,6	2,30	D C B A	1,30 1,34 1,38 1,44	F	3,56	F
926973 (927937)	654131-2	1,00 1,25 1,50 1,75 2,00 2,50	FLK	3,0 to 4,3	4,5	2,80	D - C - B A	1,32 1,39 1,45 1,52 1,58 1,70	F	3,94	F

Contacts with wire cantilever spring											
826042 (827808)	654131-2	1,00 1,25 1,50 1,75 2,00 2,50	FLK	3,0 to 4,3	4,5	2,80	D - C - B A	1,32 1,39 1,45 1,52 1,58 1,70	F	3,94	F
Contacts with modified locking lance											
926005 (926007)	878035-2	0,50 0,75 1,00 1,50	FLK	2,3 to 3,3	4,6	2,30	D C B A	1,30 1,34 1,38 1,44	F	3,56	F
926006 (926008)	654131-2	1,00 1,25 1,50 1,75 2,00 2,50	FLK	3,0 to 4,3	4,5	2,80	D - C - B A	1,32 1,39 1,45 1,52 1,58 1,70	F	3,94	F

Table 1b

For information about hand tools to crimp loose piece versions of STANDARD TIMER CONTACT, contact with TE CONNECTIVITY.