

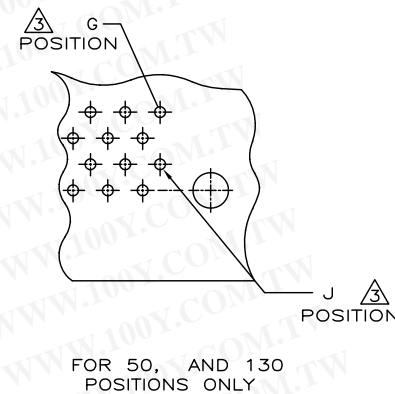

THIS DRAWING IS UNPUBLISHED. RELEASED FOR PUBLICATION AUG ,2006.

© COPYRIGHT BY TYCO ELECTRONICS CORPORATION. ALL RIGHTS RESERVED.

LOC	DIST	REVISIONS			
P	LTR	DESCRIPTION	DATE	DWN	APVD
DW		SEE SHEET 1.			

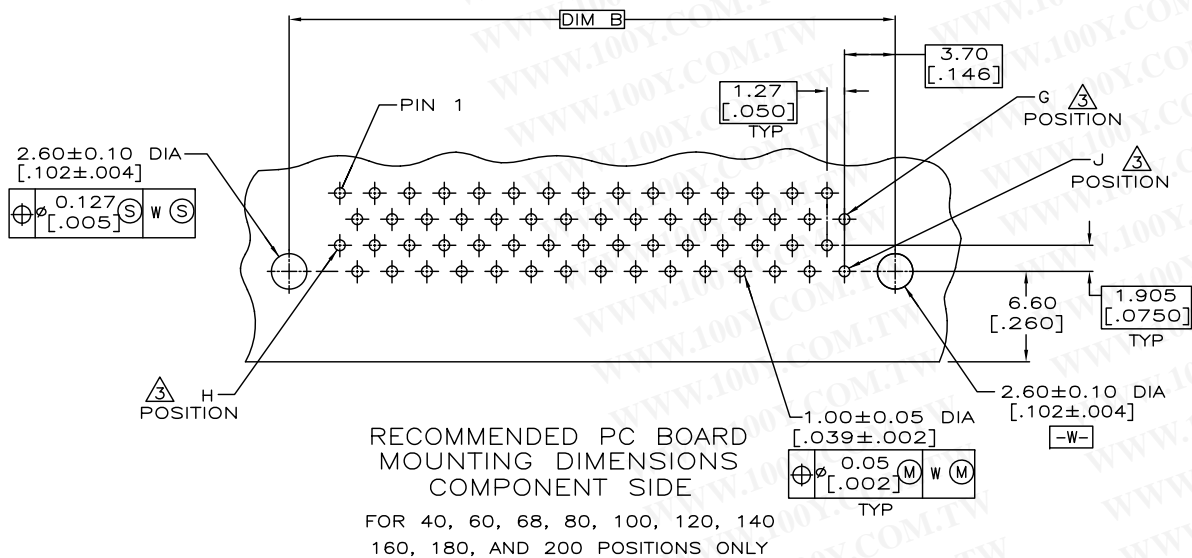

勝特力材料 886-3-5753170  
 勝特力电子(上海) 86-21-34970699  
 勝特力电子(深圳) 86-755-83298787  
 Http://www.100y.com.tw

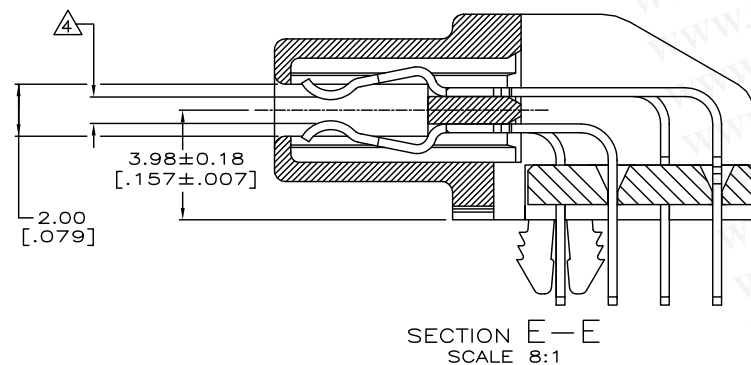
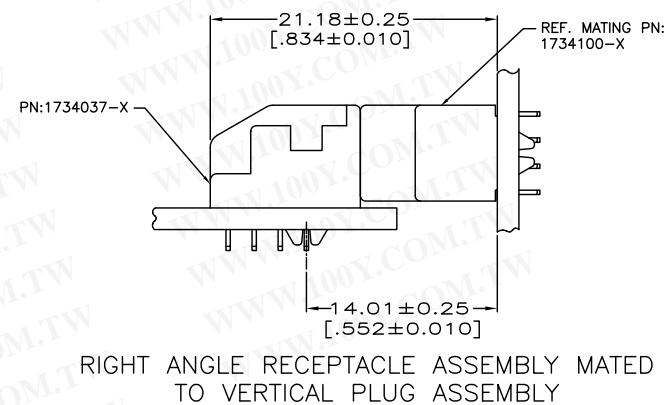
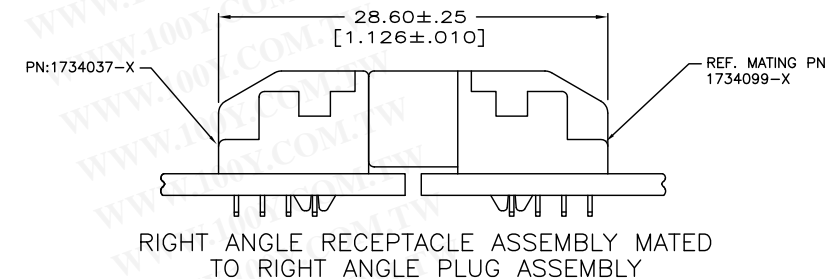
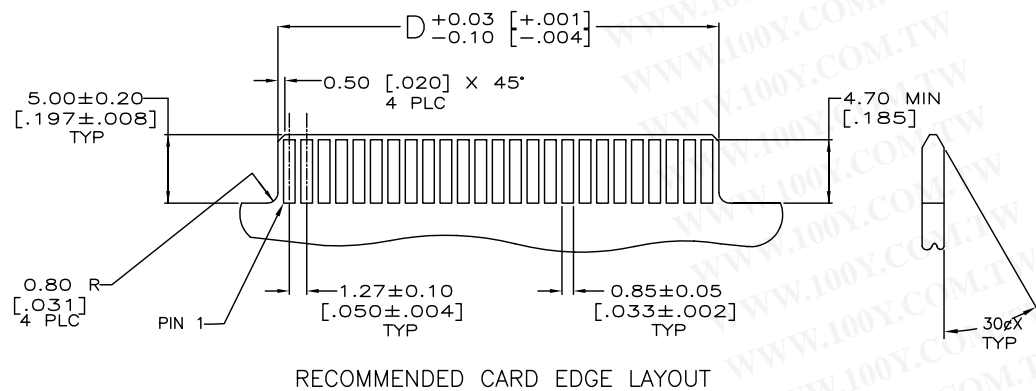

THIS DRAWING IS A CONTROLLED DOCUMENT.		DWN	Tyco Electronics Corporation Tyco Electronics Taipei, Taiwan	
DIMENSIONS: MM		CHK	NAME	
TOLERANCES UNLESS OTHERWISE SPECIFIED:		APVD	RECEPTACLE ASSEMBLY, R/A, BTB, CHAMP.050, SERIES I	
0 PLC ± -		PRODUCT SPEC	SIZE	CAGE CODE
1 PLC ± -		APPLICATION SPEC	A3	00779
2 PLC ± -		WEIGHT	DRAWING NO	
3 PLC ± -		CUSTOMER DRAWING	C=1734037	
4 PLC ± -		SCALE	RESTRICTED TO	
ANGLES ± -		SHEET	2 OF 4	
MATERIAL FINISH		REV	F2	

THIS DRAWING IS UNPUBLISHED.

RELEASED FOR PUBLICATION

AUG ,2006.

© COPYRIGHT - BY TYCO ELECTRONICS CORPORATION. ALL RIGHTS RESERVED.

LOC DW DIST

REVISIONS

P	LTR	DESCRIPTION	DATE	DWN	APVD
		SEE SHEET 1.			

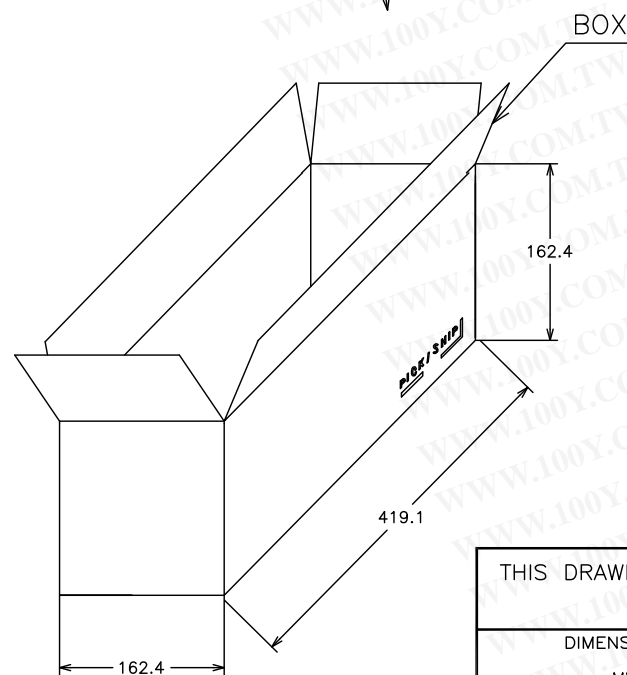
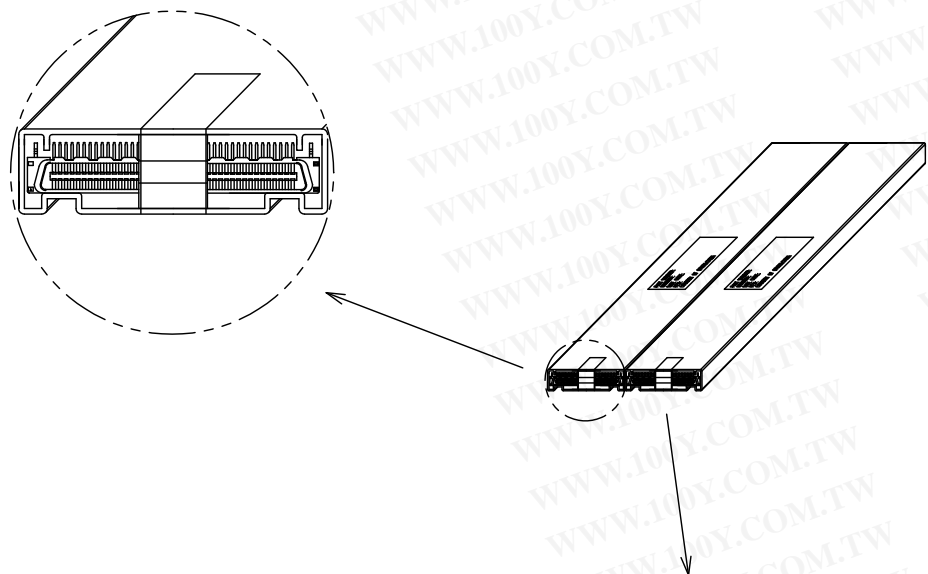
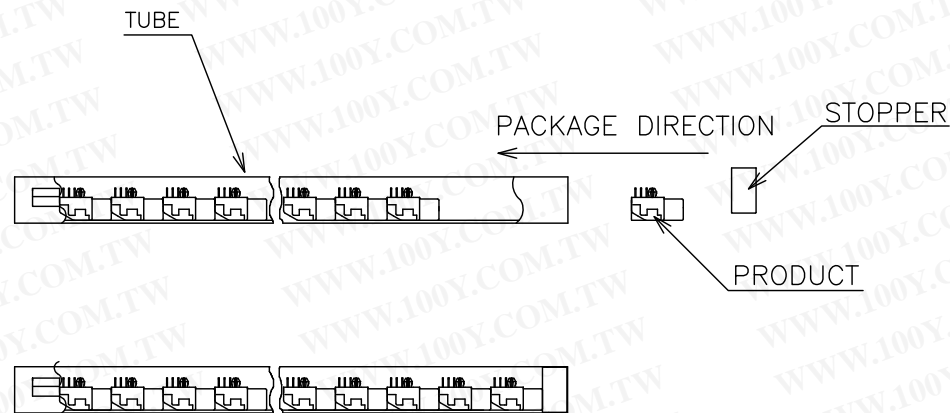

勝特力材料 886-3-5753170  
 勝特力电子(上海) 86-21-34970699  
 勝特力电子(深圳) 86-755-83298787  
 Http://www.100y.com.tw

POS.	Q'TY/ TUBE	TUBE/ BOX	Q'TY/ BOX	N/W (KG)	G/W (KG)	PART NUMBER
	80	21	16	336	2.23	3.07
						6-1734037-2
						4-1734037-2
						2-1734037-2
						1734037-2
	100	21	16	336	2.55	3.40
						5-1734037-0
						3-1734037-0
						1-1734037-0
	80	21	16	336	2.08	2.93
						4-1734037-1
						2-1734037-1
						1734037-1

THIS DRAWING IS A CONTROLLED DOCUMENT.		DWN		Tyco Electronics Corporation Taipei, Taiwan	
DIMENSIONS: MM		CHK			
TOLERANCES UNLESS OTHERWISE SPECIFIED: 0 PLC ± - 1 PLC ± - 2 PLC ± - 3 PLC ± - 4 PLC ± - ANGLES ± -		APVD		NAME RECEPTACLE ASSEMBLY, R/A, BTB, CHAMP.050, SERIES I	
		PRODUCT SPEC			
MATERIAL		FINISH		SIZE CAGE CODE DRAWING NO RESTRICTED TO A3 00779 C=1734037 -	
		WEIGHT		CUSTOMER DRAWING SCALE SHEET 3 OF 4 REV F2	

THIS DRAWING IS UNPUBLISHED.

RELEASED FOR PUBLICATION

AUG ,2006.

© COPYRIGHT BY TYCO ELECTRONICS CORPORATION. ALL RIGHTS RESERVED.

LOC DW DIST

REVISIONS

P	LTR	DESCRIPTION	DATE	DWN	APVD
		SEE SHEET 1.			

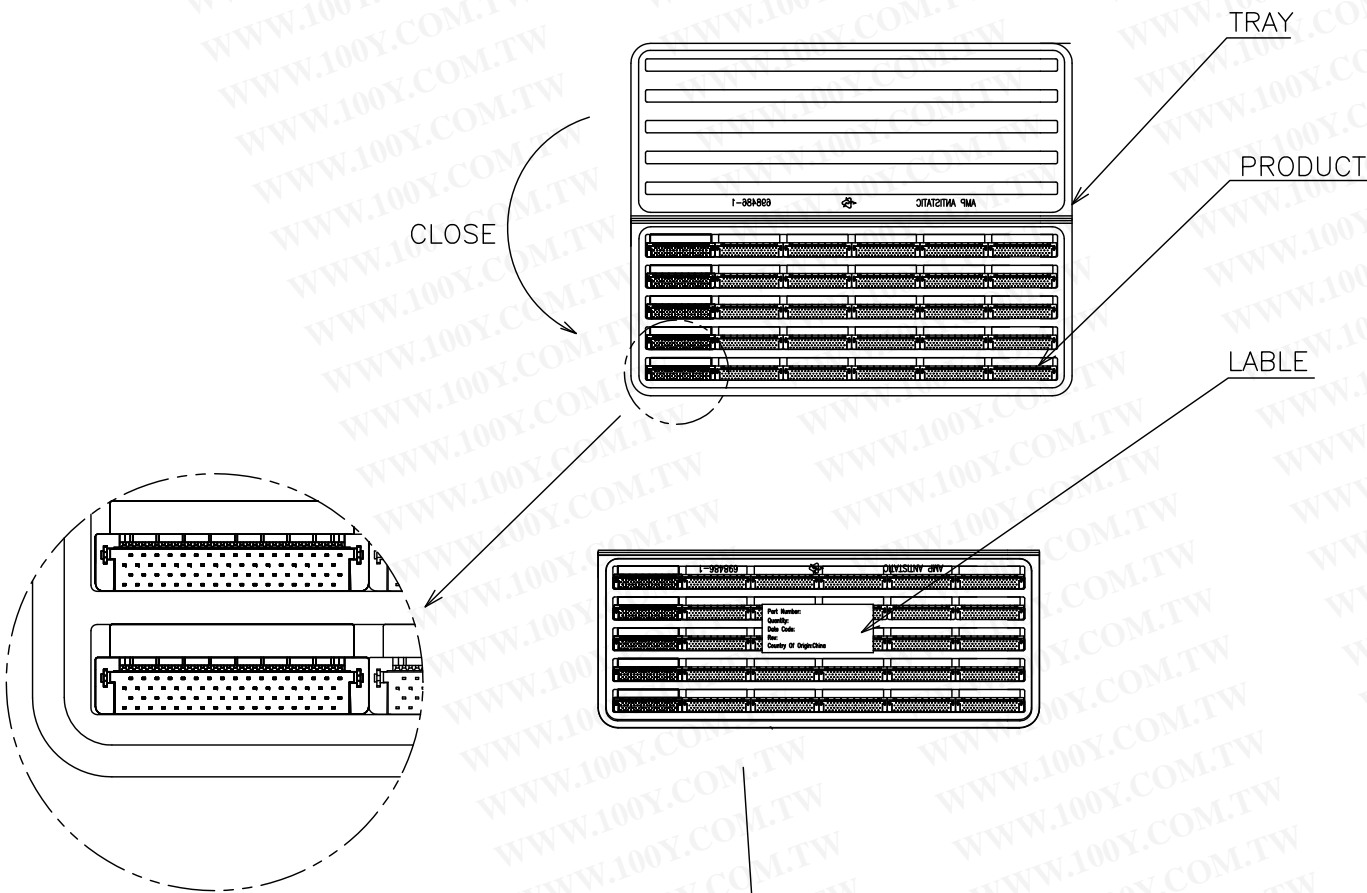

勝特力材料 886-3-5753170  
 勝特力电子(上海) 86-21-34970699  
 勝特力电子(深圳) 86-755-83298787  
 Http://www.100y.com.tw

POS.	Q'TY/ TRAY	TRAY/ BOX	Q'TY/ BOX	N/W (KG)	G/W (KG)	PART NUMBER
	160	10	10	100	1.33	2.28
						5-1734037-6 3-1734037-6 1-1734037-6
	140	15	10	150	1.67	2.62
						5-1734037-4 3-1734037-4 1-1734037-4
	120	15	10	150	1.35	2.30
						2-1734037-0 1-1734037-8 1-1734037-2
	100	20	10	200	1.43	2.43
						5-1734037-1 3-1734037-1 1-1734037-1
	68	30	10	300	1.65	2.60
						4-1734037-7 2-1734037-7 1734037-7
	60	30	10	300	1.60	2.60
						4-1734037-6 2-1734037-6 1734037-6
	50	35	10	350	1.55	2.50
						4-1734037-5 2-1734037-5 1734037-5
	40	45	10	450	1.55	2.45
						4-1734037-4 2-1734037-4 1734037-4

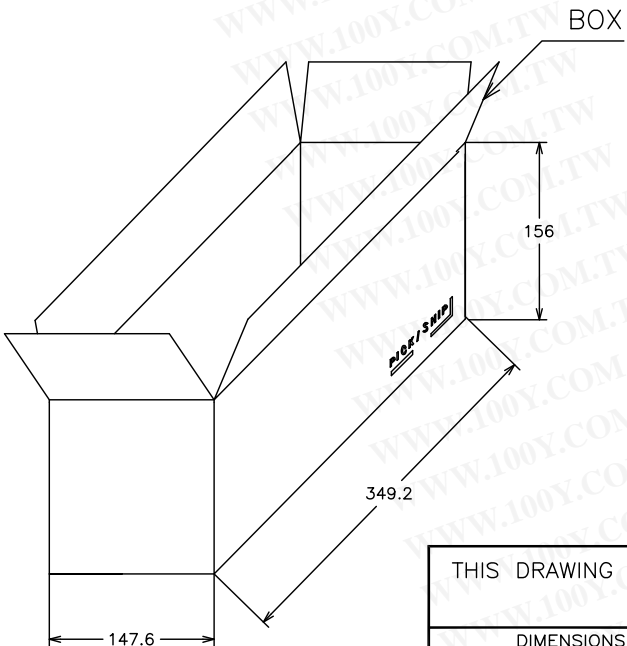

THIS DRAWING IS A CONTROLLED DOCUMENT.		DWN		Tyco Electronics Corporation Taipei, Taiwan	
DIMENSIONS: MM		TOLERANCES UNLESS OTHERWISE SPECIFIED:		NAME	
		0 PLC ± -		RECEPTACLE ASSEMBLY, R/A, BTB, CHAMP.050, SERIES I	
		1 PLC ± -		SIZE CAGE CODE DRAWING NO RESTRICTED TO	
MATERIAL		2 PLC ± -		A3 00779 C=1734037	
		3 PLC ± -		CUSTOMER DRAWING SCALE SHEET 4 OF 4 REV F2	
FINISH		4 PLC ± -			
		ANGLES ± -			
		WEIGHT			