

SIGN	DATE	DESCRIPTION	APPROVER
△	2011.02.06	Soldering temperature ratings added. Plating options detailed.	NL
△	2012.10.29	HT plastic info added; USB 2.0 detail added	NL

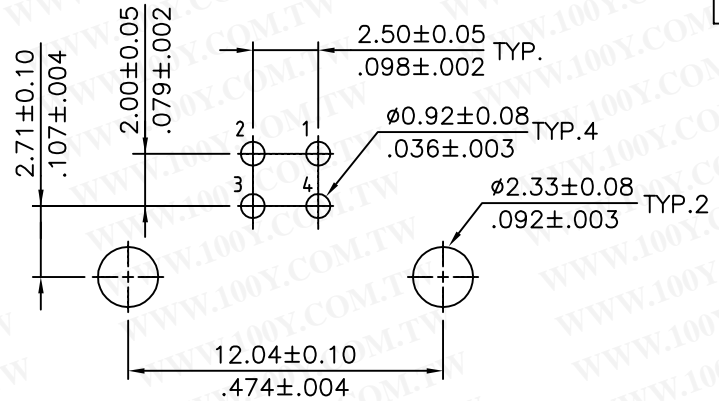

Recommended P.C. Board Layout

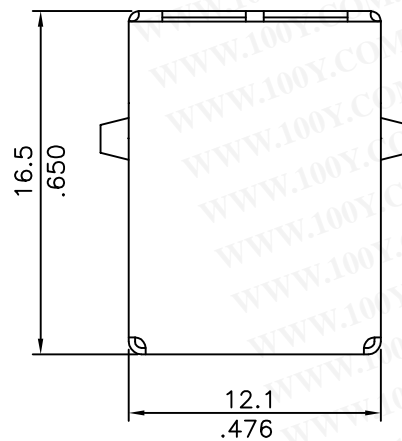
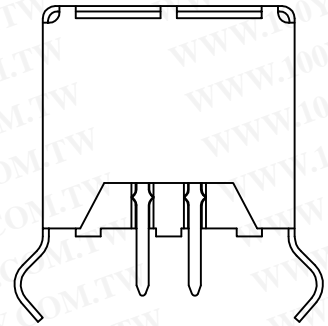
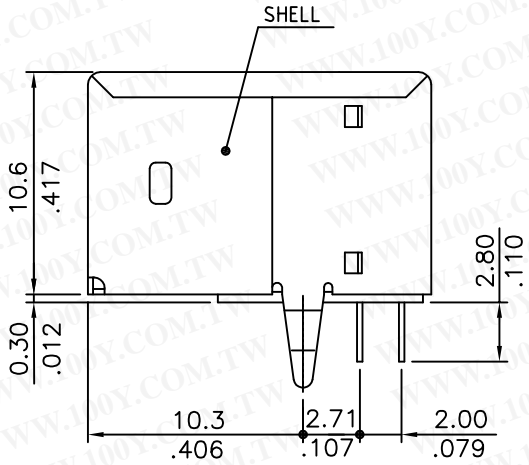
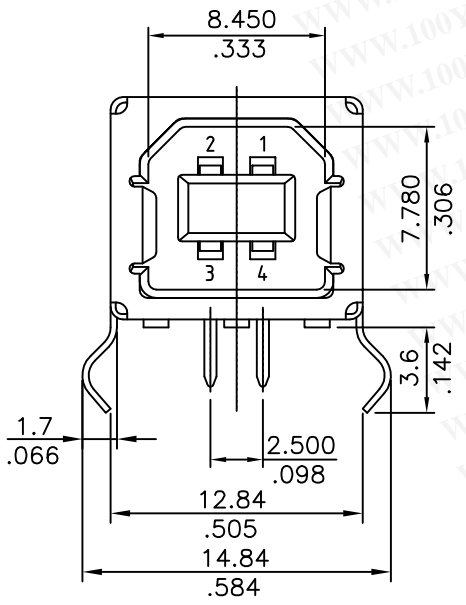

- Material**
- Insulator: Glass Filled Polyester
 - Flammability: UL94V-0
 - Contacts: Phosphor Bronze
 - Contact Plating: See options
 - Shell: Brass
 - Shell Plating: 100u" Min. Tin over 40u" Nickel

- Ratings**
- Current: 1A
 - Voltage: 30V AC(r.m.s.)
 - Dielectric Voltage: 750V AC
 - Contact Resistance: <30mΩ
 - Insulation Resistance: >1,000 MΩ
 - Operating Temperature: -0°C ~ +50°C
 - △ Hi Temp Plastic: -0°C ~ +85°C
 - △ Storage Temperature: -20°C ~ +60°C
 - Solderability: Soldering time 5+/- 0.5 seconds
Soldering pot: 245+/- 5°C
 - △ Resistance to soldering heat: Soldering time 5+/- 0.5 seconds
Soldering pot: 260+/- 5°C

For Hi Temp plastic option - add H at end of part number

RoHS Compliant

PART NUMBER:
USB-B1HSXX

- COLOR:
B: Black
W: White
- PLATING:
6: Selective Au Flash/50u" Ni
8: Selective 30u" Au/50u" Ni (USB 2.0)

勝特力材料 886-3-5753170
勝特力电子(上海) 86-21-34970699
勝特力电子(深圳) 86-755-83298787
[Http://www.100y.com.tw](http://www.100y.com.tw)

THESE DRAWINGS AND SPECIFICATIONS ARE THE PROPERTY OF ON-SHORE TECHNOLOGY, INC. AND SHALL NOT BE REPRODUCED, COPIED OR USED IN ANY MANNER WITHOUT THE PRIOR WRITTEN CONSENT OF ON-SHORE TECHNOLOGY, INC.



TITLE		USB - B type, Horizontal, thru hole			
PART NO.	USB-B1HSXX	DWG NO.	USB-B1HSXX.DWG		
APPROVED	CHECKED	DESIGNED	DRAWN	4050	
Steven 2011.02.06	Marvin 2011.02.06	Marvin 2011.02.06	Marvin 2011.02.06	Tolerance	
				UNIT: mm/inches	X* ±1°
				SCALE: NONE	X.XX ±0.30/.012
				REV.: A	X.XXX ±0.20/.008
SHEET: 01/01					X.XXX ±0.10/.004