



产品编号 : 03092022

系列号 : 1545

Product Category : Connector Housings

Product Description : 2.36mm Diameter Standard .093" Pin and Socket Plug Housing, 2 Circuits, without Mounting Ears, Natural

状态 : Active

工程编号 : 1545-P1

文件和资源

图纸

图纸 003092022_sd.pdf

3D 模型和设计文件

3D模型 003092022_stp.zip

规格

包装规格 PK-1545-001-001.pdf

产品规格 PS-02-09-001.pdf

产品规格 PS-43660-9999-001.pdf

产物环境合规

合规

GADSL/IMDS	Not Relevant
China RoHS	
EU ELV	Not Relevant
Low-Halogen Status	Low-Halogen per IEC 61249-2-21
REACH SVHC	Not Contained per D(2023)8585-DC (23 Jan 2024)
EU RoHS	Compliant per EU 2015/863

多部分产品合规性声明

- Eu RoHS
- REACH SVHC
- Low-Halogen

- IPC 1752A Class C
- IPC 1752A Class D
- Molex Product Compliance Declaration

- IEC-62474

- chemSHERPA (xml)

欧盟 RoHS 合格证书

产品详情

常规

状态	活动
类别	Connector Housings
系列	1545
说明	2.36mm Diameter Standard .093" Pin and Socket Plug Housing, 2 Circuits, without Mounting Ears, Natural
应用	Power, Wire-to-Wire
评论	Glow Wire Equivalent Part Number 50361686; Polarized to Mating Part, 17.0A max. can be achieved when housing is used with 42477 or 42478 terminals
产品系列	Standard .093" Pin and Socket Connectors
产品名称	Standard .093"
UPC	800753614819

机构

CSA	LR19980
UL	E29179

物理

断开	否
电路详图	1x2
电路数 (最多)	2
颜色-树脂	Natural
阻燃性	94V-2
性别	Plug
符合灼热丝规范	否
插接极性	无
锁定插接部位	是

材料 - 树脂	Nylon
净重	1.449/g
行数	1
包装形式	Bag
面板安装式	否
间距 - 插配接口	6.30mm
间距 - 终端界面	6.30mm
可堆叠的	否
运行温度范围	-40° to +105° C

进程

无铅	不适用
----	-----

可配插/可连接使用的产品

可配插部件

描述	产品编号
2.36mm Diameter Standard .093" Pin and Socket Receptacle Housing, 2 Circuits, without Mounting Ears, with Ramps, Natural	<u>03091022</u>
2.36mm Diameter Standard .093" Pin and Socket Receptacle Housing, 2 Circuits, with Pre-bent Mounting Ears, with Ramps, Natural	<u>03091027</u>
2.36mm Diameter Standard .093" Pin and Socket Receptacle Housing without Mounting Ears, Positive Lock, 2 Circuits	<u>03091161</u>
2.36mm Diameter Standard .093" Pin and Socket Receptacle Housing, 2 Circuits, with Pre-bent Mounting Ears, with Ramps, Black	<u>03096021</u>

可连接使用部件

描述	产品编号
Standard .093" Pin and Socket Female Crimp Terminals	<u>1189</u>
Standard .093" Pin and Socket Male Crimp Terminals	<u>1190</u>

Standard .093" Pin and Socket Male Crimp Terminals	<u>1380</u>
Standard .093" Pin and Socket Female Crimp Terminals	<u>1381</u>
Standard .093" Pin and Socket Male Crimp Terminal	<u>1434</u>
Standard .093" Pin and Socket Male Crimp Grounding Terminals	<u>1973</u>

This document was generated on Jul 01, 2024

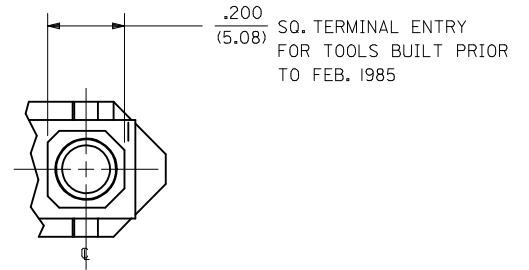
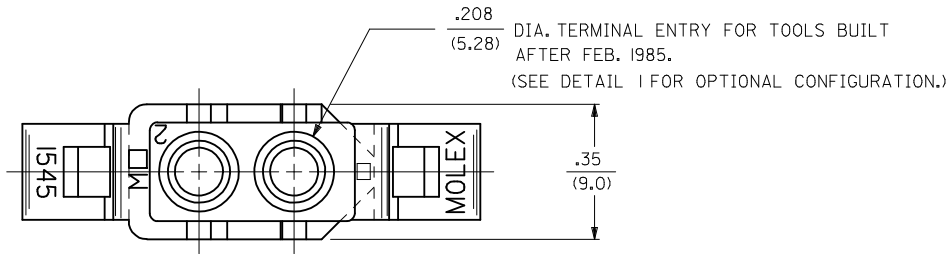

DETAIL "I"

OPTIONAL MOUNTING EARS AND RIBS (PRE-BENT EAR SHOWN) SEE DETAIL 3 & 4

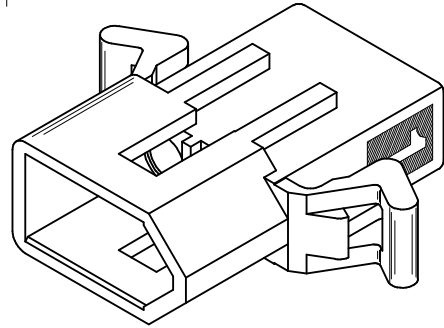
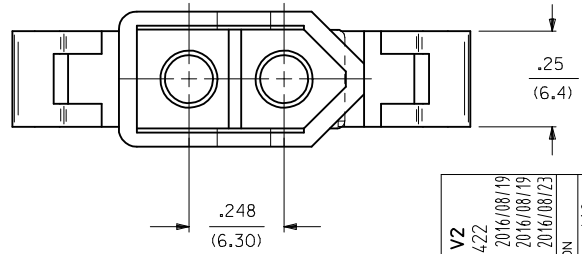
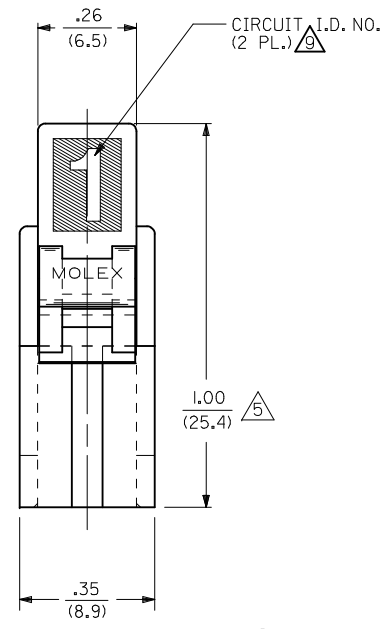
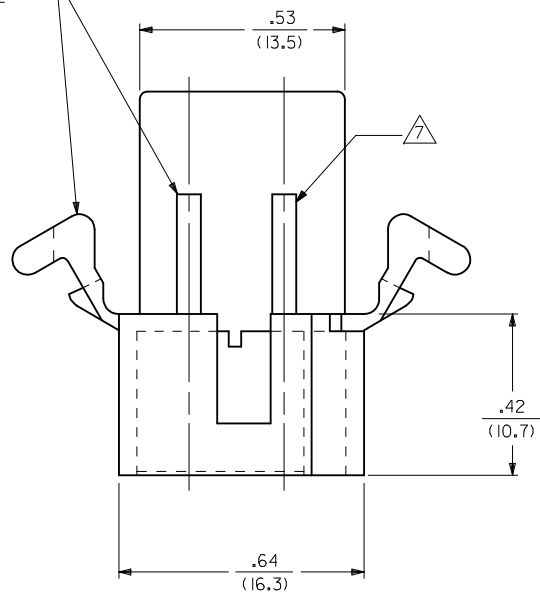
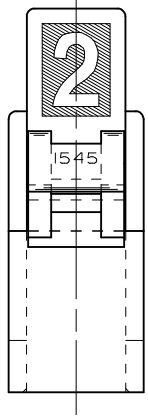

MATERIAL B TO V2 EC NO: UCP2017-0422 DRWN:KIPPER 2016/08/19 CHKD:JBELL 2016/08/19 APPR:FSMITH 2016/08/23	QUALITY SYMBOLS ∇=0 ∇=0 ∇=0	GENERAL TOLERANCES (UNLESS SPECIFIED)		DIMENSION STYLE IN/MM	SCALE 4:1	DESIGN UNITS INCH	THIRD ANGLE PROJECTION	
		4 PLACES ± --- ± ---	DRAWN BY GEP	DATE 8/9/88	.093/(2.36) HOUSING, PLUG & RECEPTACLE, 2 CKT., .248/(6.30) CTR. molex			
		3 PLACES ± --- ± .010	CHECKED BY RW	DATE 8/9/88				
		2 PLACES ± 0.25 ± .014	APPROVED BY FSMITH	DATE 2014/07/10	DOCUMENT NO. SD-1545-*			
1 PLACE ± 0.35 ± ---	DRAFT WHERE APPLICABLE MUST REMAIN WITHIN DIMENSIONS		SHEET NO. 1 OF 3					
0 PLACE ± --- ± ---	ANGULAR ±1/2°		SEE CHART	THIS DRAWING CONTAINS INFORMATION THAT IS PROPRIETARY TO MOLEX INCORPORATED AND SHOULD NOT BE USED WITHOUT WRITTEN PERMISSION				

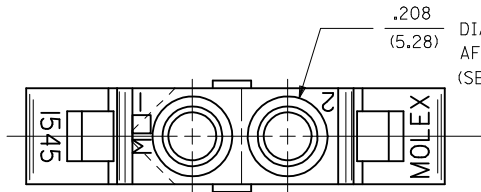

.208
(5.28)
DIA. TERMINAL ENTRY FOR TOOLS BUILT
AFTER FEB. 1985.
(SEE DETAIL 2 FOR OPTIONAL CONFIGURATION.)

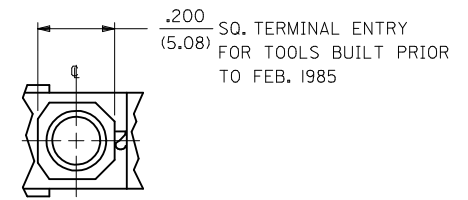

DETAIL "2"

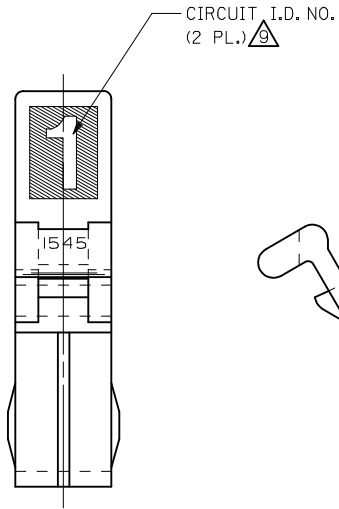

CIRCUIT I.D. NO.
(2 PL.)

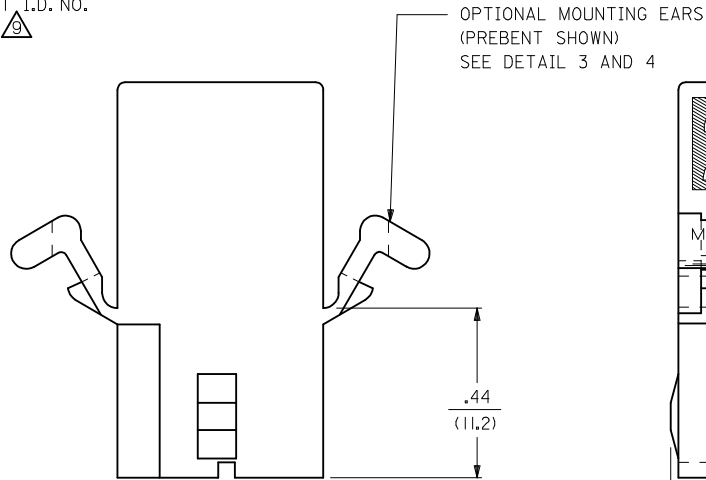

OPTIONAL MOUNTING EARS
(PREBENT SHOWN)
SEE DETAIL 3 AND 4

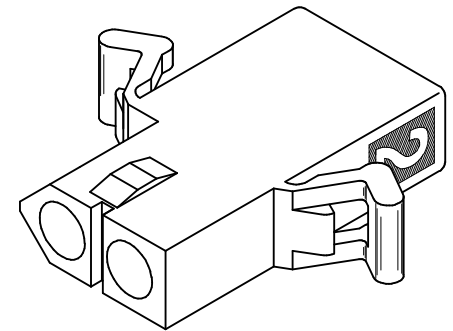
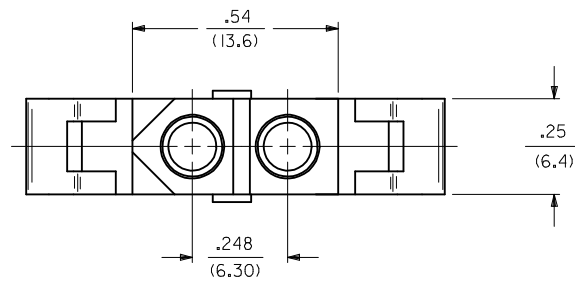
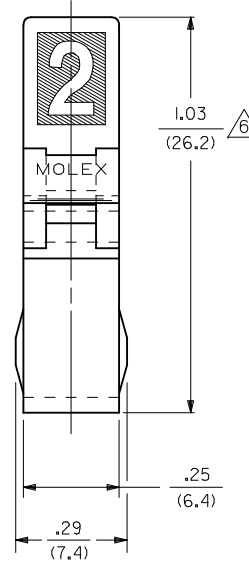

RECEPTACLE

SEE SHEET 1 EC NO: UCP2017-0422 DRW:MKIPPER 2016/08/19 CHKD:JBELL 2016/08/19 APPR:FSMITH 2016/08/23	QUALITY SYMBOLS ▽=0 ▽=0 ▽=0	GENERAL TOLERANCES (UNLESS SPECIFIED)		DIMENSION STYLE IN/MM		SCALE 4:1	DESIGN UNITS INCH	THIRD ANGLE PROJECTION	
			mm	INCH	DRAWN BY GEP	DATE 8/9/88	TITLE .093/(2.36) HOUSING, PLUG & RECEPTACLE, 2 CKT., .248/(6.30) CTR.		
		4 PLACES	± .005	± .005	CHECKED BY RW	DATE 8/9/88			
		3 PLACES	± .005	± .010	APPROVED BY FSMITH	DATE 2014/07/10			
		2 PLACES	± 0.25	± .014					
		1 PLACE	± 0.35	± .---					
		0 PLACE	± .---	± .---					
		ANGULAR ±1/2°		SEE CHART		DOCUMENT NO. SD-1545-*		SHEET NO. 2 OF 3	
		DRAFT WHERE APPLICABLE MUST REMAIN WITHIN DIMENSIONS		THIS DRAWING CONTAINS INFORMATION THAT IS PROPRIETARY TO MOLEX INCORPORATED AND SHOULD NOT BE USED WITHOUT WRITTEN PERMISSION					

PLUG	
PART NO.	ENG. NO.
03-09-2021	I545-P
03-09-2022	I545-P1
03-09-7021	I545-PBK
03-09-7022	I545-P1BK
03-09-2023	I545-P2
03-09-7024	I545-P1RD
03-09-7023	I545-P1BU
50-36-1686	I545-P1-1

RECEPTACLE	
PART NO.	ENG. NO.
03-09-6021	I545-R3BK
03-09-6023	I545-R3RD
03-09-6024	I545-R3BU
03-09-1022	I545-R1
03-09-1023	I545-R2
03-09-6025	I545-R1BU
03-09-1027	I545-R3
50-36-1685	I545-R1-1

LEGEND : PLUG

1545-P*****

OPTIONS: _____

BLANK = WITH STD. EARS
 1 = WITHOUT EARS
 2 = WITH PREBENT EARS

COLOR: BLANK=NATURAL COLOR _____

AM=AMBER BK=BLACK BU=BLUE
 BN=BROWN GY=GRAY GN=GREEN
 OR=ORANGE RD=RED YW=YELLOW

*APPLIES TO MATERIAL A ONLY
 MATERIAL B ONLY AVAILABLE IN BLACK

BLANK = MATERIAL CODE A _____
 1 = MATERIAL CODE B

LEGEND : RECEPTACLE

1545-R*****

BLANK = WITH STD. EARS & RAMPS _____
 1 = WITHOUT EARS, WITH RAMPS
 2 = WITHOUT EARS, WITHOUT RAMPS
 3 = WITH PREBENT EARS & RAMPS

COLOR: BLANK=NATURAL COLOR _____

AM=AMBER BK=BLACK BU=BLUE
 BN=BROWN GY=GRAY GN=GREEN
 OR=ORANGE RD=RED YW=YELLOW

*APPLIES TO MATERIAL A ONLY
 MATERIAL B ONLY AVAILABLE IN BLACK

BLANK = MATERIAL CODE A _____
 1 = MATERIAL CODE B

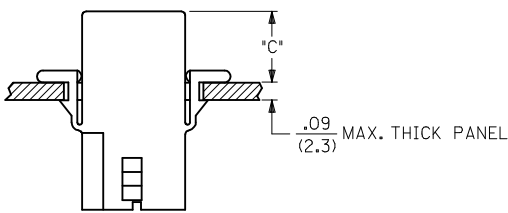

RECOMMENDED PANEL OPENING
(SCALE 2:1)

HOUSING	DIM. "A"	DIM. "B"	DIM. "C" (PREBENT)	DIM. "C" (STD. EAR)
PLUG	.800/(20.32)	.375/(9.53)	.40/(10.2)	.39/(9.9)
RECEPTACLE	.725/(18.42)	.312/(7.92)	.41/(10.4)	.40/(10.2)

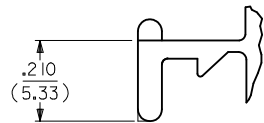

DETAIL 3
.093/(2.36) STANDARD MOUNTING EAR

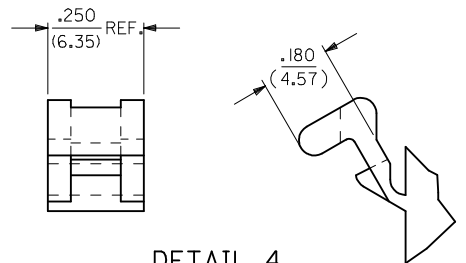

DETAIL 4
.093/(2.36) PREBENT MOUNTING EAR

NOTES:

- MATERIAL: - A = NYLON, PA66, 94V-2. COLOR: SEE LEGEND.
 B = PA6 NYLON, UL94V-2, GLOW WIRE CAPABLE PER IEC 60335-1. COLOR: BLACK
- FINISH: NONE.
- PRODUCT SPECIFICATION: PS-02-09.
- PACKAGING INFORMATION: PK-1545-001
- .97/(24.6) REF. FOR TOOLS BUILT PRIOR TO FEB. 1985.
- 1.00/(25.4) REF. FOR TOOLS BUILT PRIOR TO FEB. 1985.
- RIBS ARE PRESENT ONLY ON PARTS WITH MOUNTING EARS.
- EACH TERMINAL POCKET WILL ACCEPT UP TO:
 (2) #18 AWG WIRES HAVING 1/32" THK. INSULATION OR
 (1) #16 AWG WIRE HAVING 1/16" THK. INSULATION OR
 (1) #16 AWG & (1) #18 AWG WIRE HAVING 1/32" THK. INSULATION .
- CIRCUIT I.D. NUMBERS ON SIDE OF HOUSING APPEAR ON PARTS FROM TOOLS BUILT AFTER 11/25/91.
- PARTS CONFORM TO CLASS 'B' REQUIREMENTS OF COSMETIC SPECIFICATION PS-45499-002 EXCEPT MATERIAL OPTION 'B' MEETS CLASS 'C' REQUIREMENTS FOR SINK AND DISCOLORATION.

SEE SHEET 1 EC NO: UCP2017-0422 DRW:MK/PPR 2016/08/19 CHKD:JBELL 2016/08/19 APPR:FSM/TH 2016/08/23	QUALITY SYMBOLS ▽=0 ▽=0 ▽=0	GENERAL TOLERANCES (UNLESS SPECIFIED)	DIMENSION STYLE IN/MM	SCALE 4:1	DESIGN UNITS INCH	THIRD ANGLE PROJECTION																	
		<table border="1"> <thead> <tr> <th></th> <th>mm</th> <th>INCH</th> </tr> </thead> <tbody> <tr> <td>4 PLACES</td> <td>± ---</td> <td>± ---</td> </tr> <tr> <td>3 PLACES</td> <td>± ---</td> <td>± .010</td> </tr> <tr> <td>2 PLACES</td> <td>± 0.25</td> <td>± .014</td> </tr> <tr> <td>1 PLACE</td> <td>± 0.35</td> <td>± ---</td> </tr> <tr> <td>0 PLACE</td> <td>± ---</td> <td>± ---</td> </tr> </tbody> </table>		mm	INCH	4 PLACES	± ---	± ---	3 PLACES	± ---	± .010	2 PLACES	± 0.25	± .014	1 PLACE	± 0.35	± ---	0 PLACE	± ---	± ---	DRAWN BY GEP DATE 8/9/88	DATE 8/9/88	TITLE .093/(2.36) HOUSING, PLUG & RECEPTACLE, 2 CKT., .248/(6.30) CTR.
			mm	INCH																			
		4 PLACES	± ---	± ---																			
3 PLACES	± ---	± .010																					
2 PLACES	± 0.25	± .014																					
1 PLACE	± 0.35	± ---																					
0 PLACE	± ---	± ---																					
DRAFT WHERE APPLICABLE MUST REMAIN WITHIN DIMENSIONS	APPROVED BY FSM/TH DATE 2014/07/10	MATERIAL NO. SEE CHART	DOCUMENT NO. SD-1545-*	SHEET NO. 3 OF 3																			
THIS DRAWING CONTAINS INFORMATION THAT IS PROPRIETARY TO MOLEX INCORPORATED AND SHOULD NOT BE USED WITHOUT WRITTEN PERMISSION																							