



产品编号 : [08650815](#)

Product Description : KK 254 Crimp Terminal 6459, 22-30 AWG, Reel, Phosphor Bronze Selective Gold (Au)

系列号 : 6459

状态 : Active

Product Category : Crimp Terminals

工程编号 : 6459-(555)

Packaging Alternative : 0008650816 (Bag)

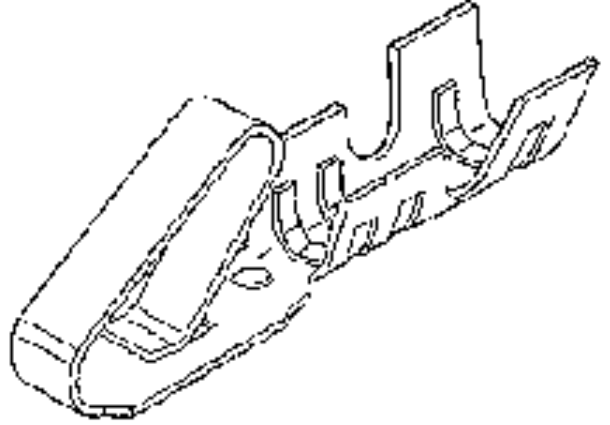

文件和资源

图纸

[图纸 008650815_sd.pdf](#)

[包装设计图 PK-2759-002-001.pdf](#)

规格

[产品规格 PS-10-07-001.pdf](#)

[测试摘要 TS-10-07-001.pdf](#)

产物环境合规

合规

GADSL/IMDS	Not Relevant
China RoHS	
EU ELV	Not Relevant
Low-Halogen Status	Low-Halogen per IEC 61249-2-21
REACH SVHC	Not Contained per D(2023)3788-DC (14 Jun 2023)
EU RoHS	Compliant per EU 2015/863

多部分产品合规性声明

- Eu RoHS
- REACH SVHC
- Low-Halogen

多部分行业合规性文件

- IPC 1752A Class C

- IPC 1752A Class D
- Molex Product Compliance Declaration
- IEC-62474
- chemSHERPA (xml)

欧盟 RoHS 合格证书

产品详情

常规

状态	活动
类别	Crimp Terminals
系列	6459
说明	KK 254 Crimp Terminal 6459, 22-30 AWG, Reel, Phosphor Bronze Selective Gold (Au)
应用	Signal, Wire-to-Board
产品系列	KK Interconnect Systems
产品名称	KK 254
UPC	800754227421

物理

性别	女
材料 - 金属	Phosphor Bronze
材料 - 接合部位电镀	金牌
净重	0.069/g
包装形式	Reel
最薄镀层 - 接合部位	0.381µm
终端界面类型	Crimp or Compression
导线绝缘直径	1.57mm max.
线径规格 (AWG)	22, 24, 26, 28, 30
线缆尺寸mm ²	不适用

进程

无铅	不适用
----	-----

可连接使用部件

描述	产品编号
KK 254 Single Row Crimp Housings	<u>2695</u>

施工工具

全局

描述	产品编号
Extraction Tool for KK 2.54mm Terminals, 22-30 AWG	<u>0011030022</u>
Terminator Die	<u>0011402265</u>
Insertion Tool for KK 2.54mm Terminals, 22-30 AWG	<u>0638120000</u>
Mini-Mac Applicator for KK and Cat Ear Terminals for 22-30 AWG Wire with Insulation Diameter 1.09-1.57mm and 22-28 AWG Wire with Insulation Diameter 1.20-1.70mm	<u>0638882000</u>
Mini-Mac Applicator for KK and Cat Ear Terminals for 22-30 AWG Wire with Insulation Diameter 0.96-1.20mm	<u>0638882100</u>

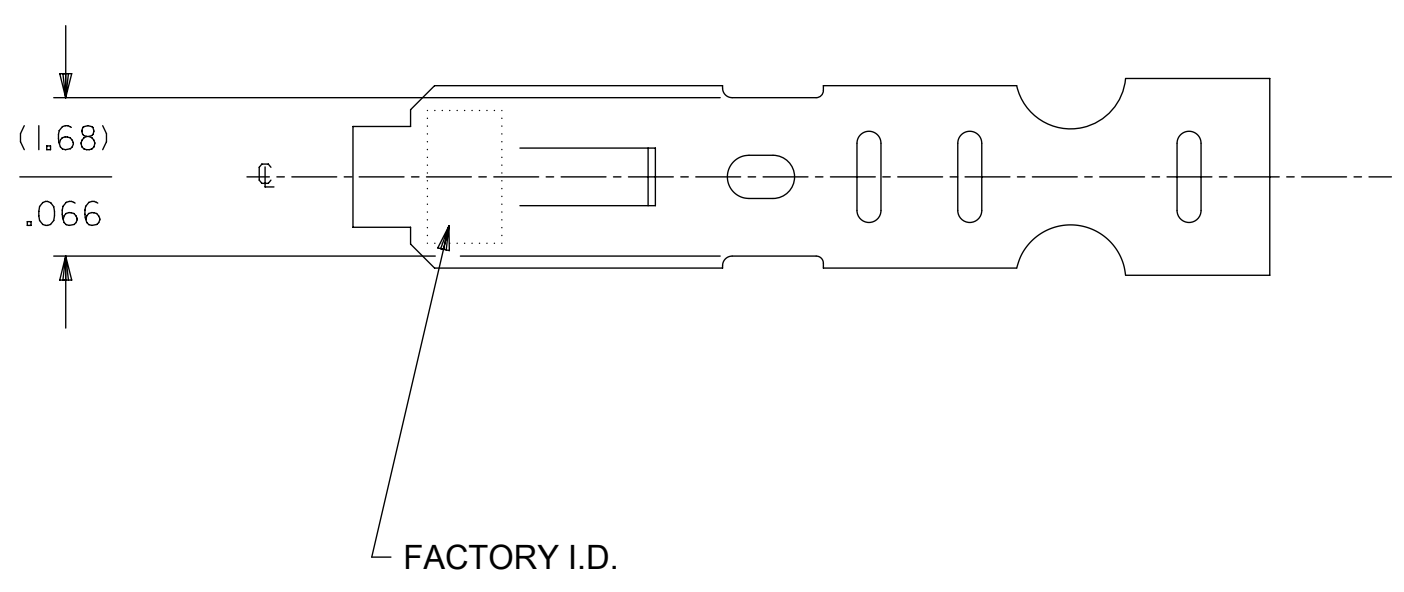
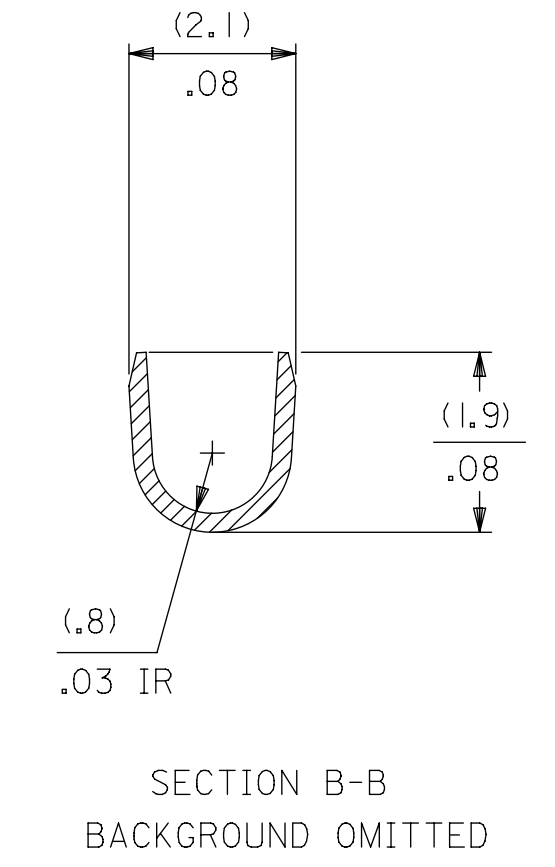
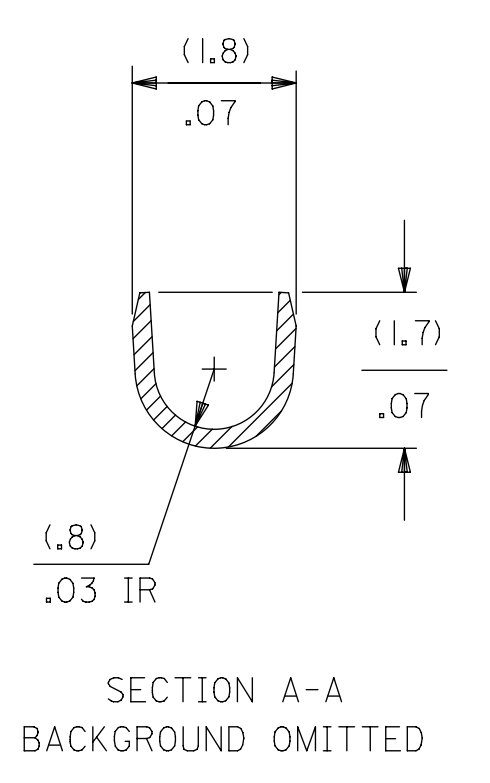
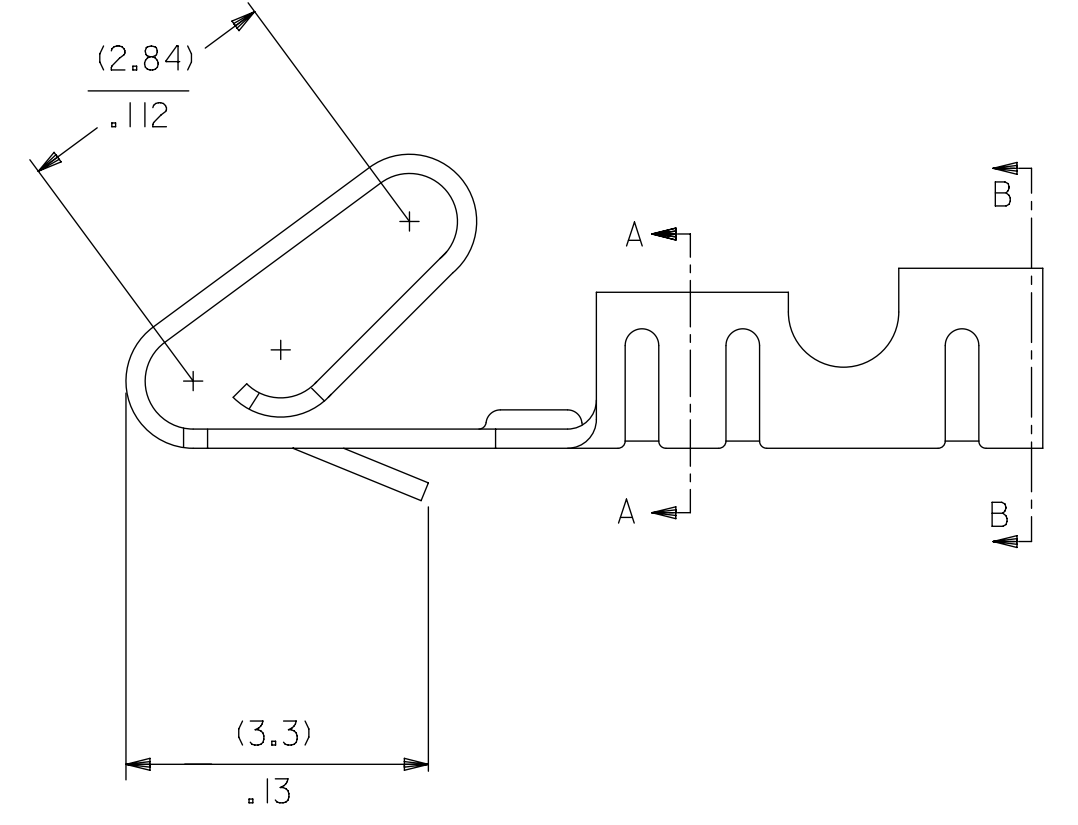
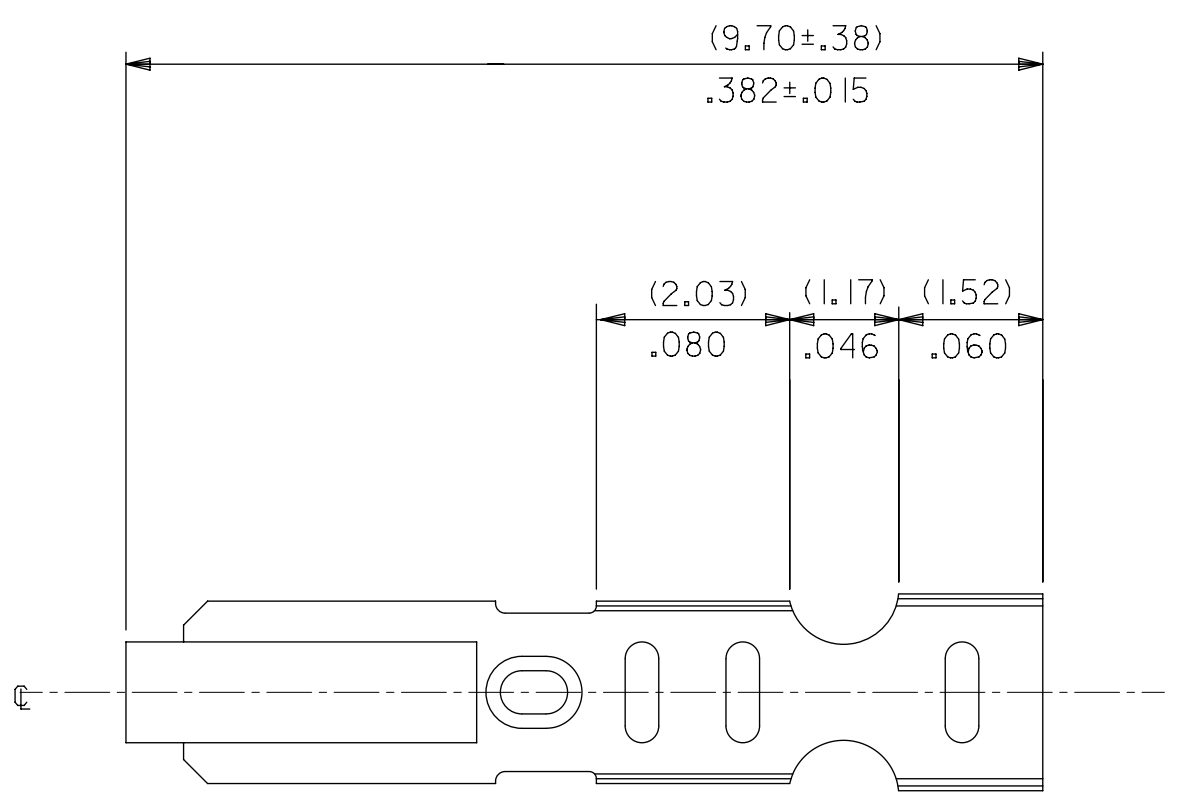
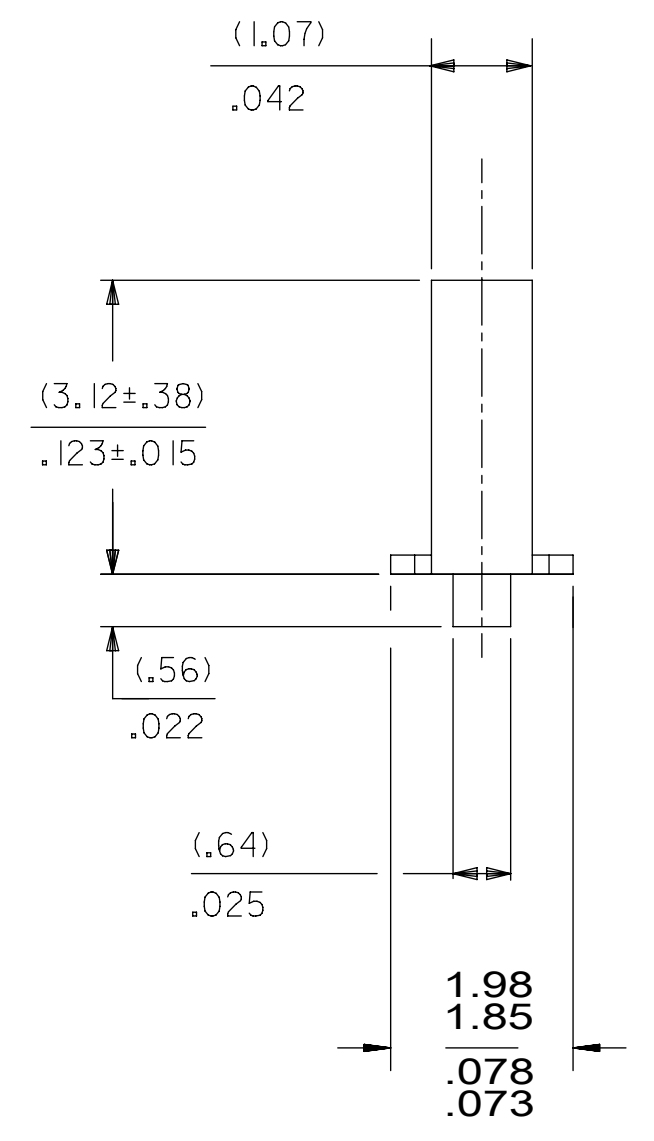
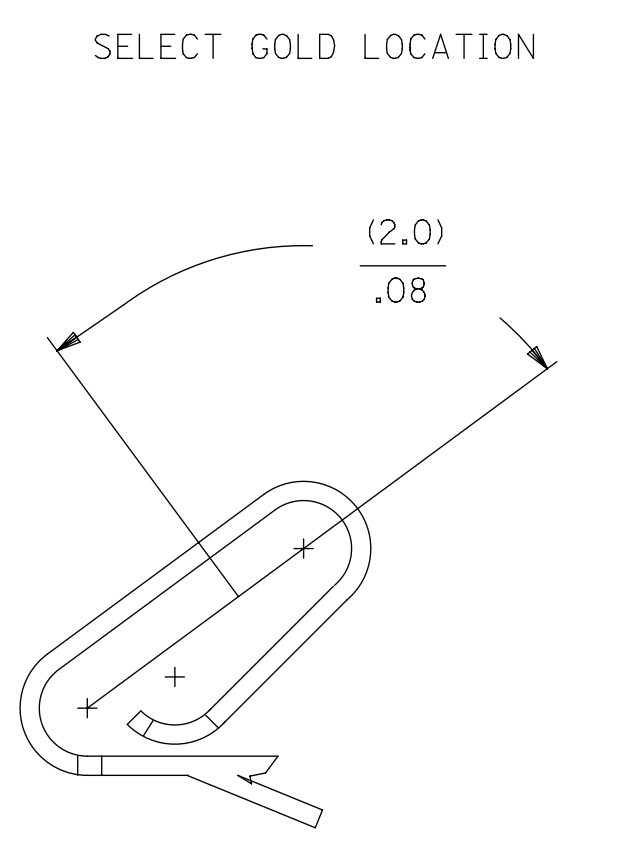
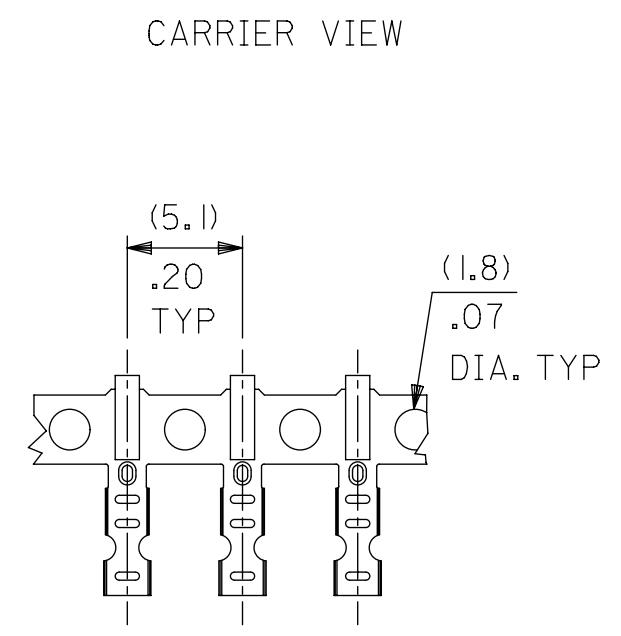

6459-(***)*
FORM
L=LOOSE
A=CHAIN PER DETAIL A
PLATING
SEE NOTE 2

- NOTES:
- MATERIAL:
(0.20)/.008 THICK PHOS BRONZE
 - FINISH:
222 - OVERALL MATTE TIN: (0.00254)/.000100 MIN. TIN OVER (0.00127)/.000050 MIN NICKEL
P909 - OVERALL HOT TIN DIP: (0.00254)/.000100 MIN.
231 - SELECT GOLD: (0.00127)/.000050 MIN. SELECT MATTE TIN: (0.00254)/.000100 MIN. OVERALL NICKEL UNDERPLATE: (0.00127)/.000050 MIN.
550 - SELECT GOLD: (0.00038)/.000015 MIN. OVERALL GOLD FLASH: (0.00005)/.000002 MIN. OVERALL NICKEL UNDERPLATE: (0.00076)/.000030 MIN.
555 - SELECT GOLD: (0.00038)/.000015 MIN. OVERALL NICKEL UNDERPLATE: (0.00076)/.000030
558 - SELECT GOLD: (0.00076)/.000030 MIN. OVERALL GOLD FLASH: (0.00005)/.000002 MIN. OVERALL NICKEL UNDERPLATE: (0.00127)/.000050 MIN.
561 - SELECT GOLD (0.00076)/.000030 MIN. OVERALL NICKEL UNDERPLATE: (0.00127)/.000050
 - PRODUCT SPEC: PS-10-07
 - PACKAGING SPECIFICATION: LOOSE TERMINALS: PER PK-2759-001 CHAIN FORM TERMINALS: PER PK-2759-002
 - CRIMP IS FOR 22-30 GA WIRE WITH (1.57)/.062 DIA INSULATION MAX.
 - INSERTION FORCE OF TERMINAL INTO (2.54)/.100 CENTERLINE CONNECTOR IS 2.5 LBS. MAX
 - TERMINAL RETENTION IN HOUSING IS 26.7N / 6LBS MIN. WHEN PULLED AT THE RATE OF (25.4MM) 1 INCH PER MINUTE.
 - DIMENSIONS GIVEN ACROSS CENTERLINES ARE SYMMETRICAL ABOUT THOSE CENTERLINES WITHIN HALF THE TOTAL TOLERANCE.
 - THIS PART CONFORMS TO CLASS B REQUIREMENTS OF COSMETIC SPECIFICATION PS-45499-002

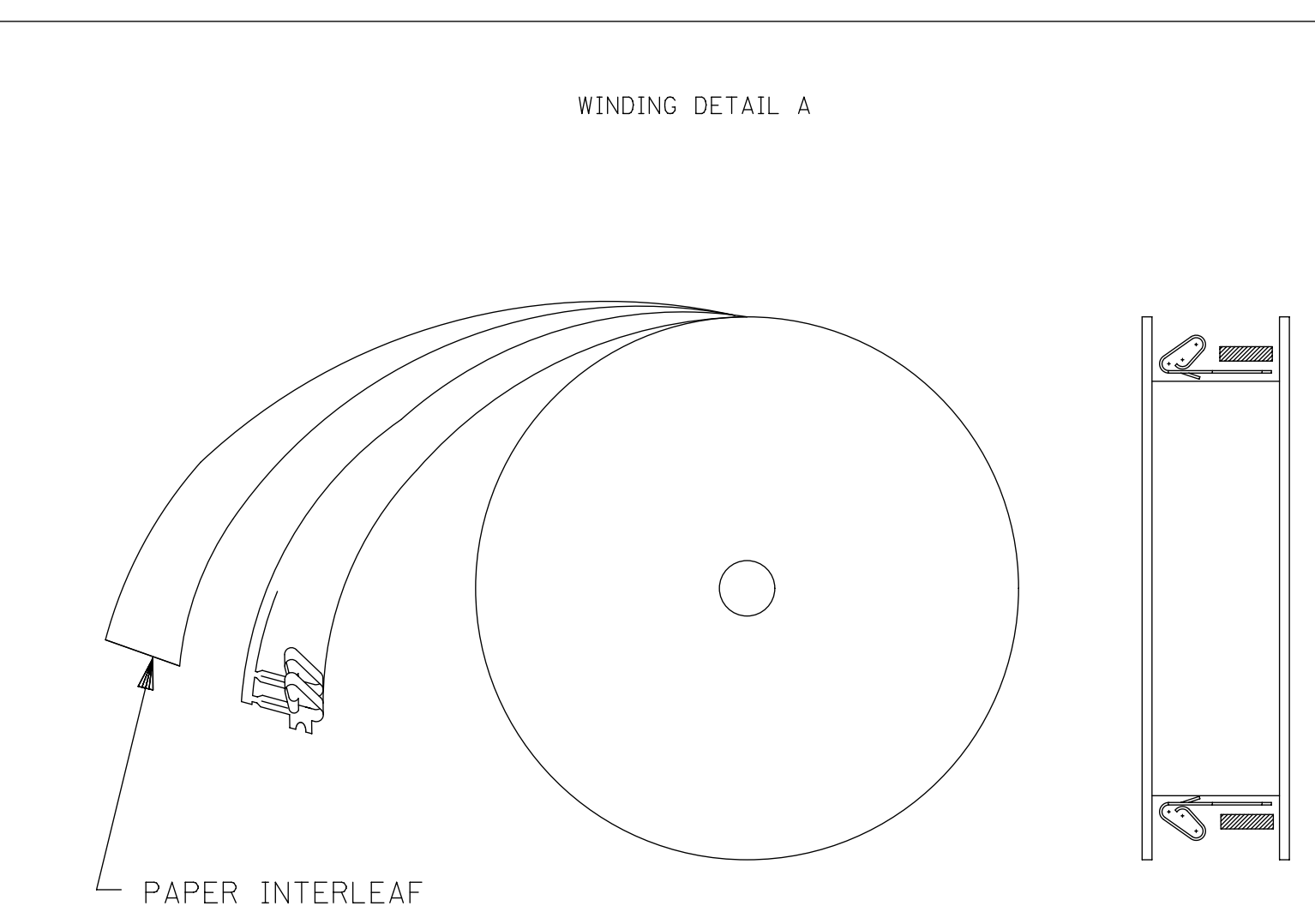

THIS DRAWING CONTAINS INFORMATION THAT IS PROPRIETARY TO MOLEX ELECTRONIC TECHNOLOGIES, LLC AND SHOULD NOT BE USED WITHOUT WRITTEN PERMISSION														
SYMBOLS	DIMENSION UNITS	SCALE	CURRENT REV DESC: NOTE 4 UPDATED											
	MM/IN	1:1	molex KK (2.54)/.100 CRIMP TERMINAL, 22-30 GA WIRE SAME AS 2759 EXCEPT MATL PRODUCT CUSTOMER DRAWING											
GENERAL TOLERANCES (UNLESS SPECIFIED)		MM								INCH	EC NO: 605479	DRWN: SS06	2018/09/07	DOCUMENT NUMBER
▽ = 0	4 PLACES ±	±	±	DRWN: ISHWARG	2018/10/05	SD-6459		PSD	001	H2				
▽ = 0	3 PLACES ±	±	± 0.01	APPR: ISHWARG	2018/10/05	INITIAL REVISION:		SHEET NUMBER						
▽ = 0	2 PLACES ±	0.25	± 0.014	DRWN: SAMIEC	1992/01/21	DRAFT WHERE APPLICABLE MUST REMAIN WITHIN DIMENSIONS		THIRD ANGLE PROJECTION		DRAWING	SERIES	MATERIAL NUMBER	CUSTOMER	SHEET NUMBER
▽ = 0	1 PLACE ±	0.36	±	APPR: FSMITH	2012/03/20	D-SIZE		6459	SEE CHART	GENERAL MARKET	1 OF 2			
⊠ = 0	ANGULAR TOL	±	0.5°											
■ = 0														
▽ = 0														

6459-(***)*

PART NO.

ENG. NO.

08-52-0101

6459-(P909)

08-52-0123

6459-(P909)L

08-65-0801

6459-(561)

6459-(561)L

08-52-0118

6459-(222)

6459-(222)L

08-65-0811

6459-(558)

08-65-0812

6459-(558)L

08-65-0815

6459-(555)

08-65-0816

6459-(555)L

08-65-0813

6459-(550)

08-65-0814





6459-(550)L

08-65-0817

6459-(231)

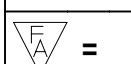
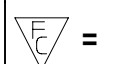
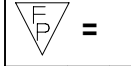
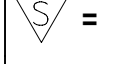
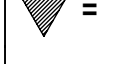
08-65-0818

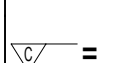
6459-(231)L

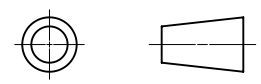
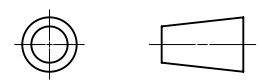
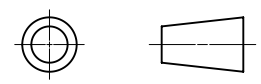
SYMBOLS  = 0  = 0  = 0  = 0  = 0  = 0  = 0  = 0  = 0	THIS DRAWING CONTAINS INFORMATION THAT IS PROPRIETARY TO MOLEX ELECTRONIC TECHNOLOGIES, LLC AND SHOULD NOT BE USED WITHOUT WRITTEN PERMISSION				CURRENT REV DESC: NOTE 4 UPDATED				 KK (2.54)/.100 CRIMP TERMINAL, 22-30 GA WIRE SAME AS 2759 EXCEPT MATL				
	DIMENSION UNITS		SCALE		EC NO: 605479 DRWN: SS06 2018/09/07 CHK'D: ISHWARG 2018/10/05 APPR: ISHWARG 2018/10/05 INITIAL REVISION: DRWN: SAMIEC 1992/01/21 APPR: FSMITH 2012/03/20								DOCUMENT NUMBER
	MM/IN		1:1						SD-6459		PSD	001	H2
	GENERAL TOLERANCES (UNLESS SPECIFIED)								MATERIAL NUMBER		CUSTOMER		SHEET NUMBER
			MM	INCH	SEE CHART				GENERAL MARKET		2 OF 2		
	4 PLACES ±		±	±	DRAFT WHERE APPLICABLE MUST REMAIN WITHIN DIMENSIONS				D-SIZE	6459			
	3 PLACES ±		±	0.01									
	2 PLACES ±		0.25	± 0.014									
	1 PLACE ±		0.36	±									
	0 PLACES ±		±	±									
ANGULAR TOL ±		0.5 °	±										