



产品编号 : [39000207](#)

Product Description : Mini-Fit Female Crimp Terminal, Tin (Sn) over Nickel (Ni), 18-24 AWG, Reel

系列号 : 5556

状态 : Active

Product Category : Crimp Terminals

工程编号 : 5556-SP

Packaging Alternative : [39000208](#) (Bag)



文件和资源

图纸

[图纸 039000207_sd.pdf](#)

[包装设计图 55560001-PK-000.pdf](#)

规格

[应用规格 55560001-AS-000.pdf](#)

[产品规格 55560002-PS-CH-000.pdf](#)

[产品规格 55560002-PS-ES-000.pdf](#)

[产品规格 55560002-PS-SK-000.pdf](#)

[产品规格 55560008-TS-000.pdf](#)

[产品规格 PS-5556-001-001.pdf](#)

[产品规格 PS-5556-002-001.pdf](#)

[测试摘要 55560010-TS-000.pdf](#)

[测试摘要 TS-5556-002-001.pdf](#)

产物环境合规

合规

GADSL/IMDS	Compliant with Exemption 44; 33
China RoHS	
EU ELV	Compliant per 2000/53/EC
Low-Halogen Status	Low-Halogen per IEC 61249-2-21
REACH SVHC	Not Contained per D(2023)8585-DC (23 Jan 2024)
EU RoHS	Compliant per EU 2015/863

多部分产品合规性声明

- Eu RoHS
- REACH SVHC
- Low-Halogen

多部分行业合规性文件

- IPC 1752A Class C
- IPC 1752A Class D
- Molex Product Compliance Declaration
- IEC-62474
- chemSHERPA (xml)

欧盟 RoHS 合格证书

产品详情

常规

状态	活动
类别	Crimp Terminals
系列	5556
说明	Mini-Fit Female Crimp Terminal, Tin (Sn) over Nickel (Ni), 18-24 AWG, Reel
应用	Power, Wire-to-Board, Wire-to-Wire
产品系列	Mini-Fit Family Power Connectors
产品名称	Mini-Fit
UPC	800754395991

电气

每触点最大电流	9.0A
电压 - 最大	600V

物理

耐用性(插拔次数) - 最多次数	30
性别	女
材料 - 金属	Brass
材料 - 接合部位电镀	Tin
材料 - 终端电镀	Tin
净重	0.130/g

包装形式	Reel
最薄镀层 - 接合部位	2.540μm
最薄镀层 - 端接	1.270μm
终端界面类型	Crimp or Compression
导线绝缘直径	1.30-3.10mm
线径规格 (AWG)	18, 20, 22, 24
线缆尺寸mm ²	不适用

可连接使用部件

描述	产品编号
Mini-Fit Jr. Receptacle Housings	<u>5557</u>
Mini-Fit BMI Dual Row Receptacle Housings	<u>44516</u>
Mini-Fit BMI Dual Row Receptacle Housings	<u>42474</u>
Mini-Fit BMI Dual Row Receptacle Housings	<u>43760</u>
Mini-Fit Jr. Dual Row Receptacle Housings	<u>46992</u>

施工工具

全局

描述	产品编号
Extraction Tool for Mini-Fit Jr. Terminals	<u>11030044</u>
FineAdjust Applicator for Mini-Fit Double Crimp Applications Using Two 22 AWG Wires	<u>2037026300</u>
PremiumGrade Hand Crimp Tool for Mini-Fit Jr. Male and Female Terminals, 18-24 AWG	<u>638190901</u>
FineAdjust Applicator for 18-20 AWG and 18-24 AWG Wires with Insulation Diameter 1.90-2.30mm	<u>639015600</u>
FineAdjust Applicator for Insulation OD 1.40-1.70mm - 18-24 AWG	<u>639023900</u>
FineAdjust Applicator for Insulation OD 2.50-2.95mm Optimized for 18 AWG Only	<u>639024800</u>

FineAdjust Applicator for Insulation OD 2.30-2.60mm - 18-24 AWG	<u>639024900</u>
FineAdjust Applicator for Insulation OD 2.50-2.95mm, 18-24 AWG	<u>639047800</u>
FineAdjust Applicator for Insulation OD 1.65-2.05mm, 18-24 AWG	<u>639048000</u>
T2 Terminator for Insulation OD 1.90-2.30mm - 18-24 AWG	<u>639115600</u>
T2 Terminator for insulation OD 1.40-1.70mm - 18-24 AWG	<u>639123900</u>
T2 Terminator for insulation OD 2.50-2.95mm optimized for 18 AWG only	<u>639124800</u>
T2 Terminator for insulation OD 2.30-2.60mm - 18-24 AWG	<u>639124900</u>
T2 Terminator for Mini-Fit Crimp Terminals, 18-24 AWG with Large Insulation ODs	<u>639147800</u>
T2 Terminator for Mini-Fit Crimp Terminals, 18-24 AWG with Smaller Insulation ODs	<u>639148000</u>

PART NO.	ENG. NO.	MAT'L.	PLATE	WIRE GAGE	DIM. "B"	DIM. "C"	DIM. "D"	DIM. "E"	DIM. "F"	DIM. "G"
39-00-0207	5556-SP	A BRASS	TIN	18-24 GA.	.142±.012 (3.60±0.30)	.177±.016 (4.50±0.40)	.035 ±.016 (0.90)±0.40	.075±.012 (1.90±0.30)	.091±.016 (2.30±0.40)	.020 (0.50)
39-00-0208	5556-SPL			22-28 GA.	.091±.012 (2.30±0.30)	.091±.016 (2.30±0.40)	.024 ±.016 (0.60)±0.40	.071±.012 (1.80±0.30)	.065±.016 (1.65±0.40)	.016 (0.40)
39-00-0209	5556-S2P			16 GA.	.142±.012 (3.60±0.30)	.177±.016 (4.50±0.40)	.035 ±.016 (0.90)±0.40	.091±.012 (2.30±0.30)	.106±.016 (2.70±0.40)	.024 (0.60)
39-00-0210	5556-S2PL				.142±.012 (3.60±0.30)	.177±.016 (4.50±0.40)	.035 ±.016 (0.90)±0.40	.091±.012 (2.30±0.30)	.106±.016 (2.70±0.40)	.024 (0.60)
39-00-0211	5556-S3P				.142±.012 (3.60±0.30)	.177±.016 (4.50±0.40)	.035 ±.016 (0.90)±0.40	.091±.012 (2.30±0.30)	.106±.016 (2.70±0.40)	.024 (0.60)
39-00-0212	5556-S3PL	B PHOS BRONZE	TIN	18-24 GA.	.142±.012 (3.60±0.30)	.177±.016 (4.50±0.40)	.035 ±.016 (0.90)±0.40	.075±.012 (1.90±0.30)	.091±.016 (2.30±0.40)	.020 (0.50)
39-00-0213	5556-PBSP			22-28 GA.	.091±.012 (2.30±0.30)	.091±.016 (2.30±0.40)	.024 ±.016 (0.60)±0.40	.071±.012 (1.80±0.30)	.065±.016 (1.65±0.40)	.016 (0.40)
39-00-0214	5556-PBSPL			16 GA.	.142±.012 (3.60±0.30)	.177±.016 (4.50±0.40)	.035 ±.016 (0.90)±0.40	.091±.012 (2.30±0.30)	.106±.016 (2.70±0.40)	.024 (0.60)
39-00-0215	5556-PBS2P				.142±.012 (3.60±0.30)	.177±.016 (4.50±0.40)	.035 ±.016 (0.90)±0.40	.091±.012 (2.30±0.30)	.106±.016 (2.70±0.40)	.024 (0.60)
39-00-0216	5556-PBS2PL				.142±.012 (3.60±0.30)	.177±.016 (4.50±0.40)	.035 ±.016 (0.90)±0.40	.091±.012 (2.30±0.30)	.106±.016 (2.70±0.40)	.024 (0.60)
39-00-0217	5556-PBS3P			.142±.012 (3.60±0.30)	.177±.016 (4.50±0.40)	.035 ±.016 (0.90)±0.40	.091±.012 (2.30±0.30)	.106±.016 (2.70±0.40)	.024 (0.60)	
39-00-0218	5556-PBS3PL									

LEGEND:

5556 - ** S * P *

BASE NO. _____

MATERIAL _____

BLANK= BRASS

PB= PHOS. BRONZE

S= TIN OVER NICKEL

PLATING & CRIMP SIZE COMB. _____

BLANK THRU 5

CHAIN OR LOOSE _____

BLANK= CHAIN

L= LOOSE

NOTES

- MATERIAL:
A= BRASS
B= PHOS. BRONZE
- FINISH:
TIN = .000100/(.00254) MIN BRIGHT TIN OVER .000050/(.00127)MIN. NICKEL
- PRODUCT SPECIFICATION: PS-5556-001, PS-5556-002, PS-5556-003.
- PACKAGING SPECIFICATION: PK-5556-001 FOR CHAIN TERMINALS
PK-5556-003 FOR LOOSE TERMINALS.
- MATES WITH: 5558, 5566, 5569, 30069, 30070, 42440, 42404, 43879, 43810, 44068.
- APPLICABLE HOUSINGS: 5557, 30067, 43760, 44516, OR 42474.
- THE NUMBER OF SERRATIONS TO BE ONE FOR WIRE RANGE #22-28.
- WHEN TERMINALS ARE INSTALLED IN THE HOUSING THE WIRES ARE TO BE DRESSED IN SUCH A MANNER TO ALLOW THE TERMINALS TO FLOAT FREELY IN THE POCKET.
- THIS TERMINAL IS DESIGNED FOR SINGLE WIRE CRIMPING.
- PART CONFORMS TO CLASS "B" REQUIREMENTS OF COSMETIC SPECIFICATION PS-45499-002.
- TEXT ON PART IS FOR REFERENCE ONLY. TEXT AND TEXT LOCATION MAY VARY DEPENDING ON PART NUMBER AND/OR TOOL.

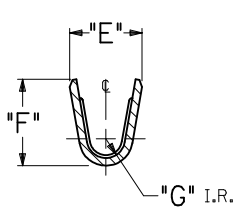
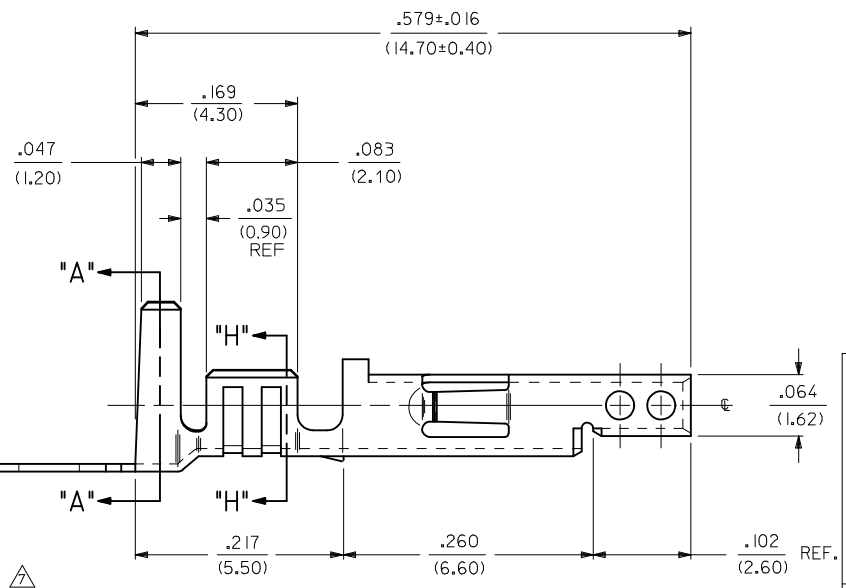
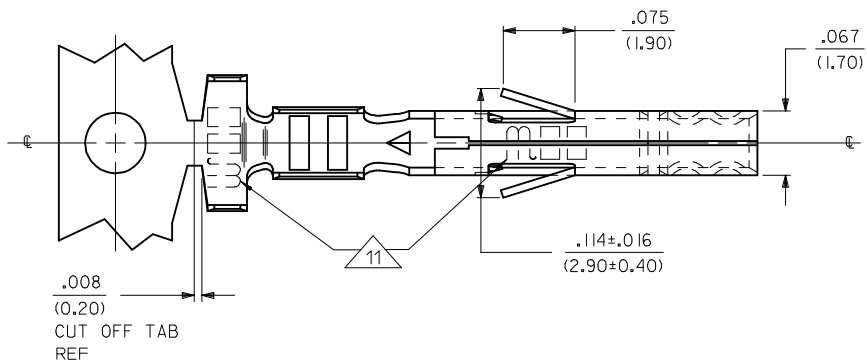

SECT. "H-H"

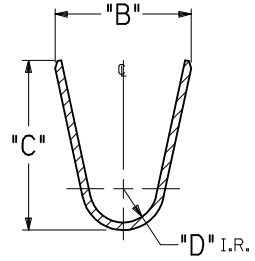

SECT. "A-A"

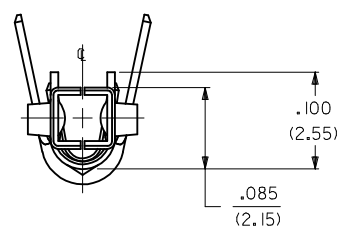

ADD NOTE 11 EC NO: UCP2017-2202 DRAWN: SLAFTER 2017/04/05 CHKD: J. BELL 2017/04/05 APPR: F. SMITH 2017/09/29 REV: F3	QUALITY SYMBOLS ∇=0 ∇=0 ∇=0	GENERAL TOLERANCES (UNLESS SPECIFIED) <table border="1"> <tr> <th></th> <th>mm</th> <th>INCH</th> </tr> <tr> <td>4 PLACES</td> <td>± .10</td> <td>± .004</td> </tr> <tr> <td>3 PLACES</td> <td>± .05</td> <td>± .002</td> </tr> <tr> <td>2 PLACES</td> <td>± 0.25</td> <td>± .010</td> </tr> <tr> <td>1 PLACE</td> <td>± 0.36</td> <td>± .014</td> </tr> <tr> <td>0 PLACE</td> <td>±</td> <td>±</td> </tr> </table>		mm	INCH	4 PLACES	± .10	± .004	3 PLACES	± .05	± .002	2 PLACES	± 0.25	± .010	1 PLACE	± 0.36	± .014	0 PLACE	±	±	DIMENSION STYLE IN/MM	SCALE DESIGN UNITS INCH	THIRD ANGLE PROJECTION
		mm	INCH																				
	4 PLACES	± .10	± .004																				
3 PLACES	± .05	± .002																					
2 PLACES	± 0.25	± .010																					
1 PLACE	± 0.36	± .014																					
0 PLACE	±	±																					
MATERIAL NO. SEE CHART	DOCUMENT NO. SD-5556-SP*	SHEET NO. 1 OF 1	mini fit jr overall BRIGHT TIN OVER NICKEL FEMALE CRIMP TERMINAL molex																				
DRAFT WHERE APPLICABLE MUST REMAIN WITHIN DIMENSIONS																							

PART NO.	ENG. NO.	MAT'L.	PLATE	WIRE GAGE	DIM. "B"	DIM. "C"	DIM. "D"	DIM. "E"	DIM. "F"	DIM. "G"
39-00-0207	5556-SP	A BRASS	TIN	18-24 GA.	.142±.012 (3.60±0.30)	.177±.016 (4.50±0.40)	.035 ±.016 (0.90)±0.40	.075±.012 (1.90±0.30)	.091±.016 (2.30±0.40)	.020 (0.50)
39-00-0208	5556-SPL			22-28 GA.	.091±.012 (2.30±0.30)	.091±.016 (2.30±0.40)	.024 ±.016 (0.60)±0.40	.071±.012 (1.80±0.30)	.065±.016 (1.65±0.40)	.016 (0.40)
39-00-0209	5556-S2P			16 GA.	.142±.012 (3.60±0.30)	.177±.016 (4.50±0.40)	.035 ±.016 (0.90)±0.40	.091±.012 (2.30±0.30)	.106±.016 (2.70±0.40)	.024 (0.60)
39-00-0210	5556-S2PL				.142±.012 (3.60±0.30)	.177±.016 (4.50±0.40)	.035 ±.016 (0.90)±0.40	.091±.012 (2.30±0.30)	.106±.016 (2.70±0.40)	.024 (0.60)
39-00-0211	5556-S3P				.142±.012 (3.60±0.30)	.177±.016 (4.50±0.40)	.035 ±.016 (0.90)±0.40	.091±.012 (2.30±0.30)	.106±.016 (2.70±0.40)	.024 (0.60)
39-00-0212	5556-S3PL	B PHOS BRONZE	TIN	18-24 GA.	.142±.012 (3.60±0.30)	.177±.016 (4.50±0.40)	.035 ±.016 (0.90)±0.40	.075±.012 (1.90±0.30)	.091±.016 (2.30±0.40)	.020 (0.50)
39-00-0213	5556-PBSP			22-28 GA.	.091±.012 (2.30±0.30)	.091±.016 (2.30±0.40)	.024 ±.016 (0.60)±0.40	.071±.012 (1.80±0.30)	.065±.016 (1.65±0.40)	.016 (0.40)
39-00-0214	5556-PBSPL			16 GA.	.142±.012 (3.60±0.30)	.177±.016 (4.50±0.40)	.035 ±.016 (0.90)±0.40	.091±.012 (2.30±0.30)	.106±.016 (2.70±0.40)	.024 (0.60)
39-00-0215	5556-PBS2P				.142±.012 (3.60±0.30)	.177±.016 (4.50±0.40)	.035 ±.016 (0.90)±0.40	.091±.012 (2.30±0.30)	.106±.016 (2.70±0.40)	.024 (0.60)
39-00-0216	5556-PBS2PL				.142±.012 (3.60±0.30)	.177±.016 (4.50±0.40)	.035 ±.016 (0.90)±0.40	.091±.012 (2.30±0.30)	.106±.016 (2.70±0.40)	.024 (0.60)
39-00-0217	5556-PBS3P			.142±.012 (3.60±0.30)	.177±.016 (4.50±0.40)	.035 ±.016 (0.90)±0.40	.091±.012 (2.30±0.30)	.106±.016 (2.70±0.40)	.024 (0.60)	
39-00-0218	5556-PBS3PL									

LEGEND:

5556 - ** S * P *

BASE NO. _____
MATERIAL _____
BLANK= BRASS
PB= PHOS. BRONZE
S= TIN OVER NICKEL
PLATING & CRIMP SIZE COMB. _____
BLANK THRU 5

CHAIN OR LOOSE _____
BLANK= CHAIN
L= LOOSE

NOTES

- MATERIAL:
A= BRASS
B= PHOS. BRONZE
- FINISH:
TIN = .000100/(.00254) MIN BRIGHT TIN OVER .000050/(.00127)MIN. NICKEL
- PRODUCT SPECIFICATION: PS-5556-001, PS-5556-002, PS-5556-003.
- PACKAGING SPECIFICATION: PK-5556-001 FOR CHAIN TERMINALS
PK-5556-003 FOR LOOSE TERMINALS.
- MATES WITH: 5558, 5566, 5569, 30069, 30070, 42440, 42404, 43879, 43810, 44068.
- APPLICABLE HOUSINGS: 5557, 30067, 43760, 44516, OR 42474.
- THE NUMBER OF SERRATIONS TO BE ONE FOR WIRE RANGE #22-28.
- WHEN TERMINALS ARE INSTALLED IN THE HOUSING THE WIRES ARE TO BE DRESSED IN SUCH A MANNER TO ALLOW THE TERMINALS TO FLOAT FREELY IN THE POCKET.
- THIS TERMINAL IS DESIGNED FOR SINGLE WIRE CRIMPING.
- PART CONFORMS TO CLASS "B" REQUIREMENTS OF COSMETIC SPECIFICATION PS-45499-002.
- TEXT ON PART IS FOR REFERENCE ONLY. TEXT AND TEXT LOCATION MAY VARY DEPENDING ON PART NUMBER AND/OR TOOL.

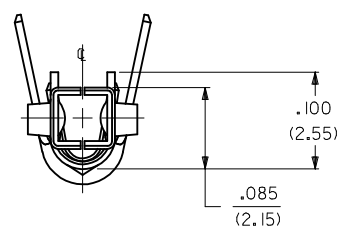
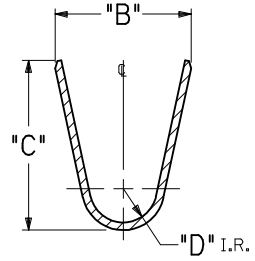
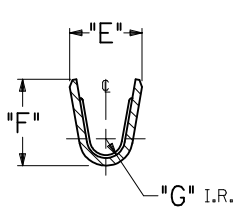
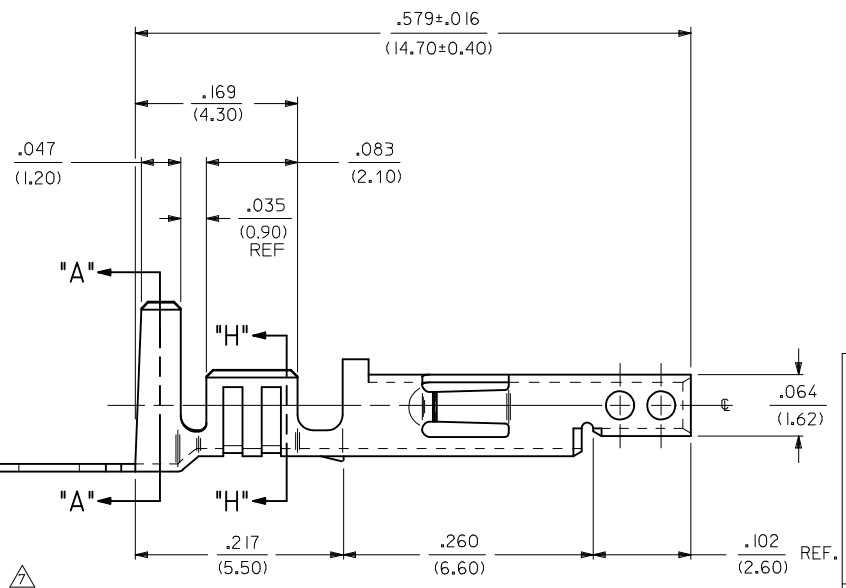
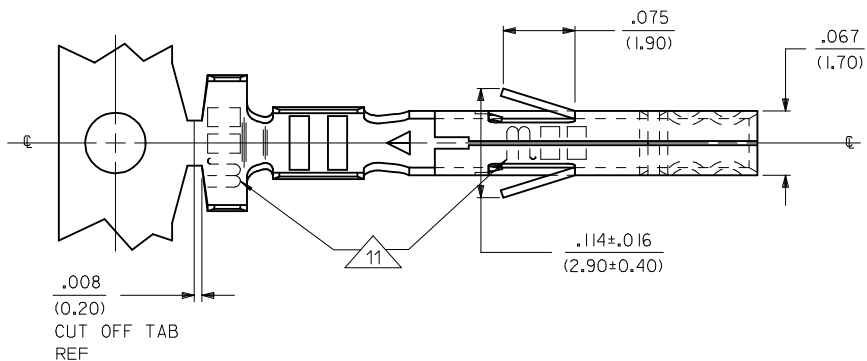

ADD NOTE 11 EC NO: UCP2017-2202 DRAWN: SLAFTER 2017/04/05 CHKD: J.BELL 2017/04/05 APPR: F.S.MITH 2017/09/29	QUALITY SYMBOLS ∇=0 ∇=0 ∇=0	GENERAL TOLERANCES (UNLESS SPECIFIED)		DIMENSION STYLE IN/MM		SCALE INCH	DESIGN UNITS INCH	THIRD ANGLE PROJECTION	
		mm	INCH	DRAWN BY	DATE	TITLE MINI FIT JR OVERALL BRIGHT TIN OVER NICKEL FEMALE CRIMP TERMINAL			
		4 PLACES ± --- ± ---	3 PLACES ± --- ± .010	2 PLACES ± 0.25 ± .014	1 PLACE ± 0.36 ± ---	0 PLACE ± ±	APPROVED BY RAS	DATE 5/17/1990	molex
ANGULAR ±1/2°		MATERIAL NO. SEE CHART		DOCUMENT NO. SD-5556-SP*		SHEET NO. 1 OF 1			
DRAFT WHERE APPLICABLE MUST REMAIN WITHIN DIMENSIONS									
THIS DRAWING CONTAINS INFORMATION THAT IS PROPRIETARY TO MOLEX INCORPORATED AND SHOULD NOT BE USED WITHOUT WRITTEN PERMISSION									