

产品编号 : [430451812](#)

**Product Description** : Micro-Fit 3.0 Vertical Header, 3.00mm Pitch, Dual Row, 18 Circuits, with PCB Polarizing Peg, Tin, Glow-Wire Capable, Black

系列号 : 43045

状态 : Active

**Product Category** : PCB Headers and Receptacles

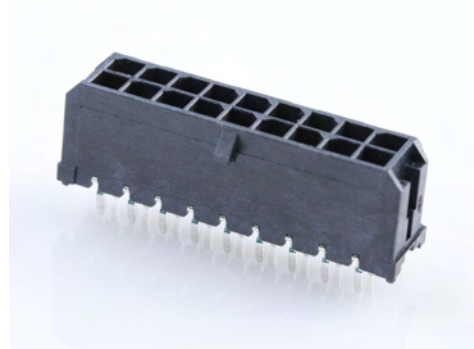

## 文件和资源

### 图纸

[图纸 430451812\\_sd.pdf](#)

[包装设计图 PK-70873-0314-001.pdf](#)

### 3D 模型和设计文件

[3D模型 430451812\\_stp.zip](#)

[符号足迹数据 SYM-43045-1812-001.zip](#)

[符号足迹数据 SYM-43045-181X-001.zip](#)

### 规格

[产品规格 430450001-PS-K0-000.pdf](#)

[产品规格 430450001-PS-SP-000.pdf](#)

[产品规格 PS-43045-001.pdf](#)

[测试摘要 430450004-TS-000.pdf](#)

[测试摘要 TS-43045-001-001.pdf](#)

[测试摘要 TS-46235-001-001.pdf](#)

## 产物环境合规

### 合规

|                    |   |
|--------------------|---|
| GADSL/IMDS         | Compliant with Exemption 44; 33   |
| China RoHS         |  |
| EU ELV             | Not Relevant  |
| Low-Halogen Status | Low-Halogen per IEC 61249-2-21  |
| REACH SVHC         | Not Contained per D(2023)3788-DC (14 Jun 2023)  |
| EU RoHS            | Compliant per EU 2015/863   |

## 多部分产品合规性声明

- Eu RoHS
- REACH SVHC
- Low-Halogen

## 多部分行业合规性文件

- IPC 1752A Class C
- IPC 1752A Class D
- Molex Product Compliance Declaration
- IEC-62474
- chemSHERPA (xml)

## 欧盟 RoHS 合格证书

---

## 产品详情

### 常规

|    |  |
|----|--|
| 状态 | 活动   |
| 类别 | PCB Headers and Receptacles  |
| 系列 | 43045  |
| 说明 | Micro-Fit 3.0 Vertical Header,<br>3.00mm Pitch, Dual Row, 18<br>Circuits, with PCB Polarizing<br>Peg, Tin, Glow-Wire Capable,<br>Black |
| 应用 | Power, Wire-to-Board   |

|      |  |
|------|--|
| 个评论  | <p>High Temperature, Square Pin, Offset Through Hole Mounting, Solder Type; This Molex product is manufactured from material that has the following ratings, tested by independent agencies:</p> <p>a) A Glow Wire Ignition Temperature (GWIT) of at least 775 deg C per IEC 60695-2-13. b) A Glow Wire Flammability Index (GWFI) above 850 deg C per IEC 60695-2-12 and hence complies with the requirements set out in the International Standard IEC 60335-1 5th edition - household and similar electrical appliances - safety, section 30 Resistance to heat and fire. The customers using this product must determine its suitability for use in their particular application through testing or other acceptable means as described in end-product glow-wire flammability test standard IEC 60695-2-11 and any applicable product end-use standard(s). If it is determined during the customer's evaluation of suitability, that higher performance is required, please contact Molex for possible product options.</p> |
| 元件类型 | PCB Header   |
| 产品系列 | Micro-Fit Connector System   |
| 产品名称 | Micro-Fit 3.0  |
| UPC  | 800754374774   |

#### 机构

|     |         |
|-----|---------|
| CSA | LR19980 |
| UL  | E29179  |

#### 电气

|         |      |
|---------|------|
| 每触点最大电流 | 8.5A |
| 电压 - 最大 | 600V |

#### 物理

|           |    |
|-----------|----|
| 断开        | 否  |
| 回路数 (已载入) | 18 |
| 电路数 (最多)  | 18 |

|                  |                                |
|------------------|--------------------------------|
| 颜色-树脂            | 黑色                             |
| 耐用性(插拔次数) - 最多次数 | 30                             |
| 阻燃性              | 94V-0                          |
| 符合灼热丝规范          | 是                              |
| 插配长度             | 17.64mm                        |
| 材料 - 金属          | Brass                          |
| 材料 - 接合部位电镀      | Tin                            |
| 材料 - 终端电镀        | Tin                            |
| 材料 - 树脂          | High Temperature Thermoplastic |
| 净重               | 2.443/g                        |
| 行数               | 2                              |
| 方向               | 垂直                             |
| 包装形式             | Tray                           |
| PCB 定位器          | 是                              |
| PCB 保持力          | 是                              |
| 推荐的 PCB 厚度       | 1.60mm                         |
| 间距 - 插配接口        | 3.00mm                         |
| 最薄镀层 - 接合部位      | 0.254µm                        |
| PCB 极性           | 是                              |
| 有护墙的             | Fully                          |
| 可堆叠的             | 否                              |
| 运行温度范围           | -40° to +105° C                |
| 终端界面类型           | Through Hole - Kinked Pin      |

## 进程

|        |          |
|--------|----------|
| 最长持续时间 | 30       |
| 无铅     | SMC&WAVE |
| 最大周期   | 3        |
| 最高温度   | 260      |

## 可配插/可连接使用的产品

### 可配插部件

| 描述 | 产品编号 |
|----|------|
|----|------|

|  |               |
|--|---------------|
| Micro-Fit 3.0 Dual Row Receptacle Housings | <u>43025</u>  |
| Micro-Fit TPA Receptacle Housings          | <u>172952</u> |

---

This document was generated on Jan 02, 2024

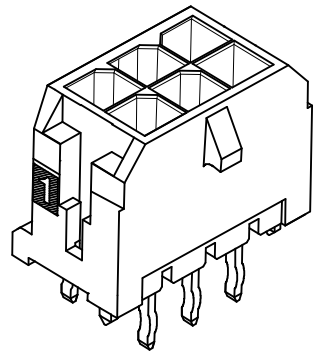
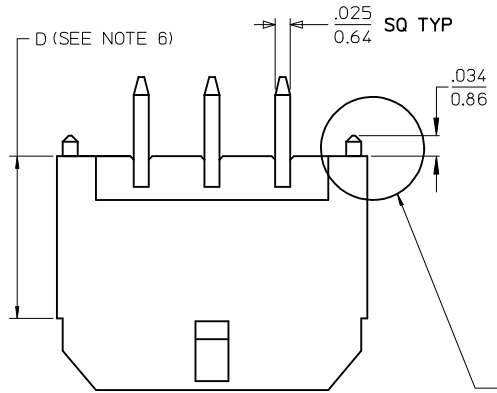

NOTE : (2) POLARIZATION PEGS ARE SHOWN, HOWEVER, ASSEMBLIES MAY BE MANUFACTURED WITH (1) PEG ONLY.

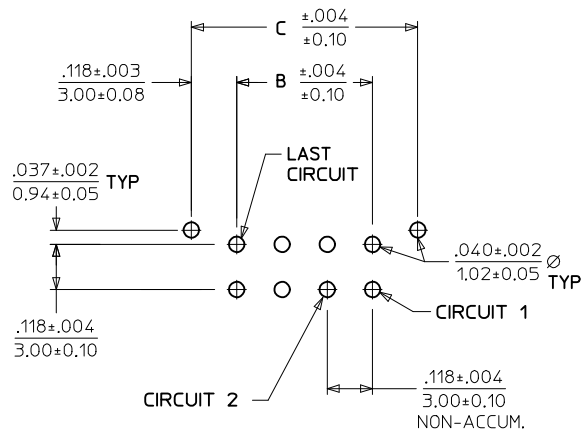

PCB LAYOUT: COMPONENT SIDE  
RECOMMEND PCB THICKNESS: .062/1.57

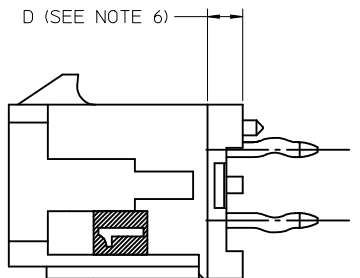
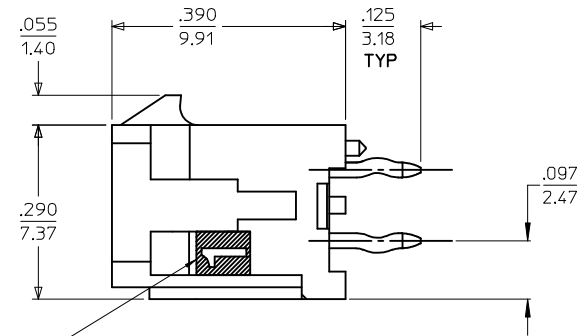
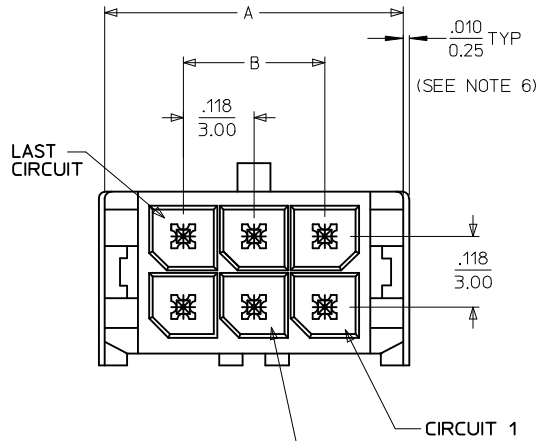

- NOTES:**
- HOUSING MATERIAL: GLASS FILLED LIQUID CRYSTAL POLYMER, UL94V-0, COLOR: BLACK  
TERMINAL MATERIAL: BRASS ALLOY
  - FINISH: A = .000060/(0.00152) MIN. REFLOWED MATTE TIN OVER .000050/(0.00127) MIN. NICKEL PLATE. (FINISH IS BRIGHT IN APPEARANCE. THICKNESS AS APPLIED PRIOR TO REFLOW)  
B = .000015/(0.00038) MIN. SELECT GOLD IN CONTACT AREA, .000100/(0.00254) MIN. SELECT MATTE TIN ON SOLDER TAILS, BOTH OVER .000050/(0.00127) MIN. NICKEL PLATE.  
C = .000030/(0.00076) MIN. SELECT GOLD IN CONTACT AREA, .000100/(0.00254) MIN. SELECT MATTE TIN ON SOLDER TAILS, BOTH OVER .000050/(0.00127) MIN. NICKEL PLATE.  
D = .000100/(0.00254) MIN. MATTE TIN OVER .000050/(0.00127) MIN. NICKEL PLATE.
  - PRODUCT SPECIFICATION: PS-43045
  - TRAY PACKAGED: SEE MOLEX DRAWING PK-70873-0314
  - MATES WITH MICRO FIT (3.0) RECEPTACLE SERIES 43025
  - CIRCUIT SIZES 2-6: "D" IS 0.265/6.74 FOR .010/0.25 STEP. CIRCUIT SIZES 8-24: "D" IS 0.063/1.60 FOR .010/0.25 STEP.
  - THIS PART CONFORMS TO CLASS B REQUIREMENTS OF COSMETIC SPECIFICATION PS-45499-002.

| CKTS | FINISH A   | FINISH B   | FINISH C   | FINISH D   |
|------|------------|------------|------------|------------|
| 02   | 43045-0212 | 43045-0213 | 43045-0214 | 43045-0311 |
| 04   | 43045-0412 | 43045-0413 | 43045-0414 | 43045-0511 |
| 06   | 43045-0612 | 43045-0613 | 43045-0614 | 43045-0711 |
| 08   | 43045-0812 | 43045-0813 | 43045-0814 | 43045-0911 |
| 10   | 43045-1012 | 43045-1013 | 43045-1014 | 43045-1111 |
| 12   | 43045-1212 | 43045-1213 | 43045-1214 | 43045-1311 |
| 14   | 43045-1412 | 43045-1413 | 43045-1414 | 43045-1511 |
| 16   | 43045-1612 | 43045-1613 | 43045-1614 | 43045-1711 |
| 18   | 43045-1812 | 43045-1813 | 43045-1814 | 43045-1911 |
| 20   | 43045-2012 | 43045-2013 | 43045-2014 | 43045-2111 |
| 22   | 43045-2212 | 43045-2213 | 43045-2214 | 43045-2311 |
| 24   | 43045-2412 | 43045-2413 | 43045-2414 | 43045-2511 |

| <b>FINISH A &amp; D</b><br>EC NO: UCP2016-4586<br>DRAWN: JDOX<br>CHKD: SSOUSEK<br>APPR: FSM/TH<br>2015/12/10<br>2015/12/10<br>2016/08/23 | QUALITY SYMBOLS<br>∇=0<br>∇=0<br>∇=0 | GENERAL TOLERANCES (UNLESS SPECIFIED)<br><table border="1"> <tr> <th></th> <th>mm</th> <th>INCH</th> </tr> <tr> <td>4 PLACES</td> <td>± .010</td> <td>± .0004</td> </tr> <tr> <td>3 PLACES</td> <td>± .010</td> <td>± .0004</td> </tr> <tr> <td>2 PLACES</td> <td>± 0.25</td> <td>± .010</td> </tr> <tr> <td>1 PLACE</td> <td>± 0.36</td> <td>± .014</td> </tr> <tr> <td>0 PLACE</td> <td>± .---</td> <td>± .---</td> </tr> </table> |  | mm                                  | INCH | 4 PLACES | ± .010 | ± .0004 | 3 PLACES | ± .010 | ± .0004 | 2 PLACES | ± 0.25 | ± .010 | 1 PLACE | ± 0.36 | ± .014 | 0 PLACE | ± .--- | ± .--- | DIMENSION STYLE<br>IN/MM<br>DRAWN BY: SAMIEC<br>DATE: 2000/03/15<br>CHECKED BY: SSOUSEK<br>DATE: 2016/06/01<br>APPROVED BY: FSM/TH<br>DATE: 2016/08/23 | SCALE: ---<br>DESIGN UNITS: METRIC<br>THIRD ANGLE PROJECTION |
|--|--------------------------------------|--|--|-------------------------------------|------|----------|--------|---------|----------|--------|---------|----------|--------|--------|---------|--------|--------|---------|--------|--------|--|--|
|  |                                      |  | mm   | INCH                                |      |          |        |         |          |        |         |          |        |        |         |        |        |         |        |        |  |  |
|  |                                      | 4 PLACES   | ± .010   | ± .0004                             |      |          |        |         |          |        |         |          |        |        |         |        |        |         |        |        |  |  |
|  |                                      | 3 PLACES   | ± .010   | ± .0004                             |      |          |        |         |          |        |         |          |        |        |         |        |        |         |        |        |  |  |
| 2 PLACES   | ± 0.25                               | ± .010   |  |                                     |      |          |        |         |          |        |         |          |        |        |         |        |        |         |        |        |  |  |
| 1 PLACE  | ± 0.36                               | ± .014   |  |                                     |      |          |        |         |          |        |         |          |        |        |         |        |        |         |        |        |  |  |
| 0 PLACE  | ± .---                               | ± .---   |  |                                     |      |          |        |         |          |        |         |          |        |        |         |        |        |         |        |        |  |  |
| DRAFT WHERE APPLICABLE MUST REMAIN WITHIN DIMENSIONS   |                                      | MATERIAL NO.<br><b>SEE CHART</b>   | TITLE<br><b>MICRO FIT (3.0) DUAL ROW VERTICAL THRU HOLE HEADER ASS'Y</b><br><b>molex</b> | DOCUMENT NO.<br><b>SD-43045-005</b> |      |          |        |         |          |        |         |          |        |        |         |        |        |         |        |        |  |  |
| FINISH A & D<br>G1   |                                      | MATERIAL NO.<br><b>SEE CHART</b>   |  | SHEET NO.<br><b>1 OF 1</b>          |      |          |        |         |          |        |         |          |        |        |         |        |        |         |        |        |  |  |
| THIS DRAWING CONTAINS INFORMATION THAT IS PROPRIETARY TO MOLEX INCORPORATED AND SHOULD NOT BE USED WITHOUT WRITTEN PERMISSION            |                                      |  |  |                                     |      |          |        |         |          |        |         |          |        |        |         |        |        |         |        |        |  |  |

| CKTS | A              | B              | C              |
|------|----------------|----------------|----------------|
| 02   | .262<br>6.65   | NA             | .236<br>6.00   |
| 04   | .380<br>9.65   | .118<br>3.00   | .354<br>9.00   |
| 06   | .498<br>12.65  | .236<br>6.00   | .472<br>12.00  |
| 08   | .616<br>15.65  | .354<br>9.00   | .591<br>15.00  |
| 10   | .734<br>18.65  | .472<br>12.00  | .709<br>18.00  |
| 12   | .852<br>21.65  | .591<br>15.00  | .827<br>21.00  |
| 14   | .970<br>24.65  | .709<br>18.00  | .945<br>24.00  |
| 16   | 1.088<br>27.65 | .827<br>21.00  | 1.063<br>27.00 |
| 18   | 1.206<br>30.65 | .945<br>24.00  | 1.181<br>30.00 |
| 20   | 1.325<br>33.65 | 1.063<br>27.00 | 1.299<br>33.00 |
| 22   | 1.443<br>36.65 | 1.181<br>30.00 | 1.417<br>36.00 |
| 24   | 1.561<br>39.65 | 1.299<br>33.00 | 1.535<br>39.00 |

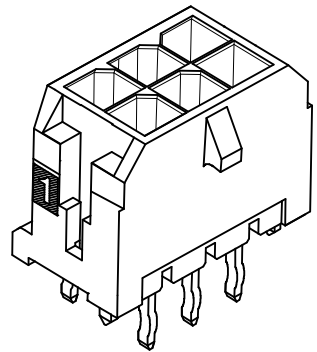
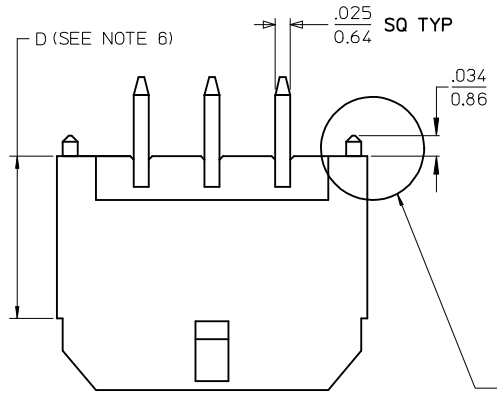

NOTE : (2) POLARIZATION PEGS ARE SHOWN, HOWEVER, ASSEMBLIES MAY BE MANUFACTURED WITH (1) PEG ONLY.

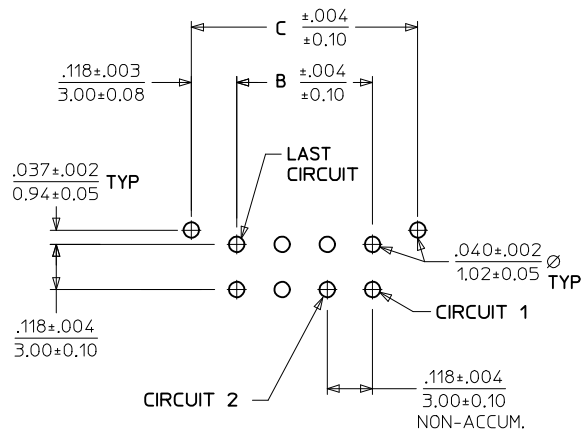

PCB LAYOUT: COMPONENT SIDE  
RECOMMEND PCB THICKNESS: .062/1.57

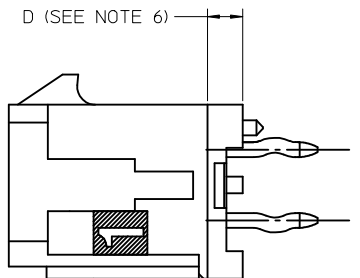
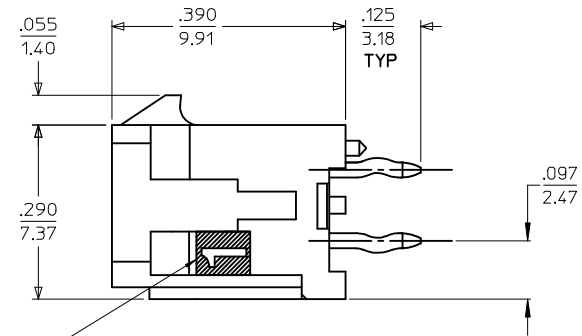
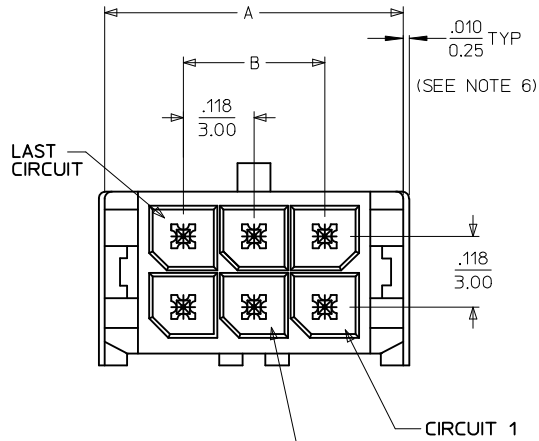

- NOTES:**
- HOUSING MATERIAL: GLASS FILLED LIQUID CRYSTAL POLYMER, UL94V-0, COLOR: BLACK  
TERMINAL MATERIAL: BRASS ALLOY
  - FINISH: A = .000060/(0.00152) MIN. REFLOWED MATTE TIN OVER .000050/(0.00127) MIN. NICKEL PLATE. (FINISH IS BRIGHT IN APPEARANCE. THICKNESS AS APPLIED PRIOR TO REFLOW)  
B = .000015/(0.00038) MIN. SELECT GOLD IN CONTACT AREA, .000100/(0.00254) MIN. SELECT MATTE TIN ON SOLDER TAILS, BOTH OVER .000050/(0.00127) MIN. NICKEL PLATE.  
C = .000030/(0.00076) MIN. SELECT GOLD IN CONTACT AREA, .000100/(0.00254) MIN. SELECT MATTE TIN ON SOLDER TAILS, BOTH OVER .000050/(0.00127) MIN. NICKEL PLATE.  
D = .000100/(0.00254) MIN. MATTE TIN OVER .000050/(0.00127) MIN. NICKEL PLATE.
  - PRODUCT SPECIFICATION: PS-43045
  - TRAY PACKAGED: SEE MOLEX DRAWING PK-70873-0314
  - MATES WITH MICRO FIT (3.0) RECEPTACLE SERIES 43025
  - CIRCUIT SIZES 2-6: "D" IS 0.265/6.74 FOR .010/0.25 STEP. CIRCUIT SIZES 8-24: "D" IS 0.063/1.60 FOR .010/0.25 STEP.
  - THIS PART CONFORMS TO CLASS B REQUIREMENTS OF COSMETIC SPECIFICATION PS-45499-002.

| CKTS | FINISH A   | FINISH B   | FINISH C   | FINISH D   |
|------|------------|------------|------------|------------|
| 02   | 43045-0212 | 43045-0213 | 43045-0214 | 43045-0311 |
| 04   | 43045-0412 | 43045-0413 | 43045-0414 | 43045-0511 |
| 06   | 43045-0612 | 43045-0613 | 43045-0614 | 43045-0711 |
| 08   | 43045-0812 | 43045-0813 | 43045-0814 | 43045-0911 |
| 10   | 43045-1012 | 43045-1013 | 43045-1014 | 43045-1111 |
| 12   | 43045-1212 | 43045-1213 | 43045-1214 | 43045-1311 |
| 14   | 43045-1412 | 43045-1413 | 43045-1414 | 43045-1511 |
| 16   | 43045-1612 | 43045-1613 | 43045-1614 | 43045-1711 |
| 18   | 43045-1812 | 43045-1813 | 43045-1814 | 43045-1911 |
| 20   | 43045-2012 | 43045-2013 | 43045-2014 | 43045-2111 |
| 22   | 43045-2212 | 43045-2213 | 43045-2214 | 43045-2311 |
| 24   | 43045-2412 | 43045-2413 | 43045-2414 | 43045-2511 |

|   |                        |                                       |                   |       |              |  |
|---|------------------------|---------------------------------------|-------------------|-------|--------------|--|
| FINISH A & D<br>EC NO: UCP2016-4586<br>DRAWN: JFOX 2015/12/10<br>CHKD: SSOUSEK 2015/12/10<br>APPR: FSM LTH 2016/08/23 | QUALITY SYMBOLS        | GENERAL TOLERANCES (UNLESS SPECIFIED) | DIMENSION STYLE   | SCALE | DESIGN UNITS | THIRD ANGLE PROJECTION   |
|   | ▽=0                    | mm INCH                               | IN/MM             | ---   | METRIC       |  |
|   | ▽=0                    | 4 PLACES ± --- ± ---                  | DRAWN BY DATE     |       |              | TITLE  |
|   | ▽=0                    | 3 PLACES ± --- ± .010                 | SAMIEC 2000/03/15 |       |              | MICRO FIT (3.0)<br>DUAL ROW VERTICAL THRU<br>HOLE HEADER ASS'Y |
|   | 2 PLACES ± 0.25 ± .014 | CHECKED BY DATE                       |                   |       |              | molex  |
|   | 1 PLACE ± 0.36 ± ---   | SSOUSEK 2016/06/01                    |                   |       |              |  |
|   | 0 PLACE ± --- ± ---    | APPROVED BY DATE                      |                   |       |              | DOCUMENT NO.   |
|   |                        | FSM LTH 2016/08/23                    |                   |       |              | SD-43045-005   |
|   |                        |                                       |                   |       |              | SHEET NO.  |
|   |                        |                                       |                   |       |              | 1 OF 1   |
|   |                        |                                       |                   |       |              |  |
|   |                        |                                       |                   |       |              |  |