



产品编号：[457503111](#)

Product Description：Mini-Fit Plus Crimp Terminal, 16 AWG, Reel, Copper (Cu) Alloy, Tin (Sn)

系列号：45750

状态：Active

Product Category：Crimp Terminals

Packaging Alternative：0457503112 (Bag)



文件和资源

图纸

[图纸 457503111_sd.pdf](#)

规格

[产品规格 PS-45750-001-001.pdf](#)

[产品规格 55560008-TS-000.pdf](#)

产物环境合规

合规

GADSL/IMDS	Compliant with Exemption 44; 34; 33
China RoHS	
EU ELV	Compliant per 2000/53/EC
Low-Halogen Status	Low-Halogen per IEC 61249-2-21
REACH SVHC	Not Contained per D(2023)3788-DC (14 Jun 2023)
EU RoHS	Compliant per EU 2015/863

[多部分产品合规性声明](#)

- Eu RoHS
- REACH SVHC
- Low-Halogen

[多部分行业合规性文件](#)

- IPC 1752A Class C
- IPC 1752A Class D
- Molex Product Compliance Declaration
- IEC-62474
- chemSHERPA (xml)

欧盟 RoHS 合格证书

产品详情

常规

状态	活动
类别	Crimp Terminals
系列	45750
说明	Mini-Fit Plus Crimp Terminal, 16 AWG, Reel, Copper (Cu) Alloy, Tin (Sn)
应用	Power, Wire-to-Board, Wire-to-Wire
个评论	Current = 13A max. per circuit when header is mated to a receptacle loaded with 45750 series terminals crimped to 16 AWG wire. See Molex product specification PS-45750-001 for additional current de-rating information. Series 45750 is Hot-Swappable
产品系列	Mini-Fit Family Power Connectors
产品名称	Mini-Fit Plus
UPC	822350286039

电气

每触点最大电流	13.0A
电压 - 最大	600V

物理

耐用性(插拔次数) - 最多次数	100
性别	女
材料 - 金属	Copper Alloy
材料 - 接合部位电镀	Tin
材料 - 终端电镀	Tin

净重	0.150/g
包装形式	Reel
最薄镀层 - 接合部位	2.540µm
最薄镀层 - 端接	2.540µm
终端界面类型	Crimp or Compression
导线绝缘直径	1.30-3.10mm
线径规格 (AWG)	16
线缆尺寸mm ²	不适用

进程

无铅	不适用
----	-----

可连接使用部件

描述	产品编号
Mini-Fit TPA Dual Row Receptacle Housings	<u>30067</u>
Mini-Fit BMI Dual Row Receptacle Housings	<u>42474</u>
Mini-Fit BMI Dual Row Receptacle Housings	<u>43760</u>
Mini-Fit BMI Dual Row Receptacle Housings	<u>44516</u>
Mini-Fit Jr. Receptacle Housings	<u>5557</u>

施工工具

全局

描述	产品编号
Extraction Tool for Mini-Fit Jr. Terminals	<u>0011030044</u>
Hand Crimp Tool for Mini-Fit Jr. Male and Female Crimp Terminals, 16 AWG	<u>2002182200</u>
FineAdjust Applicator for Insulation OD 2.20-2.45mm, 16 AWG	<u>0639039400</u>
FineAdjust Applicator for Insulation OD 2.60-3.15mm, 16 AWG	<u>0639041400</u>
FineAdjust Applicator for Insulation OD 1.80-2.20mm, 16 AWG	<u>0639041500</u>

This document was generated on Jan 30, 2024

ITEM NO.	FORM	WIRE GAGE	DIM "B"	DIM "C"	DIM "D"	DIM "E"	DIM "F"	DIM "G"	PLATING: SEE NOTE 2
457501111	CHAIN	18-20	.142±.012 (3.60±0.30)	.177±.016 (4.50±0.40)	.035±.016 (0.90±0.40)	.075±.012 (1.90±0.30)	.091±.016 (2.30±0.40)	.020 (0.50)	1 TIN OVER NICKEL
457501112	LOOSE								
457503111	CHAIN	16	.142±.012 (3.60±0.30)	.177±.016 (4.50±0.40)	.035±.016 (0.90±0.40)	.091±.012 (2.30±0.30)	.106±.016 (2.70±0.40)	.024 (0.60)	2 SELECT GOLD OVER NICKEL
457503112	LOOSE								
457501211	CHAIN	18-20	.142±.012 (3.60±0.30)	.177±.016 (4.50±0.40)	.035±.016 (0.90±0.40)	.075±.012 (1.90±0.30)	.091±.016 (2.30±0.40)	.020 (0.50)	2 SELECT GOLD OVER NICKEL
457501212	LOOSE								
457503211	CHAIN	16	.142±.012 (3.60±0.30)	.177±.016 (4.50±0.40)	.035±.016 (0.90±0.40)	.091±.012 (2.30±0.30)	.106±.016 (2.70±0.40)	.024 (0.60)	2 SELECT GOLD OVER NICKEL
457503212	LOOSE								
457502211	CHAIN	22-24	.091±.012 (2.30±0.30)	.091±.016 (2.30±0.40)	.024±.016 (0.60±0.40)	.071±.012 (1.80±0.30)	.065±.016 (1.65±0.40)	.016 (0.40)	2 SELECT GOLD OVER NICKEL

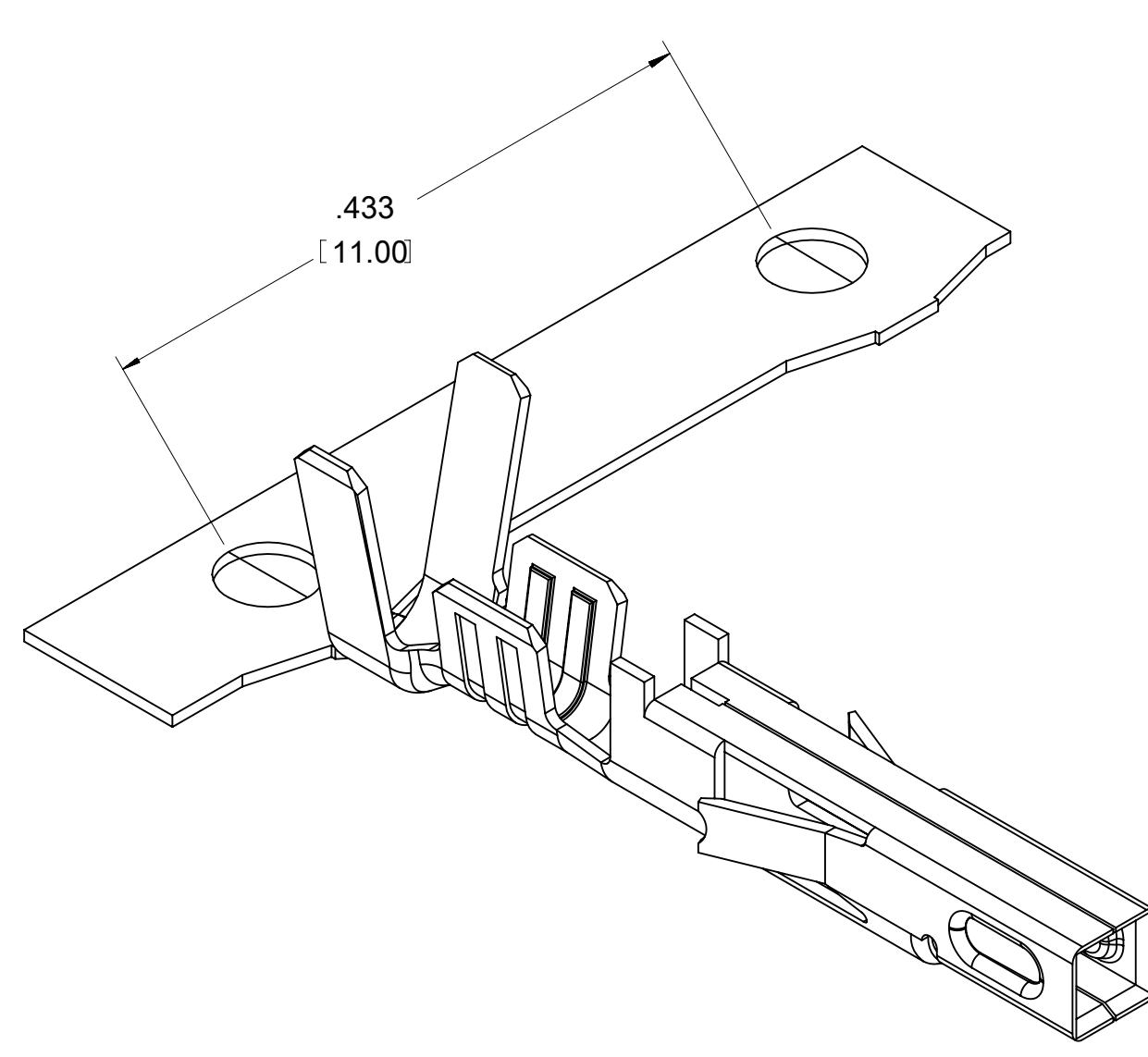

- NOTES:
- MATERIAL: COPPER ALLOY .0080/(0.203) THICK
 - FINISH:
 - .000100/(0.00254) MIN. BRIGHT TIN OVER .000050/(0.00127) MIN NICKEL OVERALL.
 - .000030/(0.00076) MIN. SELECT GOLD IN CONTACT AREA AND .000100/(0.00254) MIN. SELECT MATTE TIN IN CRIMP AREA OVER .000050/(0.00127) MIN. NICKEL OVERALL.

GOLD PLATING RECOMMENDED FOR APPLICATIONS WHERE FRETTING CORROSION IS A CONCERN.
 - PRODUCT SPECIFICATION: PS-45750-001
 - PACKAGING SPECIFICATION : 55560001-PK FOR CHAIN TERMINALS
PK-5556-003 FOR LOOSE TERMINALS
 - TERMINAL FOR USE WITH 5557, 42474, 44516, 43760, AND 30067 SERIES HOUSINGS.
 - WHEN TERMINALS ARE INSTALLED IN THE HOUSING, THE WIRES ARE TO BE DRESSED IN SUCH A MANNER TO ALLOW THE TERMINALS TO FLOAT FREELY IN THE POCKET.
 - THIS TERMINAL IS DESIGNED FOR SINGLE WIRE CRIMPING.
 - TEXT ON PART IS FOR REFERENCE ONLY. TEXT AND TEXT LOCATION MAY VARY DEPENDING ON PART NUMBER AND/OR TOOL.

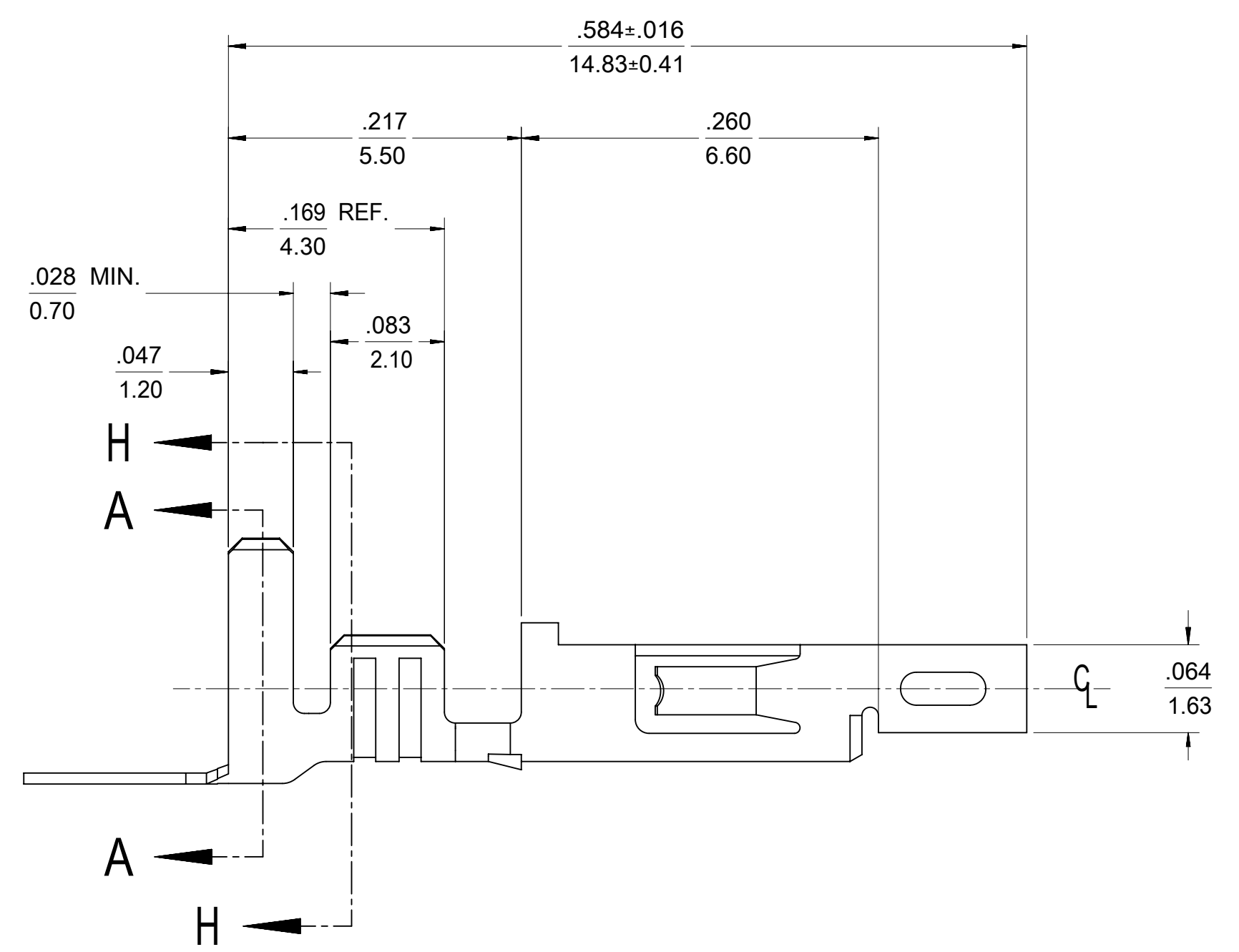
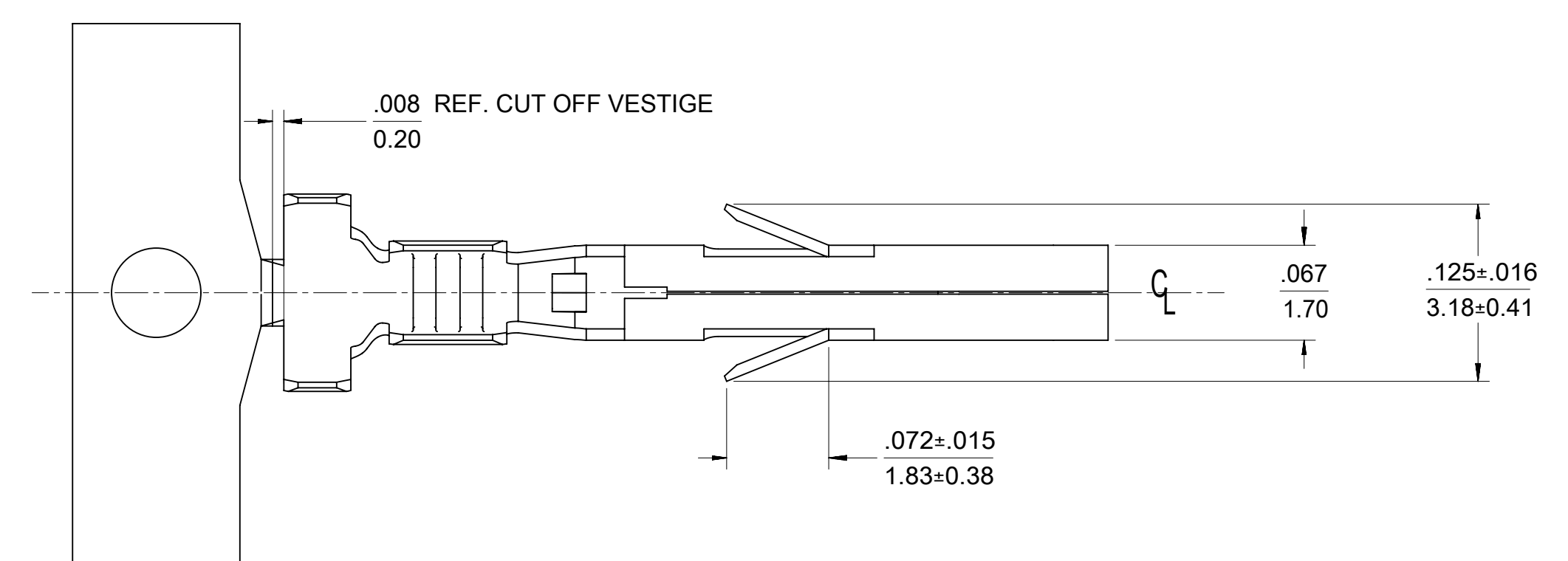

LEGEND

457501***

- BASE NUMBER
- FORM
1 = CHAIN
2 = LOOSE
- WIRE GAGE
1 = 18-20
2 = 22-24
3 = 16
- PLATING (SEE NOTE 2)
1 = TIN OVER NICKEL
2 = SELECT GOLD

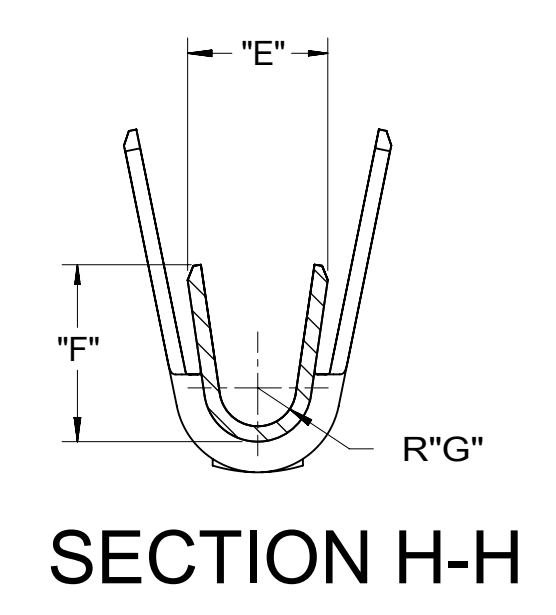
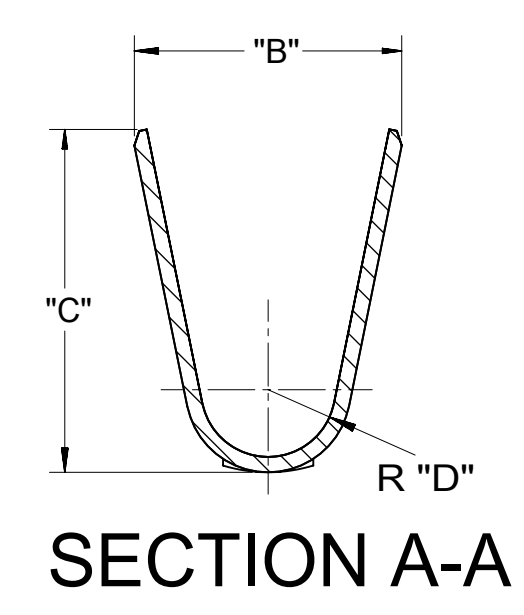
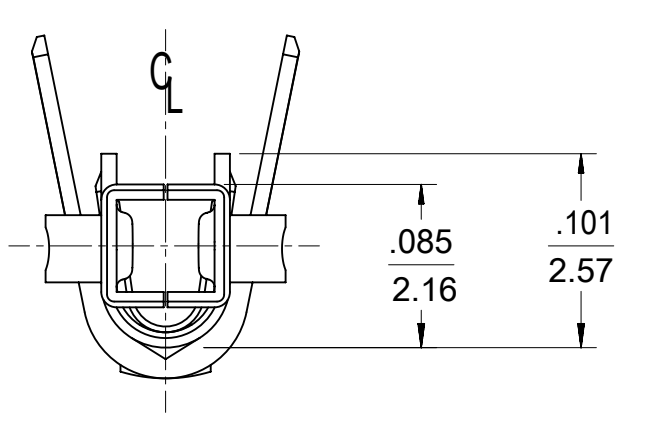

THIS DRAWING CONTAINS INFORMATION THAT IS PROPRIETARY TO MOLEX ELECTRONIC TECHNOLOGIES, LLC AND SHOULD NOT BE USED WITHOUT WRITTEN PERMISSION									
DIMENSION UNITS HYBRID		SCALE NTS		CURRENT REV DESC:				molex	
GENERAL TOLERANCES (UNLESS SPECIFIED)				EC NO: 697654 DRWN: HPAN18 CHK'D: XQZHANG APPR: XQZHANG					
		MM	INCH	2022/03/01 2022/03/08 2022/03/08				FEMALE CRIMP TERMINAL, PLUS HCS MINI-FIT JR. SERIES	
4 PLACES	±	±		INITIAL REVISION:				PRODUCT CUSTOMER DRAWING	
3 PLACES	±	± 0.01		DRWN: SML APPR: AP				DOCUMENT NUMBER	
2 PLACES	±	0.25	± 0.014	2004/01/30 2004/02/05				DOC TYPE DOC PART REVISION	
1 PLACE	±	0.36	±	D-SIZE 45750				SD-45750-001 PSD 001 G6	
0 PLACES	±	±		MATERIAL NUMBER CUSTOMER SHEET NUMBER				SEE CHART GENERAL MARKET 1 OF 1	
ANGULAR TOL ± 0.5 °				THIRD ANGLE PROJECTION					
DRAFT WHERE APPLICABLE MUST REMAIN WITHIN DIMENSIONS				DRAWING		SERIES			