



产品编号 : 5051101092

**Product Description** : Easy-On FFC/FPC Connector, 0.50mm Pitch, FD19 Series, Right-Angle, Bottom Contact, 1.90mm Height, 10 Circuits, Gold over Nickel Plating

系列号 : 505110

状态 : Active

Product Category : FFC / FPC Connectors

---

## 文件和资源

### 图纸

图纸 5051101092\_sd.pdf

### 3D 模型和设计文件

3D模型 5051101092\_stp.zip

### 规格

包装规格 5051109200-200.pdf

包装规格 5051109200-201.pdf

产品规格 5051100000-PS-000.pdf

---

## 产物环境合规

### 合规

GADSL/IMDS	Compliant with Exemption 44; 33
China RoHS	
EU ELV	Not Relevant
Low-Halogen Status	Low-Halogen per IEC 61249-2-21
REACH SVHC	Not Contained per D(2023)8585-DC (23 Jan 2024)
EU RoHS	Compliant per EU 2015/863

### 多部分产品合规性声明

- Eu RoHS
- REACH SVHC
- Low-Halogen
  
- IPC 1752A Class C
- IPC 1752A Class D
- Molex Product Compliance Declaration

- IEC-62474

- chemSHERPA (xml)

欧盟 RoHS 合格证书

## 产品详情

### 常规

状态	活动
类别	FFC / FPC Connectors
系列	505110
说明	Easy-On FFC/FPC Connector, 0.50mm Pitch, FD19 Series, Right-Angle, Bottom Contact, 1.90mm Height, 10 Circuits, Gold over Nickel Plating
产品系列	FD19
个评论	Black Actuator
产品系列	Easy-On FFC FPC Connectors
产品名称	Easy-On
UPC	889056255844

### 电气

每触点最大电流	0.5A
电压 - 最大	50V

### 物理

驱动器类型	Front Flip
回路数 (已载入)	10
颜色-树脂	米黄色
接触部位	底部
耐用性(插拔次数) - 最多次数	20
插配长度	1.90mm
材料 - 金属	Phosphor Bronze
材料 - 接合部位电镀	金牌
材料 - 终端电镀	金牌
材料 - 树脂	Liquid Crystal Polymer
净重	113.440/mg

方向	Right Angle
包装形式	Embossed Tape on Reel
PCB 定位器	否
PCB安装	Surface Mount
PCB 保持力	是
间距 - 插配接口	0.50mm
间距 - 终端界面	0.50mm
最薄镀层 - 接合部位	0.051µm
最薄镀层 - 端接	0.051µm
PCB 极性	是
可堆叠的	否
运行温度范围	-40° to +105° C
导线/电缆型号	FFC/FPC

---

## 可配插/可连接使用的产品

### 可配插部件

描述	产品编号
0.50mm Pitch Premo-Flex FFC Jumpers with Ears	<u>15018</u>
0.50mm Pitch Premo-Flex FFC Jumpers	<u>15020</u>
0.50mm Pitch Premo-Flex FFC Jumpers	<u>15120</u>

引き出し方向  
PULL DIRECTION

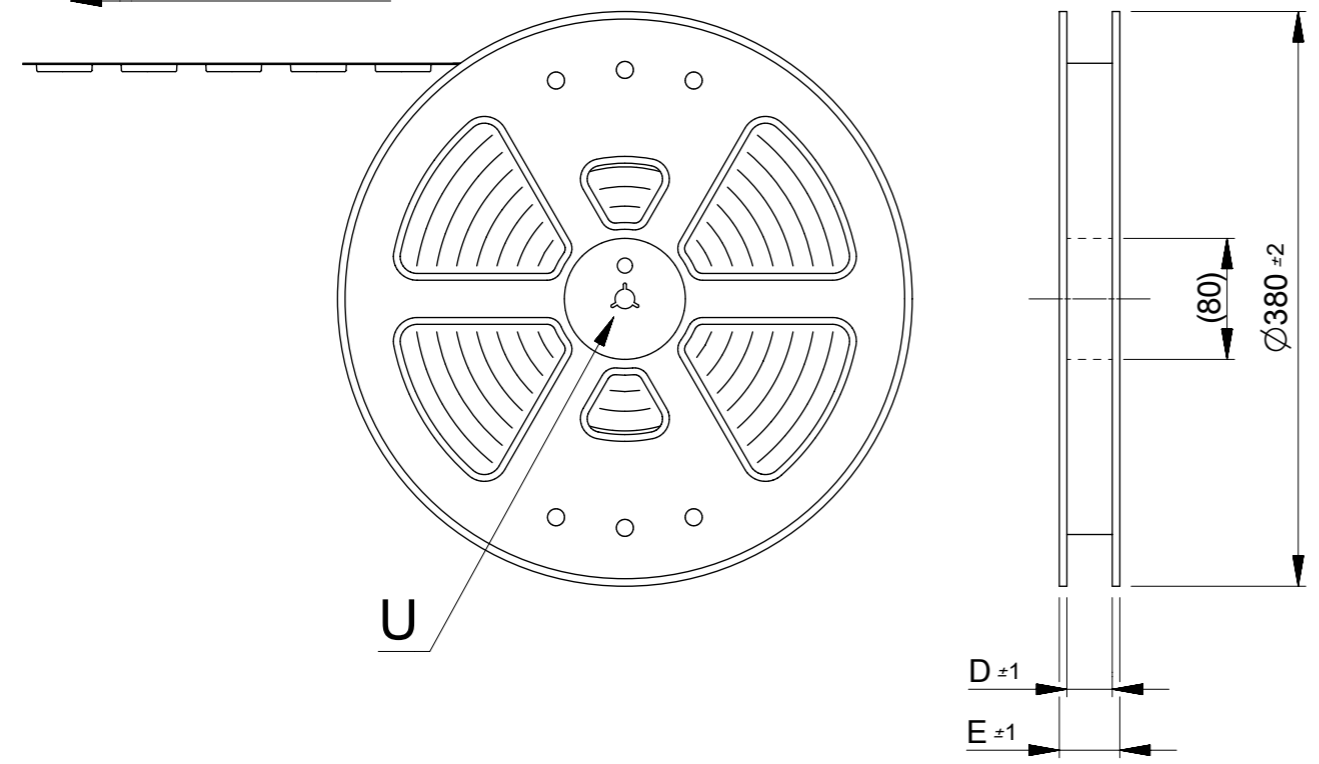

U

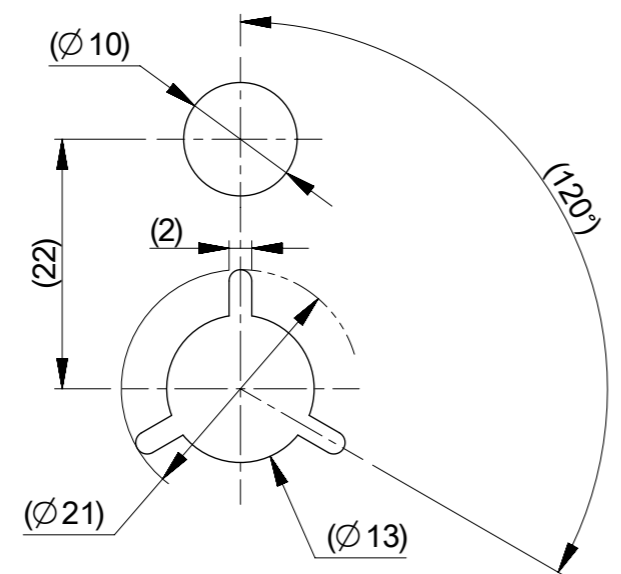

DETAIL U

NOTES

- 梱包数量 : 3000個 / リール  
NUMBER OF CONNECTORS : 3000 PCS/REEL.
- リードテープ長さ  
LEAD TAPE LENGTH

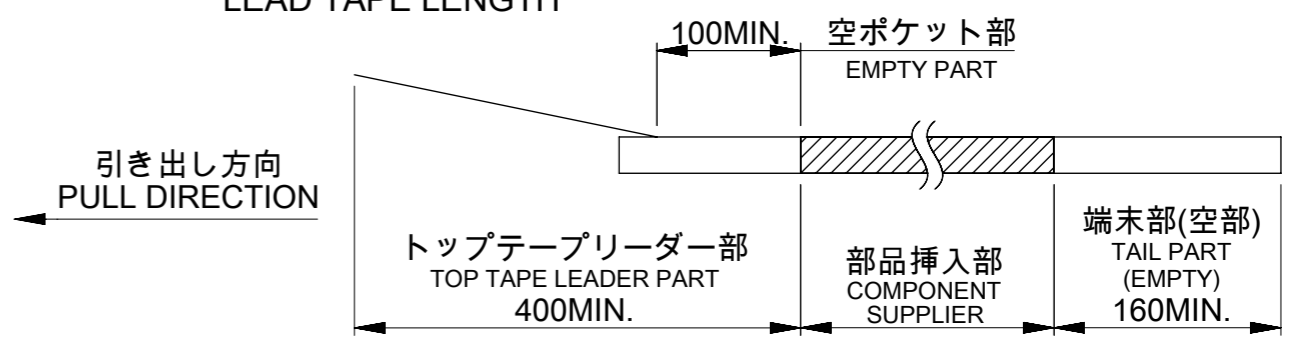

- カバーテープの剥離強度については、IEC60286-3に準拠。  
COVER TAPE PEEL FORCE IS DEFINED BY IEC 60286-3.
- 製品詳細寸法については、図面 5051101000-SD を参照下さい。  
DIMENSIONS OF PRODUCT, REFER TO 5051101000-SD.
- 材料 MATERIAL  
 キャリアテープ : ポリスチレン  
 トップテープ : ポリエチレンテレフタレート、ポリエチレン  
 リール : ポリスチレン <リサイクル材を含む>  
 CARRIER TAPE : POLYSTYRENE  
 TOP TAPE : POLYETHYLENE TEREPHTHALATE, POLYETHYLENE  
 REEL : POLYSTYRENE < RECYCLE MATERIAL CONTAINED >

THIS DRAWING CONTAINS INFORMATION THAT IS PROPRIETARY TO MOLEX ELECTRONIC TECHNOLOGIES, LLC AND SHOULD NOT BE USED WITHOUT WRITTEN PERMISSION		CURRENT REV DESC:		<b>molex</b>	
DIMENSION UNITS	SCALE				
mm	2:1			0.5 FPC ZIF 2 CONT EMBT PKG	
GENERAL TOLERANCES (UNLESS SPECIFIED)		EC NO: 605617		PRODUCT CUSTOMER DRAWING	
ANGULAR TOL	± 3.0 °	DRWN: JASANUMA	2018/09/28	DOCUMENT NUMBER	
4 PLACES	± 0.2	CHK'D: TRSUZUKI	2018/10/10	5051100000-SD	
3 PLACES	± 0.2	APPR: RTAKEUCHI	2018/10/10	DOC TYPE	DOC PART
2 PLACES	± 0.2	INITIAL REVISION:		PSD	000
1 PLACE	± 0.25	DRWN: JASANUMA	2018/09/28	REVISION	
0 PLACES	± 0.3	APPR: RTAKEUCHI	2018/10/10	A	
DRAFT WHERE APPLICABLE MUST REMAIN WITHIN DIMENSIONS		THIRD ANGLE PROJECTION	DRAWING	SERIES	MATERIAL NUMBER
			A3-SIZE	505110	SEE CHART
				CUSTOMER	SHEET NUMBER
					1 OF 3

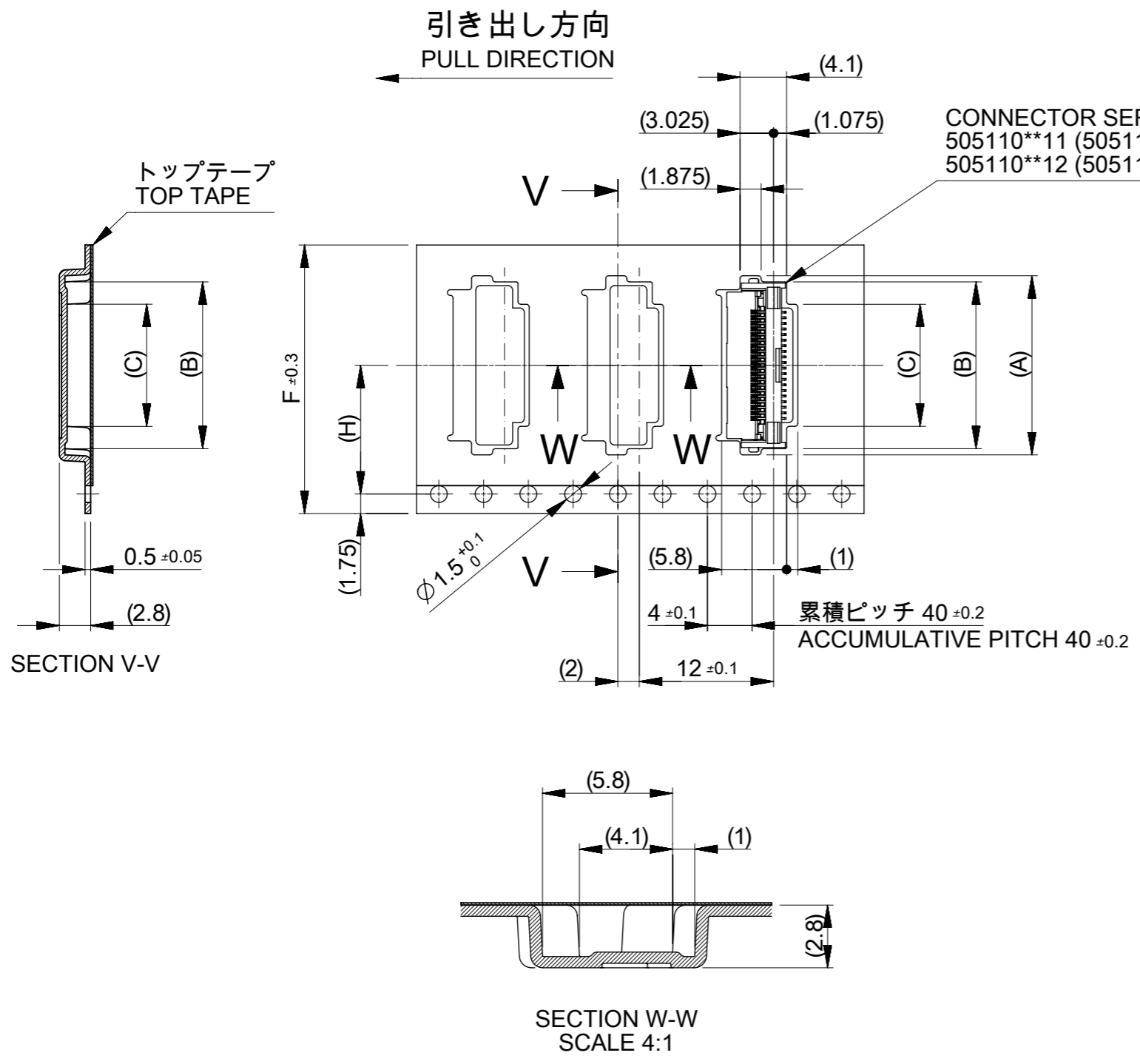

11.5	----	24	29.4	25.4	10.9	14.9	16	5051102091	20
					10.4	14.4	15.5	5051101992	19
					9.9	13.9	15	5051101892	18
					9.4	13.4	14.5	5051101792	17
					8.9	12.9	14	5051101692	16
					8.4	12.4	13.5	5051101592	15
					7.9	11.9	13	5051101492	14
					7.4	11.4	12.5	5051101392	13
					6.9	10.9	12	5051101292	12
					6.4	10.4	11.5	5051101192	11
					5.9	9.9	11	5051101092	10
					5.4	9.4	10.5	5051100992	9
					4.9	8.9	10	5051100892	8
4.4	8.4	9.5	5051100792	7					
3.9	7.9	9	5051100692	6					
3.4	7.4	8.5	5051100592	5					
7.5	----	16	21.4	17.4	2.9	6.9	8	5051100492	4
H	G	F	E	D	C	B	A	EMBOSSED PACKAGE	Ckt
オーダー番号 ORDER No.									

THIS DRAWING CONTAINS INFORMATION THAT IS PROPRIETARY TO MOLEX ELECTRONIC TECHNOLOGIES, LLC AND SHOULD NOT BE USED WITHOUT WRITTEN PERMISSION

DIMENSION UNITS	SCALE	CURRENT REV DESC:		<b>molex</b>			
mm	2:1						
GENERAL TOLERANCES (UNLESS SPECIFIED)		EC NO: 605617		0.5 FPC ZIF 2 CONT EMBT PKG			
ANGULAR TOL ± 3.0°		DRWN: JASANUMA 2018/09/28		PRODUCT CUSTOMER DRAWING			
4 PLACES ± 0.2		CHK'D: TRSUZUKI 2018/10/10		DOCUMENT NUMBER			
3 PLACES ± 0.2		APPR: RTAKEUCHI 2018/10/10		5051100000-SD			
2 PLACES ± 0.2		INITIAL REVISION:		DOC TYPE			
1 PLACE ± 0.25		DRWN: JASANUMA 2018/09/28		PSD			
0 PLACES ± 0.3		APPR: RTAKEUCHI 2018/10/10		DOC PART			
DRAFT WHERE APPLICABLE MUST REMAIN WITHIN DIMENSIONS		THIRD ANGLE PROJECTION		REVISION			
		DRAWING		A			
		SERIES		SHEET NUMBER			
		A3-SIZE		2 OF 3			
		505110		MATERIAL NUMBER			
		SEE CHART		CUSTOMER			

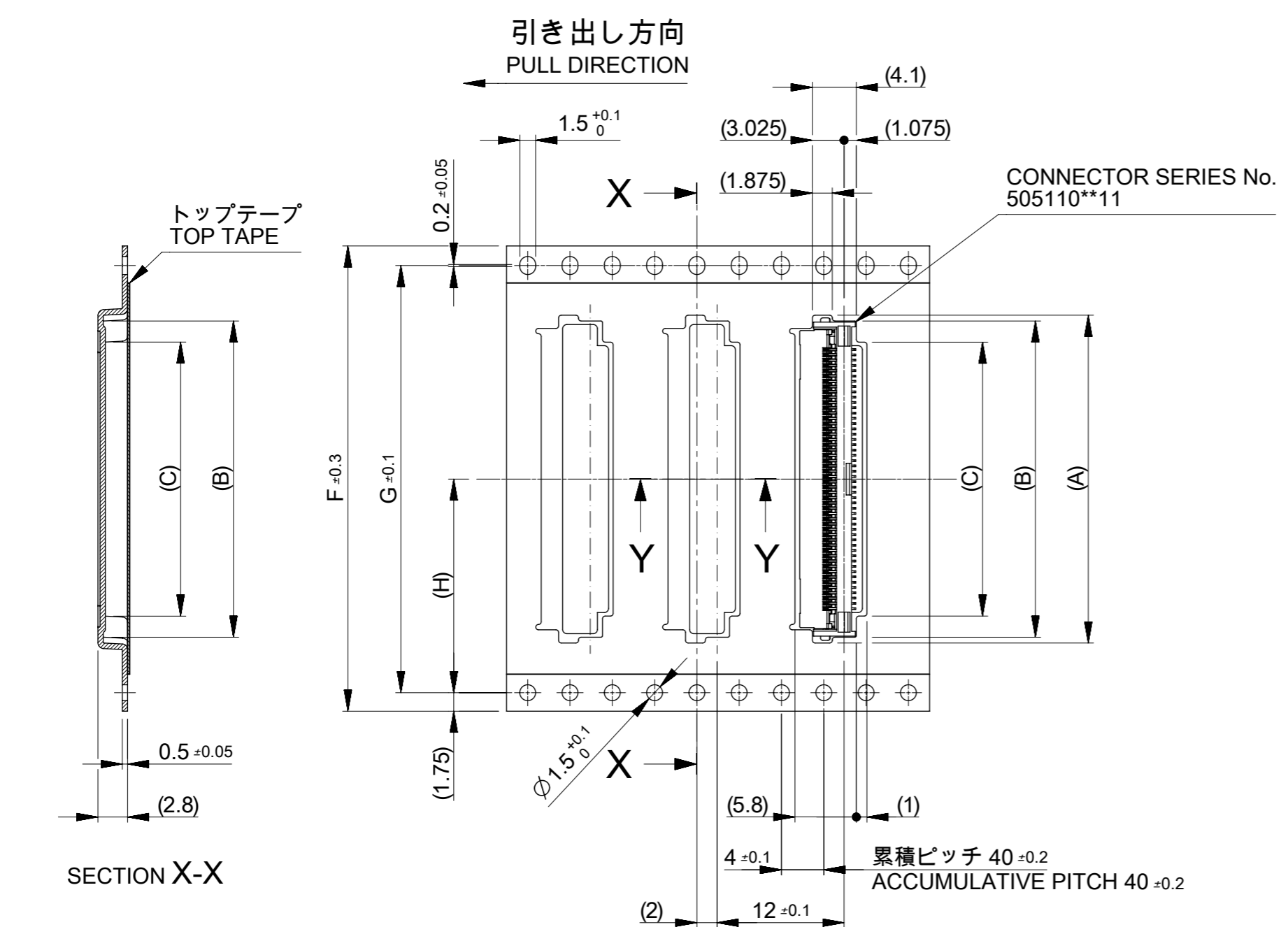

					40.9	44.9	46	5051108091	80
					35.9	39.9	41	5051107091	70
					34.9	38.9	40	5051106891	68
					32.9	36.9	38	5051106491	64
					31.4	35.4	36.5	5051106191	61
					30.9	34.9	36	5051106091	60
					30.4	34.4	35.5	5051105991	59
					29.9	33.9	35	5051105891	58
					29.4	33.4	34.5	5051105791	57
					28.9	32.9	34	5051105691	56
H	G	F	E	D	C	B	A	EMBOSSED PACKAGE	Ckt
								オーダー番号 ORDER No.	

26.2	52.4	56	61.4	57.4	28.4	32.4	33.5	5051105591	55
					27.9	31.9	33	5051105491	54
					27.4	31.4	32.5	5051105391	53
					26.9	30.9	32	5051105291	52
					26.4	30.4	31.5	5051105191	51
					25.9	29.9	31	5051105091	50
					25.4	29.4	30.5	5051104991	49
					24.9	28.9	30	5051104891	48
					24.4	28.4	29.5	5051104791	47
					23.9	27.9	29	5051104691	46
					23.4	27.4	28.5	5051104591	45
					22.9	26.9	28	5051104491	44
					22.4	26.4	27.5	5051104391	43
					21.9	25.9	27	5051104291	42
					21.4	25.4	26.5	5051104191	41
					20.9	24.9	26	5051104091	40
					20.4	24.4	25.5	5051103991	39
					19.9	23.9	25	5051103891	38
					19.4	23.4	24.5	5051103791	37
					18.9	22.9	24	5051103691	36
					18.4	22.4	23.5	5051103591	35
					17.9	21.9	23	5051103491	34
					17.4	21.4	22.5	5051103391	33
					16.9	20.9	22	5051103291	32
					16.4	20.4	21.5	5051103191	31
					15.9	19.9	21	5051103091	30
					15.4	19.4	20.5	5051102991	29
					14.9	18.9	20	5051102891	28
					14.4	18.4	19.5	5051102791	27
					13.9	17.9	19	5051102691	26
					13.4	17.4	18.5	5051102591	25
					12.9	16.9	18	5051102491	24
					12.4	16.4	17.5	5051102391	23
					11.9	15.9	17	5051102291	22
					11.4	15.4	16.5	5051102191	21
H	G	F	E	D	C	B	A	EMBOSSED PACKAGE	Ckt
								オーダー番号 ORDER No.	

THIS DRAWING CONTAINS INFORMATION THAT IS PROPRIETARY TO MOLEX ELECTRONIC TECHNOLOGIES, LLC AND SHOULD NOT BE USED WITHOUT WRITTEN PERMISSION

DIMENSION UNITS	SCALE	CURRENT REV DESC:	
mm	2:1		
GENERAL TOLERANCES (UNLESS SPECIFIED)			
ANGULAR TOL	± 3.0°	EC NO: 605617	
4 PLACES	± 0.2	DRWN: JASANUMA	2018/09/28
3 PLACES	± 0.2	CHK'D: TRSUZUKI	2018/10/10
2 PLACES	± 0.2	APPR: RTAKEUCHI	2018/10/10
1 PLACE	± 0.25	INITIAL REVISION:	
0 PLACES	± 0.3	DRWN: JASANUMA	2018/09/28
		APPR: RTAKEUCHI	2018/10/10
DRAFT WHERE APPLICABLE MUST REMAIN WITHIN DIMENSIONS		THIRD ANGLE PROJECTION	DRAWING
			A3-SIZE
		SERIES	MATERIAL NUMBER
		5051110	SEE CHART
		CUSTOMER	SHEET NUMBER
			3 OF 3

**molex**

0.5 FPC ZIF 2 CONT EMBT PKG

PRODUCT CUSTOMER DRAWING

DOCUMENT NUMBER	DOC TYPE	DOC PART	REVISION
5051100000-SD	PSD	000	A

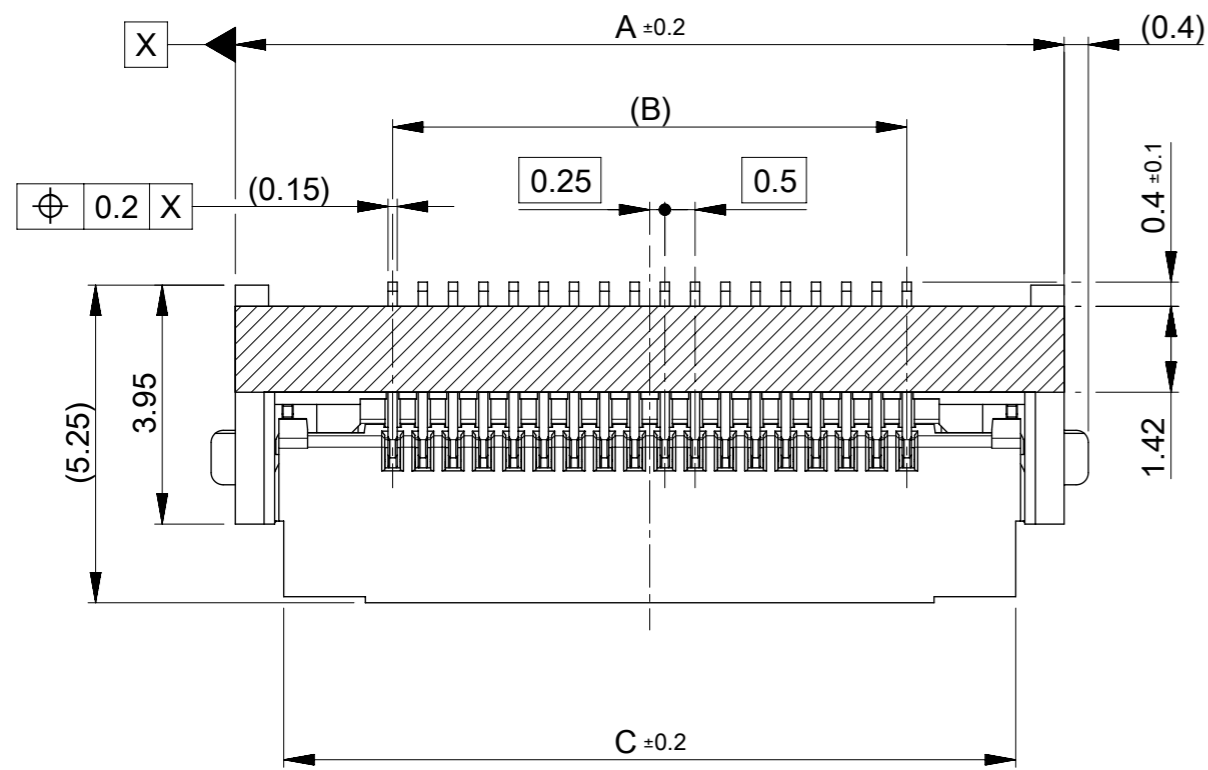

: PICK UP AREA

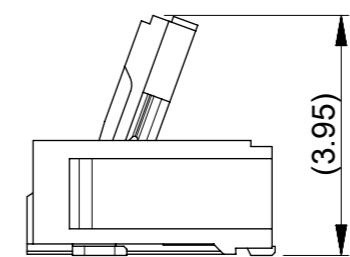
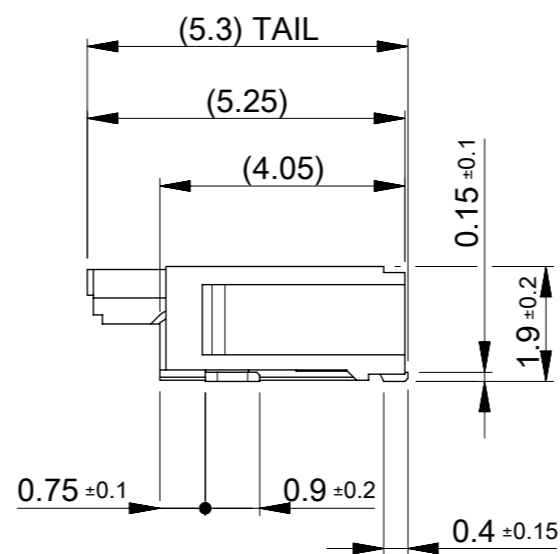
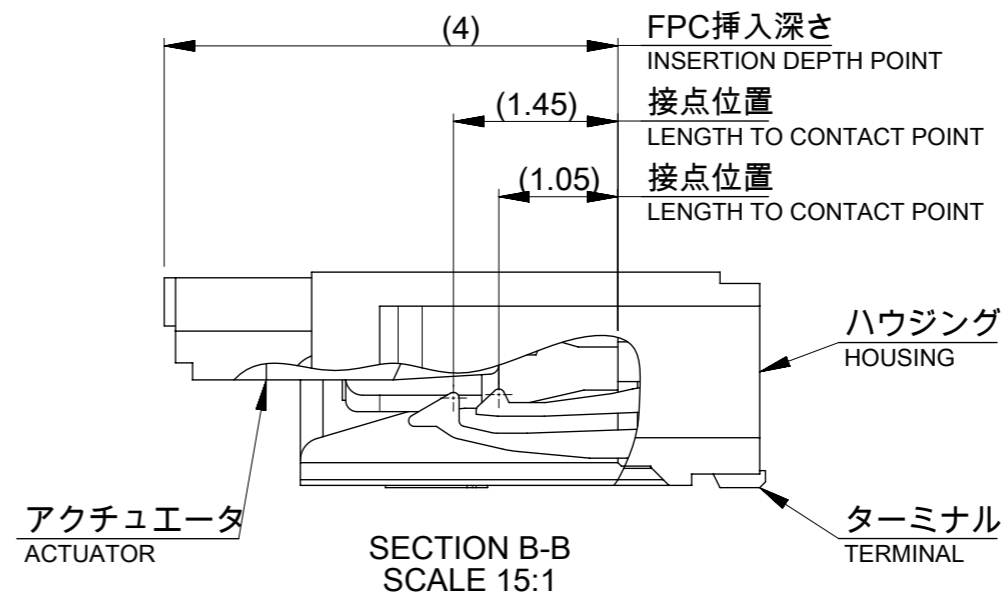
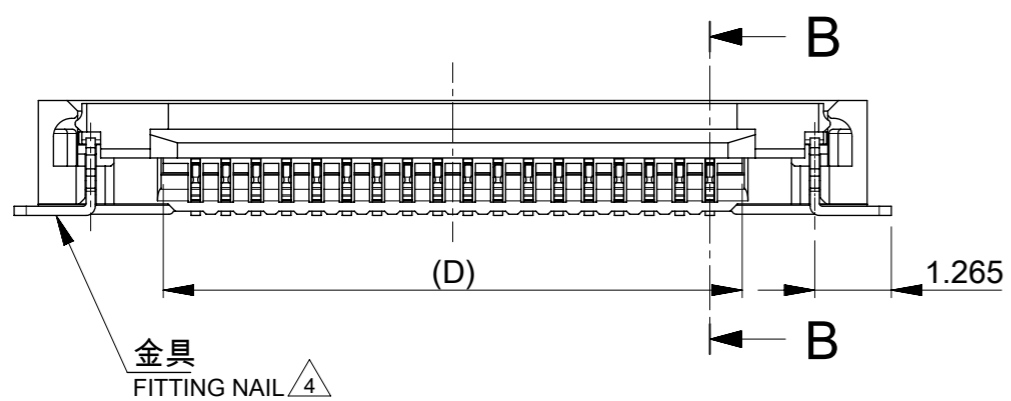

10.07	12.6	9	14.2	5051101992	19
9.57	12.1	8.5	13.7	5051101892	18
9.07	11.6	8	13.2	5051101792	17
8.57	11.1	7.5	12.7	5051101692	16
8.07	10.6	7	12.2	5051101592	15
7.57	10.1	6.5	11.7	5051101492	14
7.07	9.6	6	11.2	5051101392	13
6.57	9.1	5.5	10.7	5051101292	12
6.07	8.6	5	10.2	5051101192	11
5.57	8.1	4.5	9.7	5051101092	10
5.07	7.6	4	9.2	5051100992	9
4.57	7.1	3.5	8.7	5051100892	8
4.07	6.6	3	8.2	5051100792	7
3.57	6.1	2.5	7.7	5051100692	6
3.07	5.6	2	7.2	5051100592	5
2.57	5.1	1.5	6.7	5051100492	4
D	C	B	A	EMBOSSED PACKAGE	Ckt
				オーダー番号 ORDER No.	

THIS DRAWING CONTAINS INFORMATION THAT IS PROPRIETARY TO MOLEX ELECTRONIC TECHNOLOGIES, LLC AND SHOULD NOT BE USED WITHOUT WRITTEN PERMISSION

DIMENSION UNITS <b>mm</b>	SCALE <b>8:1</b>	CURRENT REV DESC:		<b>molex</b>		
GENERAL TOLERANCES (UNLESS SPECIFIED)		EC NO: 720907				
ANGULAR TOL ± 3.0 °	4 PLACES ± 0.2	DRWN: RAJMOK	2022/09/21	PRODUCT CUSTOMER DRAWING		
3 PLACES ± 0.2	2 PLACES ± 0.2	CHK'D: YNUKANOBU	2022/09/22	DOCUMENT NUMBER		
1 PLACE ± 0.25	0 PLACES ± 0.3	APPR: YNAITO	2022/09/22	DOC TYPE DOC PART REVISION		
DRAFT WHERE APPLICABLE MUST REMAIN WITHIN DIMENSIONS		INITIAL REVISION:	2018/10/01	5051101000-SD		
THIRD ANGLE PROJECTION		DRWN: JASANUMA	2018/10/10	PSD 000 B		
DRAWING		APPR: RTAKEUCHI		MATERIAL NUMBER		
A3-SIZE		SERIES	505110	CUSTOMER		
SHEET NUMBER				1 OF 4		

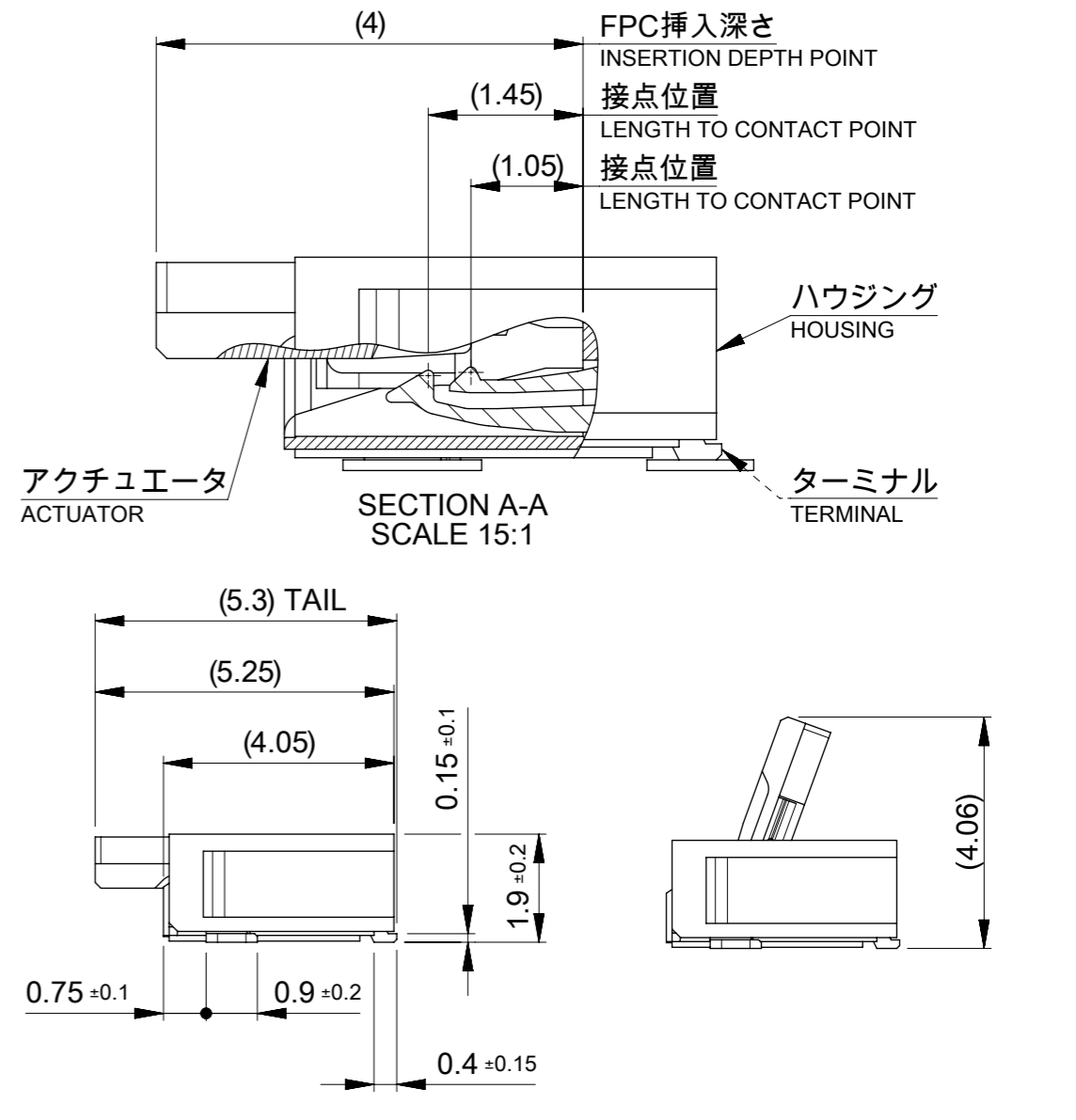
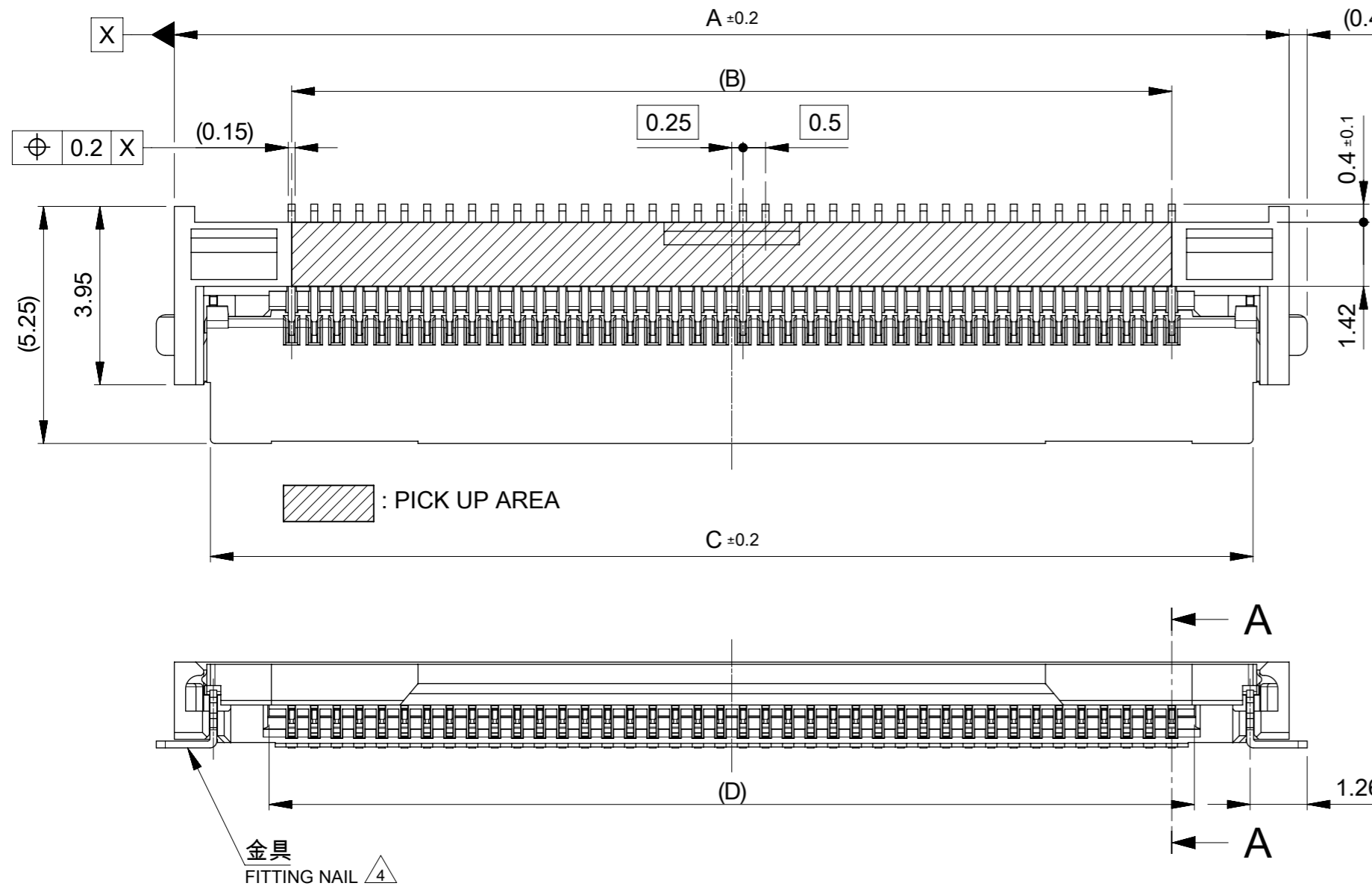

40.5	43.1	39.5	44.7	5051108091	80	25	27.6	24	29.2	5051104991	49	20	22.6	19	24.2	5051103991	39	15	17.6	14	19.2	5051102991	29
35.5	38.1	34.5	39.7	5051107091	70	24.5	27.1	23.5	28.7	5051104891	48	19.5	22.1	18.5	23.7	5051103891	38	14.5	17.1	13.5	18.7	5051102891	28
34.5	37.1	33.5	38.7	5051106891	68	24	26.6	23	28.2	5051104791	47	19	21.6	18	23.2	5051103791	37	14	16.6	13	18.2	5051102791	27
32.5	35.1	31.5	36.7	5051106491	64	23.5	26.1	22.5	27.7	5051104691	46	18.5	21.1	17.5	22.7	5051103691	36	13.5	16.1	12.5	17.7	5051102691	26
31	33.6	30	35.2	5051106191	61	23	25.6	22	27.2	5051104591	45	18	20.6	17	22.2	5051103591	35	13	15.6	12	17.2	5051102591	25
30.5	33.1	29.5	34.7	5051106091	60	22.5	25.1	21.5	26.7	5051104491	44	17.5	20.1	16.5	21.7	5051103491	34	12.5	15.1	11.5	16.7	5051102491	24
30	32.6	29	34.2	5051105991	59	22	24.6	21	26.2	5051104391	43	17	19.6	16	21.2	5051103391	33	12	14.6	11	16.2	5051102391	23
29.5	32.1	28.5	33.7	5051105891	58	21.5	24.1	20.5	25.7	5051104291	42	16.5	19.1	15.5	20.7	5051103291	32	11.5	14.1	10.5	15.7	5051102291	22
29	31.6	28	33.2	5051105791	57	21	23.6	20	25.2	5051104191	41	16	18.6	15	20.2	5051103191	31	11	13.6	10	15.2	5051102191	21
28.5	31.1	27.5	32.7	5051105691	56	20.5	23.1	19.5	24.7	5051104091	40	15.5	18.1	14.5	19.7	5051103091	30	10.5	13.1	9.5	14.7	5051102091	20
28	30.6	27	32.2	5051105591	55	D	C	B	A	EMBOSSED PACKAGE	Ckt	D	C	B	A	EMBOSSED PACKAGE	Ckt	D	C	B	A	EMBOSSED PACKAGE	Ckt
27.5	30.1	26.5	31.7	5051105491	54					オーダー番号 ORDER No.						オーダー番号 ORDER No.						オーダー番号 ORDER No.	
27	29.6	26	31.2	5051105391	53					EMBOSSED PACKAGE	Ckt					EMBOSSED PACKAGE	Ckt					EMBOSSED PACKAGE	Ckt
26.5	29.1	25.5	30.7	5051105291	52					オーダー番号 ORDER No.						オーダー番号 ORDER No.						オーダー番号 ORDER No.	
26	28.6	25	30.2	5051105191	51					EMBOSSED PACKAGE	Ckt					EMBOSSED PACKAGE	Ckt					EMBOSSED PACKAGE	Ckt
25.5	28.1	24.5	29.7	5051105091	50					オーダー番号 ORDER No.						オーダー番号 ORDER No.						オーダー番号 ORDER No.	



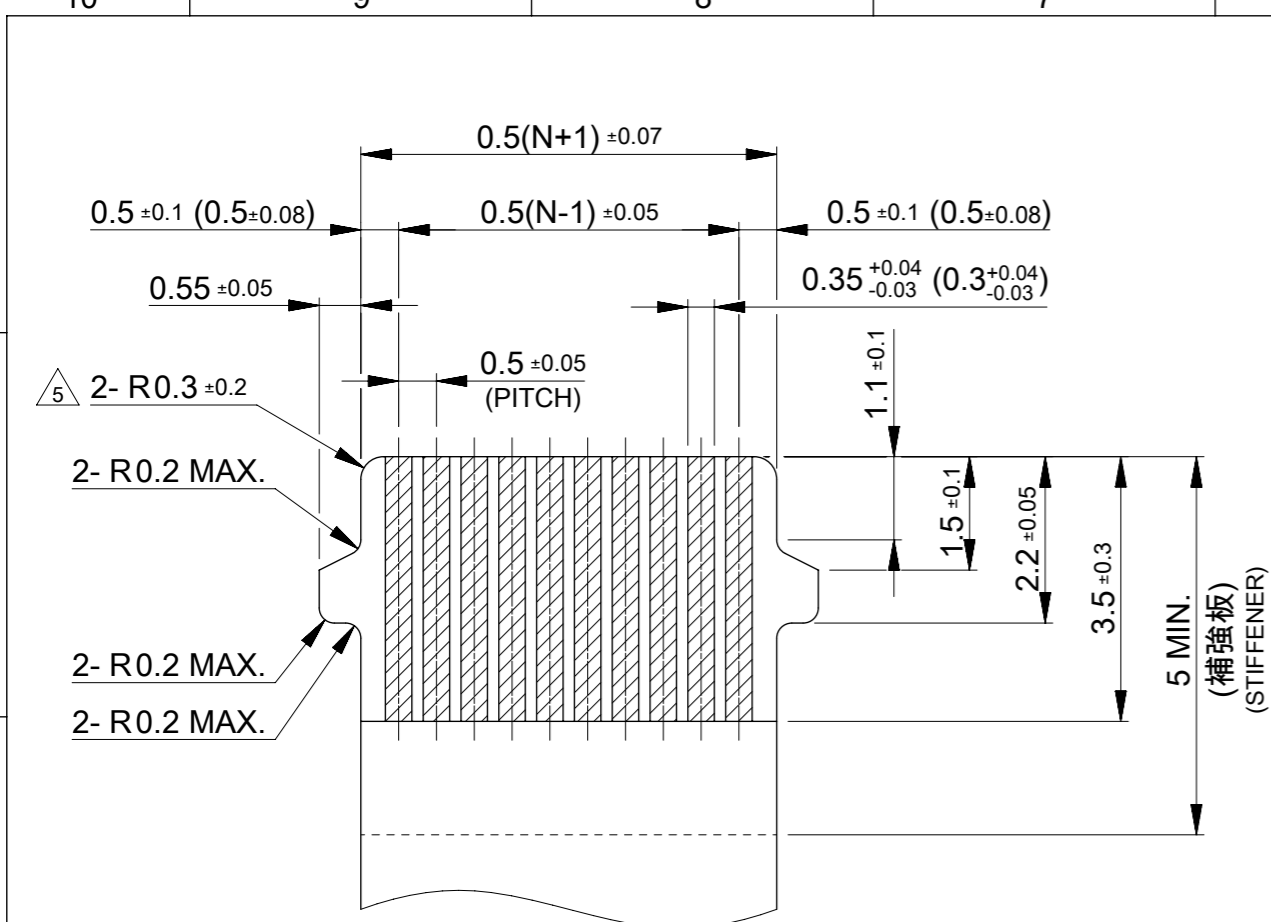

適合FPC/FFC推奨寸法  
 APPLICABLE FPC/FFC RECOMMENDED DIMENSION

( ) : FFCに適用  
 ( ) : APPLY TO FFC

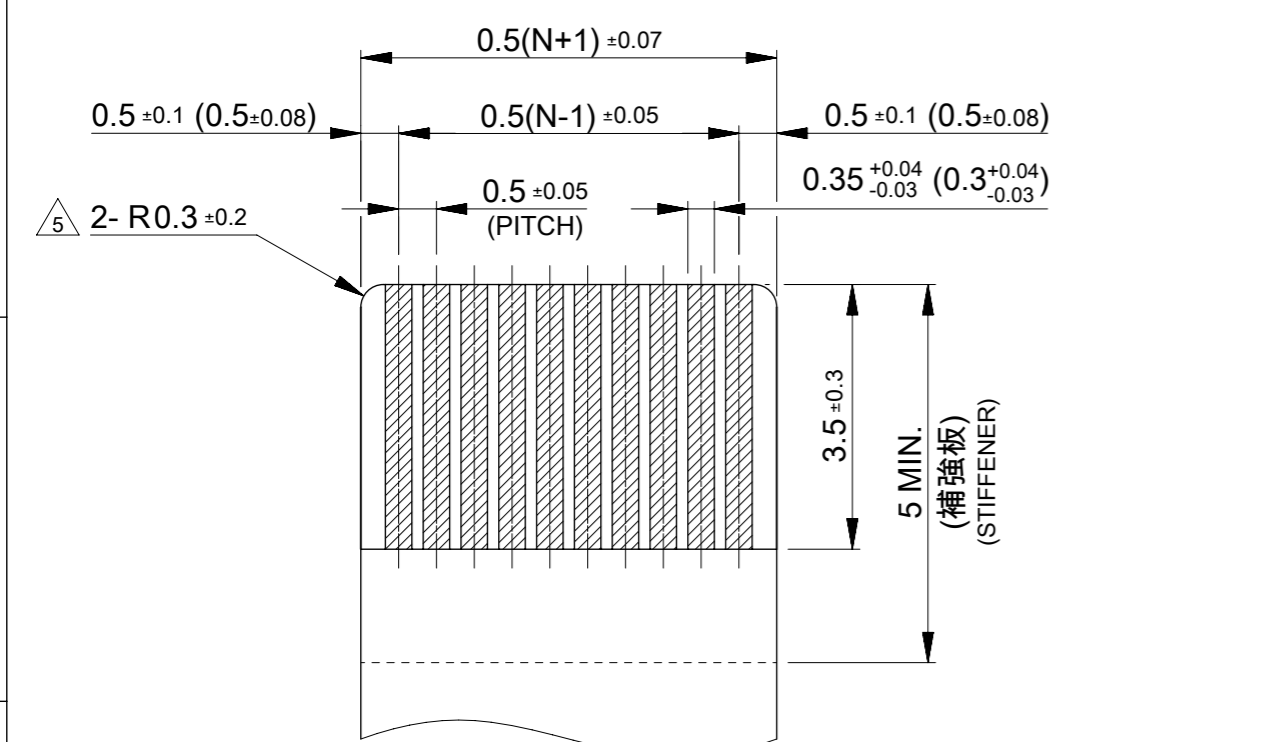

適合FPC/FFC推奨寸法  
 APPLICABLE FPC/FFC RECOMMENDED DIMENSION

( ) : FFCに適用  
 ( ) : APPLY TO FFC

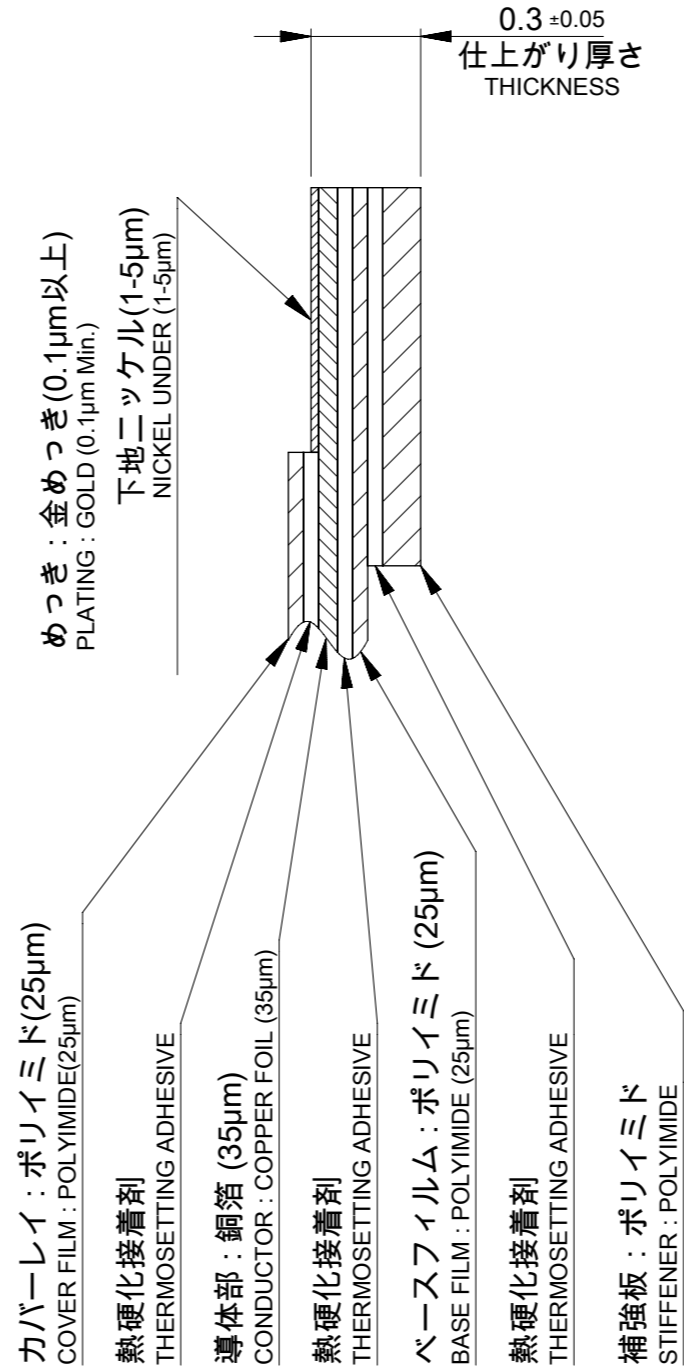

FPC構成推奨仕様  
 STRUCTURE OF FPC

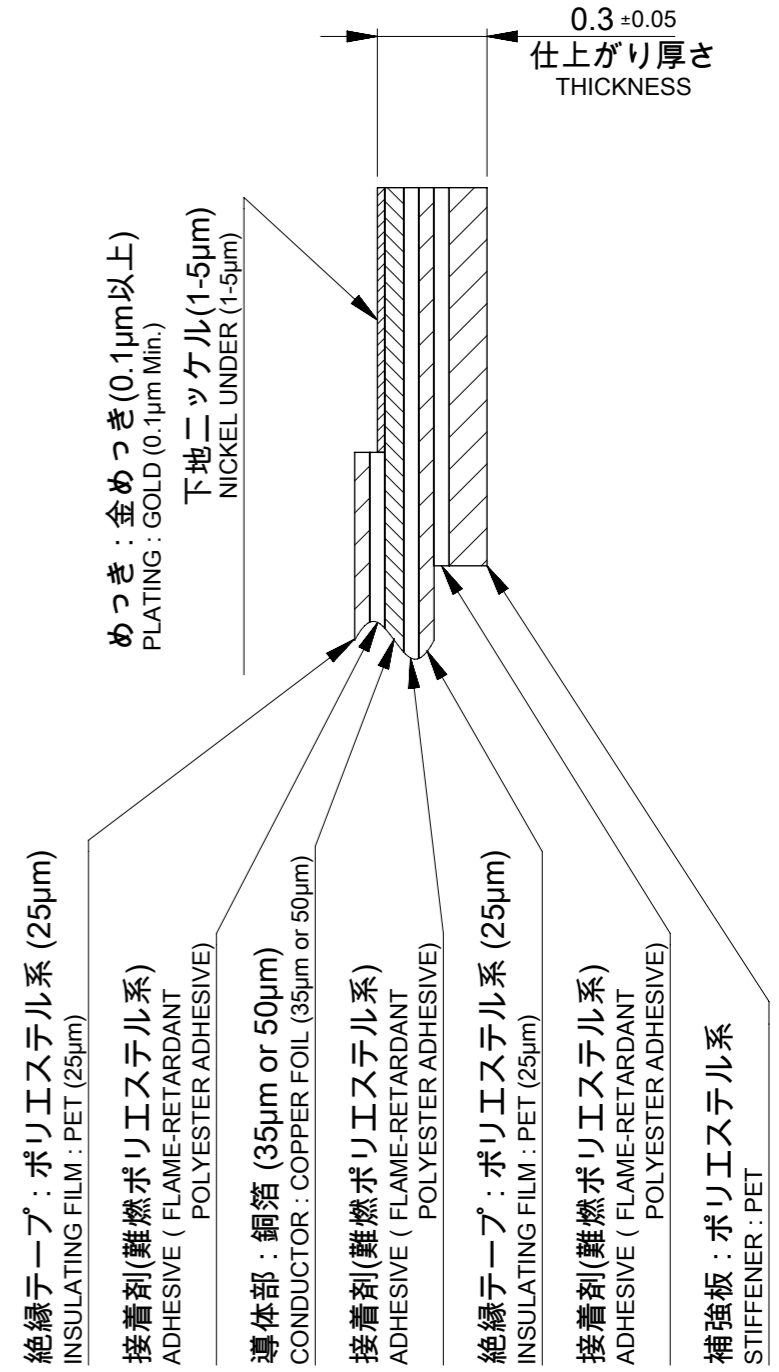

FFC構成推奨仕様  
 STRUCTURE OF FFC

THIS DRAWING CONTAINS INFORMATION THAT IS PROPRIETARY TO MOLEX ELECTRONIC TECHNOLOGIES, LLC AND SHOULD NOT BE USED WITHOUT WRITTEN PERMISSION									
DIMENSION UNITS		SCALE		CURRENT REV DESC:					
mm		10:1							
GENERAL TOLERANCES (UNLESS SPECIFIED)									
ANGULAR TOL ± 3.0°									
4 PLACES		± 0.2		EC NO: 720907					
3 PLACES		± 0.2		DRWN: RAJMOK		2022/09/21			
2 PLACES		± 0.2		CHK'D: YNUKANOBU		2022/09/22			
1 PLACE		± 0.25		APPR: YNAITO		2022/09/22			
0 PLACES		± 0.3		INITIAL REVISION:					
				DRWN: JASANUMA		2018/10/01			
				APPR: RTAKEUCHI		2018/10/10			
DRAFT WHERE APPLICABLE MUST REMAIN WITHIN DIMENSIONS				THIRD ANGLE PROJECTION		DRAWING		SERIES	
				A3-SIZE		505110			
				MATERIAL NUMBER		CUSTOMER		SHEET NUMBER	
				5051101000-SD				3 OF 4	

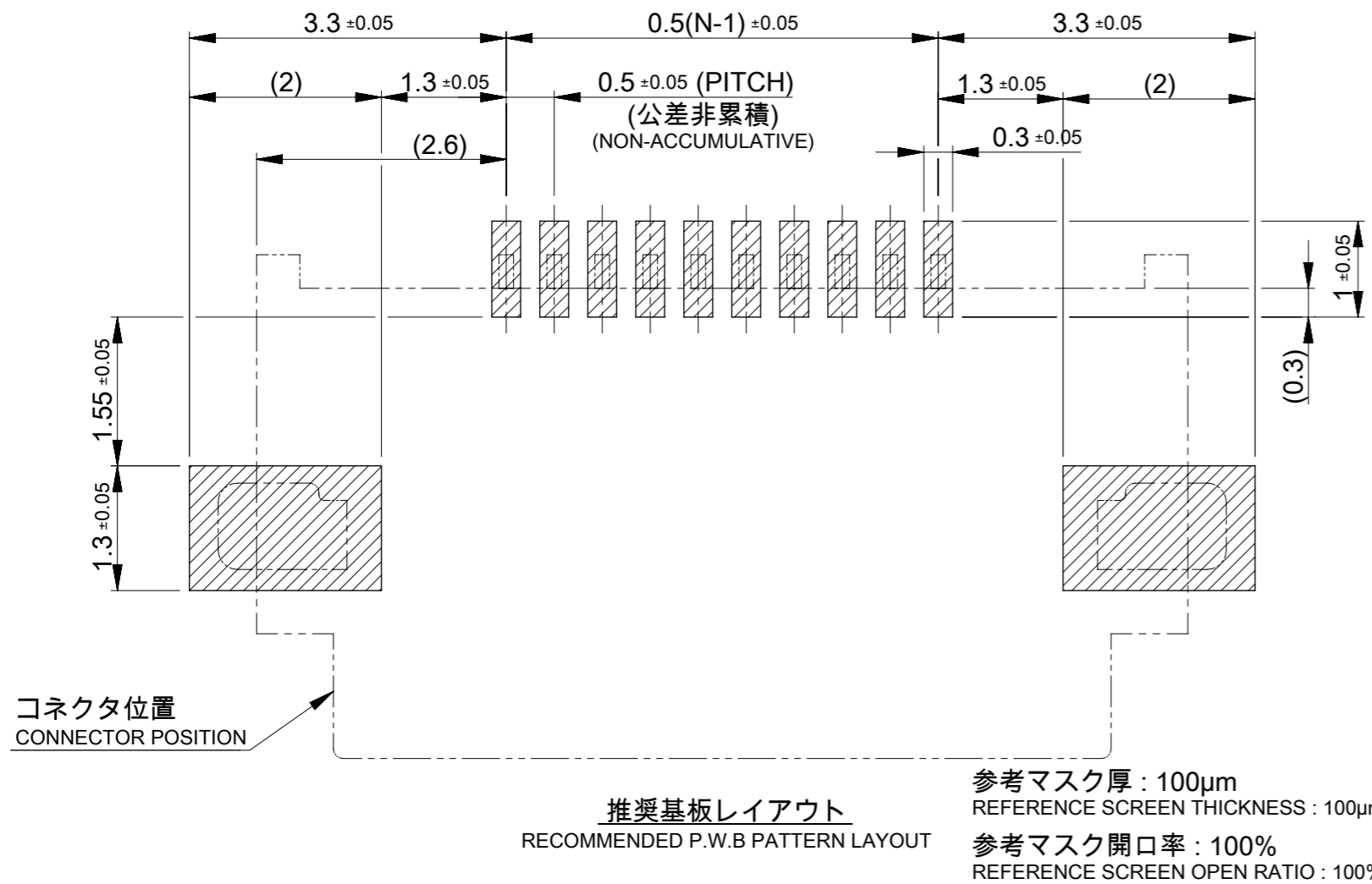

**FPC/FFCについて ABOUT FPC/FFC**

打ち抜き方向は導体側から補強板側を推奨します。  
 導体部については軟箔銅35µmまたは50µmを推奨します。  
 FFCに規定された定格温度がFFC単体前提である場合が御座います。  
 コネクタと組み合わせたの実使用において、接着層が劣化するなどの信頼性を満足できないケースを回避するため、  
 実機での評価/確認をお願いいたします。  
 RECOMMENDED PUNCHING DIRECTION : FROM CONDUCTOR SIDE TO STIFFENER SIDE  
 RECOMMENDED CONDUCTOR SPEC : SOFT COPPER FOIL  
 RECOMMENDED CONDUCTOR THICKNESS : 35 MICROMETER OR 50 MICROMETER  
 NOTE : WHEN ACTUALLY USING IT WITH CONNECTOR, PLEASE DO THE EVALUATION AND THE CONFIRMATION WITH AN ACTUAL EQUIPMENT TO EVADE THE CASE WHERE RELIABILITY CANNOT BE FILLED (THE ADHESIVE LINE OF FFC IS DETERIORATED ETC.)

**FPCについて ABOUT FPC**

補強フィルム材質はポリイミドを推奨します。ベースフィルムは25µmを推奨します。  
 接着剤は熱硬化接着剤を推奨します。  
 尚、接着剤の接点部への付着は導通不良の原因になりますので、染み出しが無い様お願い致します。  
 RECOMMENDED STIFFENER MATERIAL : POLYIMIDE  
 RECOMMENDED BASE FILM THICKNESS : 25 MICROMETER  
 RECOMMENDED ADHESIVE : THERMOSETTING ADHESIVE  
 NOTE : PLEASE PUT APPROPRIATE AMOUNT OF ADHESIVE ON ADHEREND BECAUSE THERE IS A POSSIBILITY THAT THE EXTRA ADHESIVE CAUSES THE DEFECT IN ELECTRICAL CONTINUITY.

**注記 NOTES**

1. 使用材料 MATERIAL  
 ハウジング : 液晶ポリマー ガラス充填、UL94V-0 (ベージュ)  
 HOUSING : LIQUID CRYSTAL POLYMER GLASS FILLED, UL94V-0 (BEIGE)  
 アクチュエータ : ポリアミド ガラス充填、UL94V-0 (黒)  
 ACTUATOR : POLYAMIDE GLASS FILLED, UL94V-0 (BLACK)  
 ターミナル : リン青銅 (t=0.15)  
 TERMINAL : PHOSPHOR BRONZE  
 金具 : リン青銅 (t=0.15)  
 FITTING NAIL : PHOSPHOR BRONZE
2. めっき仕様 PLATING  
 ターミナル TERMINAL  
 コントクト部 : 部分金めっき (0.05µm以上)  
 CONTACT AREA : SEPARATED GOLD PLATING (0.05µm MINIMUM)  
 テール部 : 部分金めっき  
 SOLDER TAIL AREA : SEPARATED GOLD PLATING  
 下地:ニッケルめっき (1.0µm以上)  
 UNDERPLATE : NICKEL OVERALL (1.0µm MINIMUM)  
 金具 FITTING NAIL  
 錫めっき (1.0µm以上)  
 TIN PLATING (1.0µm MINIMUM)  
 下地:ニッケルめっき (1.0µm以上)  
 UNDER PLATING : NICKEL PLATING (1.0µm MINIMUM)
3. エンボステープ梱包時は、アクチュエータが閉じた状態とする。  
 IN THE PACKAGE, ACTUATOR OF PART SHOULD BE CLOSED.
4. パターン剥離止め用金具  
 FITTING NAIL FOR PREVENTING PEELING OF P.W.B. PATTERN.
5. R0.3はFPC/FFC導体部にかからないこと。  
 R0.3 MUST NOT BE OVERLAPPED TO PATTERN OF FPC/FFC.
6. N : 極数 N : CIRCUIT
7. テールと金具を併せた平坦度は0.1mm以下とする。  
 TAILS AND NAILS COPLANALITY TO BE 0.1mm MAXIMUM.

THIS DRAWING CONTAINS INFORMATION THAT IS PROPRIETARY TO MOLEX ELECTRONIC TECHNOLOGIES, LLC AND SHOULD NOT BE USED WITHOUT WRITTEN PERMISSION									
DIMENSION UNITS		SCALE		CURRENT REV DESC:					
mm		15:1		 0.5 FPC ZIF 2 CONT HSG ASSY PRODUCT CUSTOMER DRAWING					
GENERAL TOLERANCES (UNLESS SPECIFIED)									
ANGULAR TOL ± 3.0°									
4 PLACES ± 0.2		EC NO: 720907							
3 PLACES ± 0.2		DRWN: RAJMOK 2022/09/21							
2 PLACES ± 0.2		CHK'D: YNUKANOBU 2022/09/22							
1 PLACE ± 0.25		APPR: YNAITO 2022/09/22							
0 PLACES ± 0.3		INITIAL REVISION:		DOCUMENT NUMBER		DOC TYPE		DOC PART REVISION	
DRAFT WHERE APPLICABLE MUST REMAIN WITHIN DIMENSIONS		THIRD ANGLE PROJECTION		DRAWING		SERIES		MATERIAL NUMBER	
				A3-SIZE		505110		5051101000-SD	
DOCUMENT STATUS		P1		RELEASE DATE		2022/09/22 11:54:33		PSD 000 B	
								SHEET NUMBER	
								4 OF 4	