

NOTES.

1. APPLICABLE TERMINAL : 500978\*00
2. TRADE MARK IS FORMED BY MXJ AND BY 1-2 DIGIT NUMBER (TO CAVITY NO.) AND BY 1 LETTER OD ALPHABET (TO MOLD NO.)
3. ELV AND RoHS COMPLIANT

(NON-ACCUMULATIVE)

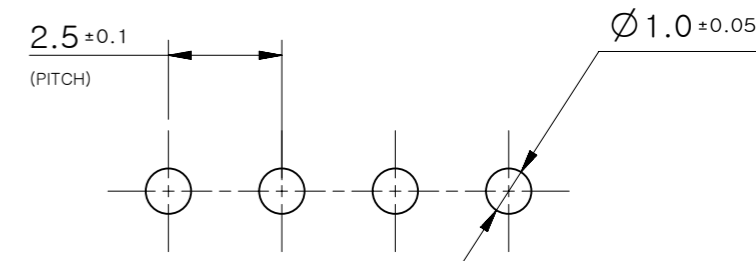

RECOMMENDED PC BOARD HOLE DIMENSION  
(THICKNESS : 1.6mm)

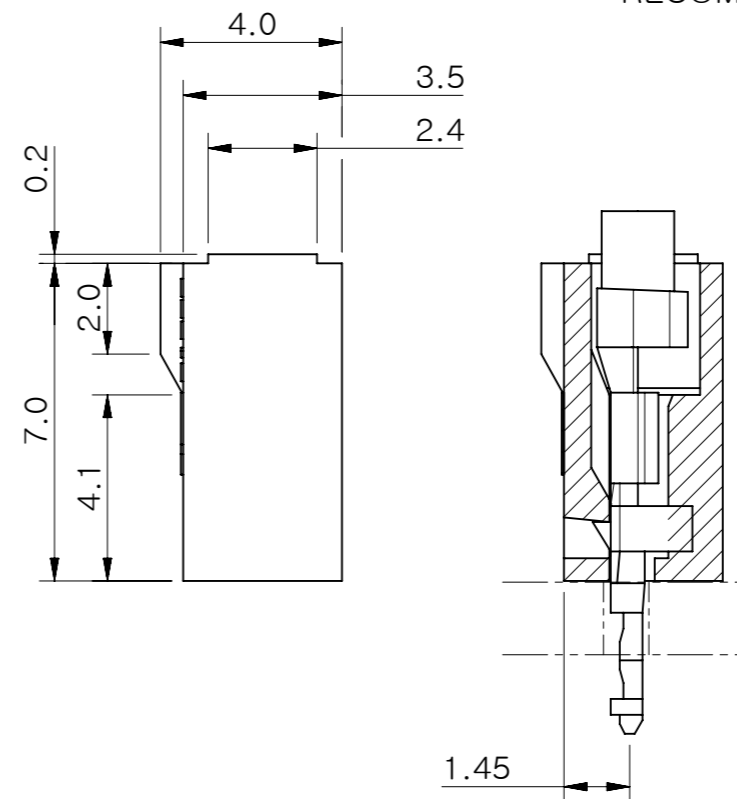

SECTION A-A

勝特力電材超市-龍山店 886-3-5773766  
 勝特力電材超市-光復店 886-3-5729570  
 勝特力電子(上海) 86-21-34970699  
 勝特力電子(深圳) 86-755-83298787  
<http://www.100y.com.tw>

27.5	30.7	510351200	12
25.0	28.2	510351100	11
22.5	25.7	510351000	10
20.0	23.2	510350900	9
17.5	20.7	510350800	8
15.0	18.2	510350700	7
12.5	15.7	510350600	6
10.0	13.2	510350500	5
7.5	10.7	510350400	4
5.0	8.2	510350300	3
2.5	5.7	510350200	2
B	A	ORDER NO.	CKT.

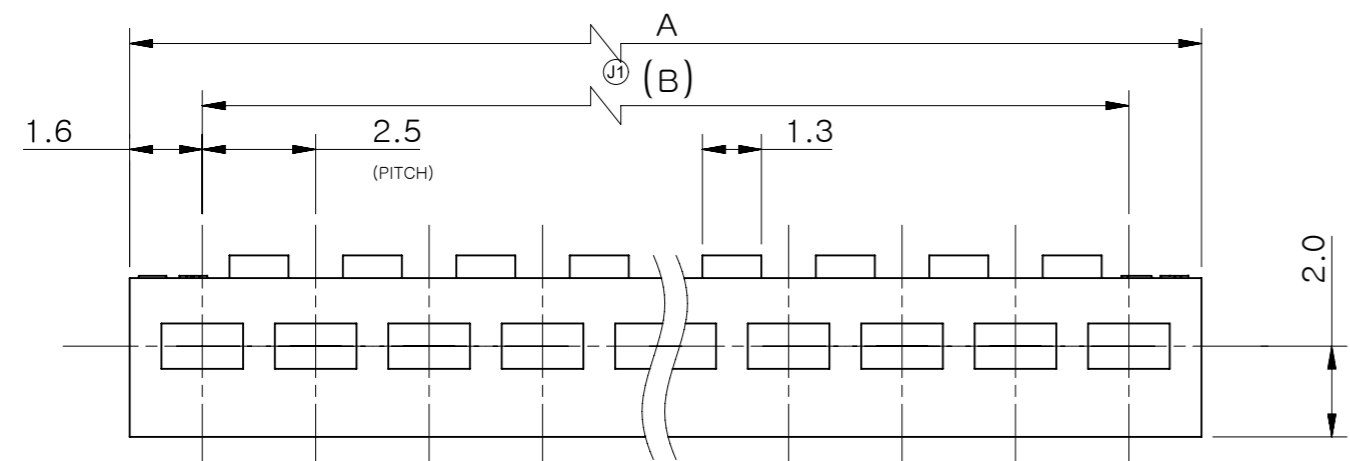
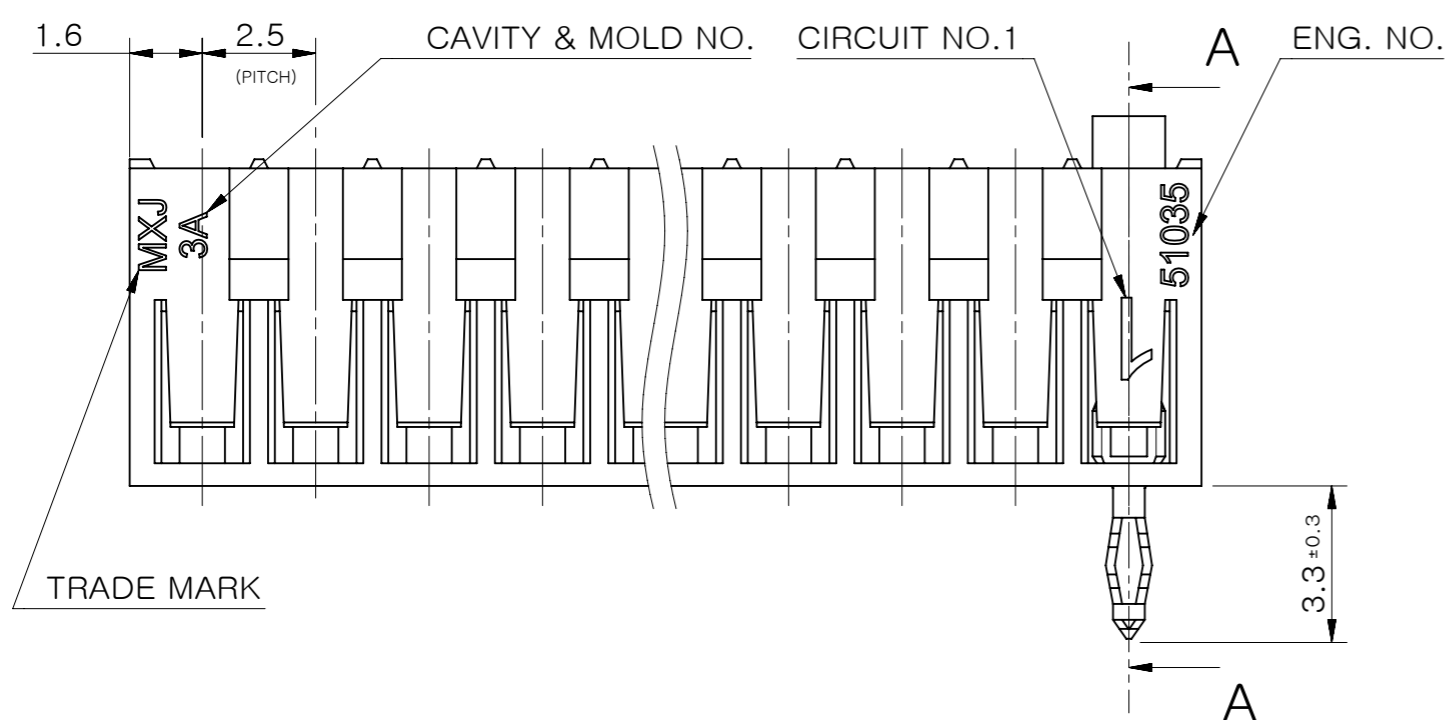
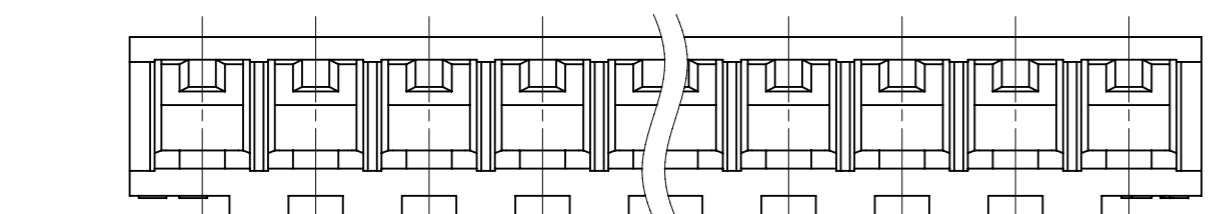

GENERAL TOLERANCES (UNLESS SPECIFIED)	
10 UNDER	±0.2
10 OVER 30 UNDER	±0.25
30 OVER	±0.3
DRAFT WHERE APPLICABLE MUST REMAIN WITHIN DEMENSIONS	

MATERIAL	POLYAMIDE, UL94V-0
WIRE RANGE	AWG #24 ~ 20 KV 0.2 ~ 0.5 AVS 0.3 ~ 0.5
INS. RANGE	Ø1.3 ~ Ø2.1

FUNCTIONAL SYMBOLS	THIS DRAWING CONTAINS INFORMATION THAT IS PROPRIETARY TO MOLEX ELECTRONIC TECHNOLOGIES, LLC AND SHOULD NOT BE USED WITHOUT WRITTEN PERMISSION
SCALE	6:1
GENERAL TOLERANCES (UNLESS SPECIFIED)	ANGULAR TOL ± 3.0°
DIVISIONAL SYMBOLS	EC NO: 704776 DRWN: SUGEEB CHK'D: GGA APPR: GGA
INITIAL REVISION:	2022/03/31 2022/05/24 2022/05/24
THIRD ANGLE PROJECTION	DRWING: RHORI APPR: NUKITA
DRAFT WHERE APPLICABLE MUST REMAIN WITHIN DIMENSIONS	2011/05/12 2011/05/16
<b>molex</b>	
2.5 BOARD IN CONN. HOUSING	
PRODUCT CUSTOMER DRAWING	
DOCUMENT NUMBER	DOC TYPE DOC PART REVISION
SD-51035-001	PSD 001 J2
MATERIAL NUMBER	CUSTOMER
SEE TABLE	GENERAL MARKET
SHEET NUMBER	1 OF 1



产品编号 : [510350500](#)

Product Description : 2.50mm Pitch, Board-In Crimp Housing, Single Row, 5 Circuits, Natural

系列号 : 51035

状态 : Active

Product Category : Connector Housings

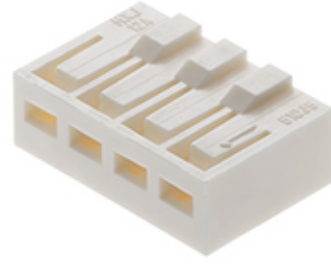

---

## 文件和资源

### 图纸

[图纸 510350500\\_sd.pdf](#)

[包装设计图 SPK-51035-001-001.pdf](#)

[包装设计图 SPK-51035-001-002.pdf](#)

### 3D 模型和设计文件

[3D模型 510350500\\_stp.zip](#)

### 规格

[产品规格 PS-51035-001-001.pdf](#)

[产品规格 PS-51035-002-001.pdf](#)

---

## 产物环境合规

### 合规

GADSL/IMDS	Not Relevant
China RoHS	
EU ELV	Not Relevant
Low-Halogen Status	Not Low-Halogen per IEC 61249-2-21
REACH SVHC	Not Contained per D(2023)3788-DC (14 Jun 2023)
EU RoHS	Compliant per EU 2015/863

### 多部分产品合规性声明

- Eu RoHS
- REACH SVHC
- Low-Halogen

### 多部分行业合规性文件

- IPC 1752A Class C
- IPC 1752A Class D
- Molex Product Compliance Declaration
- IEC-62474
- chemSHERPA (xml)

欧盟 RoHS 合格证书

## 产品详情

### 常规

状态	活动
类别	Connector Housings
系列	51035
说明	2.50mm Pitch, Board-In Crimp Housing, Single Row, 5 Circuits, Natural
应用	Signal
产品系列	Board-in Connectors
产品名称	Board-in
UPC	800754298582

### 物理

电路数（最多）	5
颜色-树脂	Natural
性别	不适用
符合灼热丝规范	否
材料 - 树脂	Nylon
净重	228.100/mg
行数	1
包装形式	Bag
面板安装式	否
间距 - 插配接口	2.50mm
可堆叠的	否
运行温度范围	-40° to +105° C

可连接使用部件

描述	产品编号
2.50mm Pitch Board-in Male Crimp Terminals	<u>50097</u>

---

This document was generated on Dec 11, 2023