



Revised:
March 2011

Hand Tools

Europe, the Middle East and Africa

and associated equipment

(Internet download)

勝特力材料 886-3-5753170
勝特力电子(上海) 86-21-34970699
勝特力电子(深圳) 86-755-83298787
[Http://www.100y.com.tw](http://www.100y.com.tw)



Introduction

Tyco Electronics recommends that hand powered tools are used only for repair or very low volume production use. Care must be taken not to use these types of tools continuously for prolonged periods as RSI (repetitive strain injury) may result. Tyco Electronics provides a wide range of powered equipment options where medium to high volumes are anticipated.

What you need to know about Terminals

Loose Piece

For a Terminal to be suitable for use in a hand tool it must be cut from the carrier strip it is manufactured on, and more importantly pre-formed.

We call this the loose piece (LP) version - this may have the same / different base PN and / or dash number than the strip version.

Pre-forming allows the short stroke of a hand tool to work and helps stabilise the terminal within the tool and form correctly during crimping.

Terminal Types

Terminal type descriptions are very general and can be misleading if solely used to identify suitable tooling. It is strongly recommended that when searching for a tool for your application, you establish and use a specific Loose piece PN.

Terminal Wire Range

Each Terminal will have a specific wire range, this may be different for different dash numbers of the same base PN.

This will determine which wire / tool combinations that can be used with the terminal.

What you need to know about Hand Tools

The procedures in the relevant Instruction Sheet must be followed to achieve optimum crimp results.

Tool Grade

A prime consideration when choosing the appropriate tool for an application.

Our hand tools are categorised into three levels; Service, Commercial and Premium, each level requiring less operator skill respectively so that the specified crimp parameters are met repeatedly.

Service tools rely heavily on operator skill to ensure that terminal and wire are correctly positioned correctly and that the specified crimp height is achieved repeatedly.

Commercial tools rely on some operator skill to ensure that terminal and wire are correctly positioned, but have a ratchet or certi-crimp mechanism to ensure that the specified crimp height is achieved repeatedly.

Premium tools have terminal and wire positioning aids built in, along with a ratchet or certi-crimp mechanism to best ensure that all of the specified crimp parameters are met repeatedly.

Wire Range

The overall wire range is also a prime consideration when choosing the appropriate tool for an application. Often there will be several tools referenced to the same product but having different wire ranges.

Tool Type

Choosing a tool type maybe driven by several factors; simply by type preference, or by the application needs itself ie a heavy duty crimp, industry specification requirements etc.

Choosing the right tool

1. Enter your Terminal PN into the search.
2. Establish the wire sizes that you want to use within the terminal(s) wire range.
3. Check the db for the tool options available for your PN - Nothing available? Then contact your nearest PIC.
4. Choose a tool based on; tool type, wire range and tool grade that best suits your application.

SDE Equipment

Equipment Type	Page
Die-set - SDE (shoulder)	8
Die-set - SDE (pin)	9
SDE PRO-CRIMPER III	10
SDE DA Hand Tool	10
Die-set - SDE SA	11
SDE SA	12
Die-set - SDE Premium	12
SDE 626 Pneumatic	13
SDE Electric Terminator	13

General Hand Tool Types

Equipment Type	Page
CERTI-CRIMP II SAHT	14
CERTI-CRIMP II SAHT - Short Handle	15
CERTI-CRIMP II SAHT - Long Handle	15
CERTI-CRIMP II SAHT - Head Assy	16
Double Action Hand Tool	17
Adapter - Double Action Hand Tool to 626 Pneumatic	18
Head only - Double Action Hand Tool	18
C-Head SAHT	19
C-Head SAHT - LD	19
Die-set - C-Head SAHT	20
Die-set - C-Head SAHT - HD	20
Heavy Head Hand Tool	21
Heavy Head Hand Tool - Head Assy	22
Adapter - Heavy Head to 626 Pneumatic	22
Reel-Fed CERTI-LOK	23
CERTI-LOK	23
Adapter - CERTI-LOK to Electric Terminator	23
PEZ 100	24
ERGOCRIMP	24
Tetra-Crimp Hand Tool	24
Mini CERTI-LOK	25
Modular Mini CERTI-LOK	25
C-Frame Hand Tool	25
D-Frame Tool	26
Trapezium Crimp Tool	26
Square Crimp Tool	27
Service Tool	27
TERMI-POINT Service Tool	27
TERMI-POINT Hand Tool	28
Service Kit Tool	29
Die-set - Service Kit Tool	29

Hand Tools for IDC Applications

Equipment Type	Page
Pistol Grip	30
Pistol Grip II	31
Pistol Grip III	31
Special Hand Tool for DUOPLUG 2.5	32
Hand Tool - ANSLEY 779-2100	32

Insertion / Extraction Tool Types

Equipment Type	Page
Standard Extraction Tool	33
Extraction Tool	34
Standard Insertion Tool	35
Insertion Tool	35
Tee Handled Insertion Tool	36
Insertion / Extraction Tool Kit	36

Heavy Duty Crimp Equipment & Accessories

Equipment Type	Page
ROTA-CRIMP Hand Tool	37
Bantam ROTA-CRIMP Hand Tool	37
Hydraulic Hand Tool - SOLISTRAND	37
Hydraulic Head - SOLISTRAND	38
Cable Cutter - Battery-Hydraulic Tool 100 KN	38
'U' Die Assy	39
'U' Die Assy (14 ton)	40
'U' Die Nest	41
'U' Die Indenter	42
'U' Die 12 Ton Hydraulic Hand Tool	42
'U' Die 14 Ton Hydraulic Hand Tool	43
'U' Die 12 Ton Hydraulic Head	43
Battery-Hydraulic Tool Kit - 12 Ton 'U' Die	43
'U' Die 14 Ton Hydraulic Head	44
'U' Die 14 Ton Hydraulic Head - Latched	44
Dies for Battery Tool Kit - 4 Ton Latch Head	45
Battery Tool Kit - 4 Ton Latch Head	45
Die-set - Hydraulic Head Open (Shank Die)	46
Hydraulic Head Open (Shank Die)	47
Hydraulic Head Open - Dyna-Crimp	47
Die-set - Hydraulic Head Closed (Shank Die)	48
Hydraulic Head Closed (Shank Die)	48
Hydraulic Head Closed - Dyna-Crimp	49
Die-set - Hydraulic Head Open (Shank Die H'Duty)	49
Hydraulic Head Open (Shank Die Heavy Duty)	50
Hydraulic Head Open (Heavy Duty) - Dyna-Crimp	50
Die-set - Hydraulic Head Closed (Shank Die H'Duty)	50
Hydraulic Head Closed (Shank Die Heavy Duty)	51
Hydraulic Head Closed (Heavy duty) - Dyna-Crimp	51
Battery-Hydraulic Tool 100 KN	52
Heavy duty Electric Hydraulic Pump	53
Electric Hydraulic Pump, light duty	53
Hydraulic Hand Pump	53
Hydraulic Foot Pump	54
Group Cutter	54
Cable Cutter 350 mcm	54
Cable Cutter 500 mcm	55
Cable Cutter 350 mcm with Ratchet	55
Cable Cutter 500 mcm with Ratchet	55
Cable Cutters SH Range	56

Contractor Tools

Equipment Type	Page
Corex Coax Stripper	57
JackKnack	57
Coax Cable Stripper	58
Rotary Cable Stripper	58
Automatic Wire Stripper	58
Die-cast Automatic Wire Stripper	59
Small Wire Cutters	59
KT 80 Cutting Tool	59
Cable Tie Gun	60
Non-impact Punch-down Tool	60
Impact Punch-down Tool	60
Premium Impact Punch-down Tool	61
Professional Hand Tool	61
Mod Jack Tool	62
Crimping Kit for Modular Plugs	62
Tone Generator	63
Tone Tracer	63
4-Pair Tester	63
SUPER CHAMP II	64
SUPER CHAMP FT	64
CRIMPAC CG	65
Die-set - SDE for Fibre Optic Connectors	65
Dual Purpose Butterfly Tool	65

Tools for Screw-machined Contacts

Equipment Type	Page
AF8	66
AF8 - Turret	66
AFM8	67
AFM8 - Positioner	67
FT8	68
M300 BT	68
M309	68
M310	69
M317	69
MH860	70
HX4	70
ERGOCRIMP - Chrome	71
Hydraulic Hand Tool 30 KN	71
Hydraulic Hand Tool 60 KN	72

Industry / Product specific kits

Equipment Type	Page
Ampliset repair Kit	73
Service Kit - SUPERCHAMP II	73
Service Kit - CRIMPAC CG	73
Universal Service Tool Kit	74
Starter Kit	74
Installers Kit	75
Pistol Grip tool kit for 2mm FB + HM	75
Pistol Grip Kit for RV-100	75
VS-3 Hand Tool Kit	76
VS-3 Hand Tool Holder	76

Telecoms and Outside Plant

Equipment Type	Page
10 Pair Splicing Kit	77
25 Pair Splicing Kit	78
Crimping Pliers	78
Double Point Electrical Tester	79
Single Point Insertion Tool	79
10 Pair Separator Tool	79
Check Combe, 10 pair	80
Check Combe, 25 pair	80
Single Point Separator Tool	80
Splicing Head, 10 Pair with Pedestal Bar, 10 Pair	81
Splicing Head, 10 Pair	81
Splicing Head, 25 Pair	81

Power Assist options

Equipment Type	Page
BT 3500 Battery-Hydraulic Hand Tool	82
Electric Terminator EU	82
Micro Pneumatic	83
Micro Pneumatic Adapter	83
Micro Pneumatic Crimping Head	83
626 Pneumatic	84
626 Pneumatic Adapter	84
626 Pneumatic Crimping Head (Small Tool Holder)	84
626 Pneumatic Crimping Head (Large Tool Holder)	85
Bench Press AT-SC	85

Die-set - SDE (shoulder)

Predominately used on closed-barrel terminals.
 These Dies are ideally suited to R&D prototyping, networking, commercial & industrial and all manor of maintenace applications.

Image representative of type only

Features:

Use in:

SDE PRO-CRIMPER III Hand Tool 354940-1

SDE SA Hand Tool 9-1478240-0

SDE DA Hand Tool 1213745-1

SDE BT 3500 Battery-Hydraulic Hand Tools:

2-2031400-1 - EMEA or 3-2031400-1 - UK

+ SDE Head 2031450-1

SDE 626 Head 679304-1 + accessories

SDE Electric Terminator 1490076-2

SDE Bench Press AT-SC 528050-1

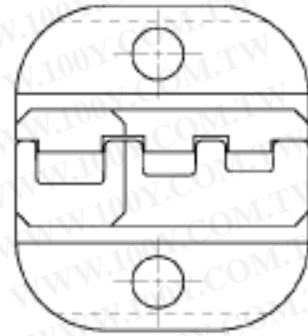

Part Number	Description	mm ² (AWG) or other
58436-1	50Ω BNC & TNC - Hex Crimp	RG 58, 62, 59
58509-1	BUDGET SOLISTRAND	0.4 - 6.0 (22-10)
58573-2	Spare Wire Cap	0.15 - 6.0 (26-10)
91902-1	Coax - N Series	RG 141
58436-3	Coax	RG 174, 188, 316, 179, 161, 187
1424050-1	Coax	RG 174, 188
58536-1	Coax	RG 71 B
58485-1	Coax - Hex COMMercial	RG, 8,9,11,213,214,216
58560-2	MODULAR PLUG connectors	10 Posn
790163-6	MODULAR PLUG - 8 Posn	
790163-4	MODULAR PLUG - 8 Posn Shielded	CAT 6 5.40 hex 5.6 lg
224928-2	MODULAR PLUG - 8 Posn, strain relief	Ø4.70 - 5.76 Ins. Ø0.19-0.22mm
790163-2	Modular Plug 8 Position Shielded	0.15 - 0.2 (26-24) CAT 6
91911-3	MULTI-MATE - Submin	RG 174
58424-1	Optimate ST	Cable Dia 3 mm
58423-1	PIDG, PLASTI-GRIP - RBY All Types including PIDG FASTON Flag 22-18 & 16-14	0.4 - 6.0 (22-10)
58545-1	SOLISTRAND Terminals & Splices	0.4 - 6.0 (22-10)

Die-set - SDE (pin)

Predominately used on open-barrel terminals.

These Dies are ideally suited to R&D prototyping, networking, commercial & industrial and all manor of maintenace applications.

Image representative of type only

Features:

Use in:

SDE PRO-CRIMPER III Hand Tool 354940-1

SDE SA Hand Tool 9-1478240-0

SDE DA Hand Tool 1213745-1

SDE BT 3500 Battery-Hydraulic Hand Tools:

2-2031400-1 - EMEA or 3-2031400-1 - UK

+ SDE Head 2031460-1

SDE 626 Head 679304-1 + accessories

SDE Electric Terminator 1490076-2

SDE Bench Press AT-SC 528050-1

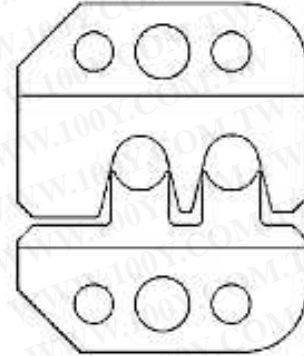

Part Number	Description	mm ² (AWG) or other
91387-2	4.2 PE series	0.15 - 0.4 (26-22)
91388-2	4.2 PE Series	0.4 - 1.0 (22-18)
1891358-1	AMP EI Receptacle	0.15 - 0.6 (26-20)
58641-2	AMP MOD IV, V	0.15 - 0.4 (26-22)
58448-3	AMPLIMITE HD-20	[28-20]
90800-2	AMPLIMITE HD-22	0.08 - 0.4 (28-22)
217212-2	Closed End Splice	1.0 - 6.0 (18-10)
90872-2	COMM 0.93 mm	0.2 - 1.0 (24-18)
90574-2	Commercial MATE-N-LOK	0.2 - 0.96 (24-18)
90575-2	Commercial MATE-N-LOK	0.6 - 2.5 (20-14)
58517-2	CST-100	0.15 - 0.4 (26-22)
58548-2	EI Receptacle	0.15 - 0.6 (26-20)
58652-2	FASTON 2.8 (.110) Receptacle	0.6 - 1.5 (20-16)
58524-2	FASTON 6.3 [.250] Receptacle	1.0 - 2.5 (18-14)
91304-2	Junior Power TIMER 2.8 (SWS) & Micro TIMER	0.5 - 1.0 (20-18)
58603-2	Junior Power TIMER; TAB 2.8	0.75 - 2.5 (20-14)
1752938-2	MATE-N-LOK 3.5 (.140)	0.75 - 1.64 (18-16)
90760-2	Mini Universal MATE-N-LOK	[20-16]
90759-2	Mini Universal MATE-N-LOK	[22-18]
90758-2	Mini Universal MATE-N-LOK	0.15 - 0.4 (26-22)
58707-2	Mini-Universal MATE-N-LOK	0.6 - 1.5 (20-16)
58522-2	MULTILOCK 040	0.4 - 0.6 (22-20)
90652-2	MULTILOCK 040 MkII	0.4 - 1.0 (22-18)
90653-2	MULTILOCK 070	0.4 - 0.6 (22-20)
58606-2	Pin/Socket Ø1.5 & Ø2.5 (SWS)	1.0 - 2.5 (18-14)
58593-2	Power Quadlock	1.5 - 3.0 (16-14)
58594-2	Power Quadlock	4.0 (12)
58595-2	Power Quadlock (SWS)	1.5 - 2.5 (16-14)
58596-2	Power Quadlock (SWS)	4.0 (12)
58614-2	SL-156	0.2 - 1.0 (24-18)
58583-2	SUPERSEAL 1.5 series	0.5 - 1.0 (20-18)
58495-2	TYPE III+; TYPE VI	0.08 - 1.5 (28-16)
58628-2	ULTRA FAST (excluding Flag Terminals)	0.15 - 2.5 (26-14)
58630-2	ULTRA FAST	4.0 - 6.0 (12-10)
90546-2	Universal MATE-N-LOK	0.5 - 2.1 (20-14) Ins. Ø1.53-3.30 mm
90547-2	Universal MATE-N-LOK	0.5 - 2.1 (20-14) Ins. Ø3.30-5.08mm

SDE PRO-CRIMPER III

354940-1 - Base Tool without Die-set

An alternative to SDE PEW 12 & SDE DA hand tools, but with different features and a different geometry

Image representative of type only

Features:

Accepts all SDE Shoulder & Pin Dies

Ratchet mechanism ensures complete crimp cycle

Emergency ratchet release feature

Ergonomic non-slip handles

Approximate weight 0.59 kg (1.3 lbs)



Part Number	Description	mm ² (AWG) or other
58448-2	AMPLIMITE HD-20	[28-20]
90800-1	AMPLIMITE HD-22	0.08 - 0.4 (28-22)
90760-1	Mini Universal MATE-N-LOK	[20-16]
90759-1	Mini Universal MATE-N-LOK	[22-18]
790163-3	MODULAR PLUG - 8 Posn Shielded	CAT 6 5.40 hex 5.6 lg
790163-1	Modular Plug 8 Position Shielded	0.15 - 0.2 (26-24)
58433-3	PIDG, PLASTI-GRIP - RBY All Types including PIDG FASTON Flag 22-18 & 16-14	0.4 - 6.0 (22-10)
58593-1	Power Quadlock	1.5 - 3.0 (16-14)
58594-1	Power Quadlock	4.0 (12)
58595-1	Power Quadlock (SWS)	1.5 - 2.5 (16-14)
58596-1	Power Quadlock (SWS)	4.0 (12)
58546-1	SOLISTRAND Terminals & Splices	0.4 - 6.0 (22-10)
58546-2	SOLISTRAND Terminals & Splices	0.4 - 6.0 (22-10)

SDE DA Hand Tool

1213745-1 - Base Tool without Die-set

Designed specifically for closed barrel applications.

Image representative of type only

Features:

Accepts all SDE Shoulder & Pin Dies

High mechanical advantage for enhanced user comfort

Ratchet mechanism ensures complete crimp cycle

Emergency ratchet release feature

Ergonomic non-slip handles

Approximate weight 0.59 kg (1.3 lbs)



Die-set - SDE SA

These dies can have up to five crimp positions and are NOT suitable for use in the SDE Procrimper III Hand Tool

Image representative of type only

Features:

Use in:

SDE SA Hand Tool 9-1478240-0

SDE BT 3500 Battery-Hydraulic Hand Tools:

2-2031400-1 - EMEA or 3-2031400-1 - UK

+ SDE Head 2031450-1

SDE 626 Head 679304-1 + accessories

SDE Electric Terminator 1490076-2

SDE Bench Press AT-SC 528050-1

(not for use in SDE PRO-CRIMPER III Hand Tool 354940-1)



Part Number	Description	mm ² (AWG) or other
9-1478247-0	Coax - GREENPAR	BT2003
9-1478243-0	Coax - GREENPAR	PSF 1/2M, Belden 8281, TM 3205
9-1478248-0	Coax - GREENPAR	RG 174, 178, 188... See 408-8698
9-1478245-0	Coax - GREENPAR	RG 174, 179, 187... see 408-8694
9-1478242-0	Coax - GREENPAR	RG 55, 58, 59, 62... see 408-8694
9-1478246-0	Coax - GREENPAR	RG 9, 58, 141... see 408-8694
2063583-2	HTS: HE/HA; HN D; HVT Contacts	0.14 - 4.0
2063041-2	Micro Quadlok	0.25 - 0.5 (24-22)
2063030-1	PIDG, PLASTI-GRIP Terminals & Splices with Terminal Locator	0.4 - 6.0 (22-10)
2031973-2	Universal MATE-N-LOK	0.2 - 2.0 Ins. Ø1.0-3.3mm
2063379-2	Universal MATE-N-LOK	0.5 - 2.0 Ins. Ø1.4-2.4mm

SDE SA

9-1478240-0 - Base Tool without Die-set
 An alternative to PRO-CRIMPER III & SDE DA hand tools, but with different features and a different geometry

Image representative of type only

Features:

- Accepts all SDE; Shoulder, Pin & Plus Dies
- Ratchet mechanism ensures complete crimp cycle
- Virtually a straight action jaw closure
- Easy access ratchet release
- Handle pressure adjustment with locking device
- Ergonomic non-slip handles
- Approximate weight 0.59 kg (1.3 lbs)



Part Number	Description	mm ² (AWG) or other
9-1478239-0	Coax - GREENPAR	RG 8, 213... See 408-8695
2063583-1	HTS: HE/HA; HN D; HVT Contacts	0.14 - 4.0
1752938-1	MATE-N-LOK 3.5 (.140)	0.75 - 1.64 (18-16)
91391-1	Micro MATE-N-LOK	0.06 - 0.5 (30-20)
2063041-1	Micro Quadlok	0.25 - 0.5 (24-22)
2031973-1	Universal MATE-N-LOK	0.2 - 2.0 Ins. Ø1.0-3.3mm
2063379-1	Universal MATE-N-LOK	0.5 - 2.0 Ins. Ø1.4-2.4mm

Die-set - SDE Premium

These dies are based on the Double Action Hand Tools used in Aerospace & Military applications.

Image representative of type only

Features:

- Insulation crimp height adjustment
- Terminal locator & wire stop

Use in:

- SDE BT 3500 Battery-Hydraulic Hand Tools:
 - 2-2031400-1 - EMEA or 3-2031400-1 - UK
 - + SDE Head 2031460-1
- SDE Electric Terminator 1490076-2

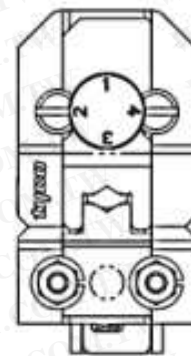

Note: The Specifications shown against the Dies listed are only applicable when using terminals and wires recommended for the relevant industry

Part Number	Description	mm ² (AWG) or other
91964-2	PIDG, PLASTI-GRIP Terminals & Splices - equivalent crimp to 47386 Qualified; Mil-T-7928; LUL RSE 024 pt6 & EE6161 Marks the applied product with a two dot indent code.	0.4 - 1.5 (22-16)
91963-2	PIDG, PLASTI-GRIP Terminals & Splices - equivalent crimp to 47387 Qualified; Mil-T-7928; LUL RSE 024 pt6 & EE6161 Marks the applied product with a two dot indent code.	1.5 - 2.5 (16-14) 0.6 - 1.5 (20-16) HD
91965-2	PIDG, PLASTI-GRIP Terminals & Splices - equivalent crimp to 59239-4 Qualified; Mil-T-7928; LUL RSE 024 pt6 & EE6161 Marks the applied product with a two dot indent code.	4.0 - 6.0 (12-10)

SDE 626 Pneumatic

Ideal for low to medium production volumes.

Features:

Accepts any Pin / Shoulder SDE Die-sets
All pneumatic

Includes:

Head 679304-1
Tool Holder with Ratchet 356302-1
Hand held power unit 189721-1

Option to convert to Bench mount:

Bench-mount 856402-1
Foot Actuated Power Unit 189722-1

for more 626 options please see the Power Assist section

Image representative of type only



Part Number	Description	mm ² (AWG) or other
1213855-1	SDE 626 Pneumatic for SDE Pin & Shoulder dies	4.0 - 6.0 (12-10)

SDE Electric Terminator

1490076-2 - Portable Bench-top Unit with SDE Head & Foot Switch

Features:

Ideal for low to medium production volumes.
Accepts any SDE Die-set
Mains powered unit - no air required
Switchable 110v or 240v supply
Cycle Counter
Two stage crimp cycle option

Image representative of type only



for other SDE Power Options please see the Power Assist section

CERTI-CRIMP II SAHT

Standard Straight Action Hand Tool Design
 Widely used in the Aircraft and Military industries

Image representative of type only

Features:

- Fixed dies
- Straight action jaw closure
- Ratchet mechanism ensures complete crimp cycle
- Emergency only ratchet release
- Terminal/wire positioning aids & Ins. adjustment on most tools
- Ergonomic non-slip handles
- Approximate weight 0.59 kg (1.3 lbs)



Part Number	Description	mm ² (AWG) or other
91572-1	AMP CT 2.0 Receptacle	0.12 - 0.4 (26-22)
91576-1	AMP DYNAMIC D-2	0.08 - 0.22 (28-24)
91595-1	AMP DYNAMIC D-2	0.4 - 1.0 (22-18)
91559-1	AMP DYNAMIC D-3	0.2 - 0.6 (24-20)
91558-1	AMP DYNAMIC D-3	0.6 - 1.5 (20-16)
91537-1	AMP MOD II FFC	0.15 - 0.4 (26-22)
91516-1	AMP MOD IV	0.05 - 0.6 (30-20)
91517-1	AMP MOD IV, V	0.15 - 0.4 (26-22)
91549-1	AMPLIMITE HD-20	0.08 - 0.22 (28-24)
91503-1	AMPLIMITE HD-20	0.08 - 0.6 (28-20)
91548-1	AMPLIMITE HD-20	0.08 - 0.6 (28-20) No Ins. Crimp
91525-1	AMPLIMITE HD-20	0.15 - 0.4 (26-22)
91513-1	AMPLIMITE HD-20	0.4 - 1.0 (22-18) No Ins. Crimp
91520-1	AMPLIMITE HD-22	0.08 - 0.4 (28-22)
91512-1	Commercial MATE-N-LOK	0.2 - 0.96 (24-18) Ins. Ø1.52-2.54mm
91504-1	Commercial MATE-N-LOK	0.6 - 2.5 (20-14)
1901963-1	MATE-N-LOK 3.5 (.140)	0.5 - 2.1 (20-14)
91502-1	Micro MATE-N-LOK	0.05 - 0.12 (30-26)
91501-1	Micro MATE-N-LOK	0.2 - 0.6 (24-20)
91540-1	Mini Tandem-Spring Pin	0.03 - 0.4 (32-22)
91536-1	Mini-Universal MATE-N-LOK "F" Ins. Crimp	[20-16]
91529-1	Mini-Universal MATE-N-LOK	0.15 - 0.4 (26-22)
91522-1	Mini-Universal MATE-N-LOK	0.4 - 1.0 (22-18)
91594-1	Mini-Universal MATE-N-LOK, type "O" Ins. Crimp	0.5 - 1.42 (20-16)
91577-1	MULTILOCK 040	0.4 - 0.6 (22-20)
91588-1	MULTILOCK 040 MkII	0.6 - 1.0 (20-18)
91542-1	TYPE III+	0.2 - 0.6 (24-20)
91505-1	TYPE III+	0.2 - 1.42 (24-16) Ins. Ø1.14-2.54mm
91523-1	TYPE III+	0.2 - 1.5 (24-16) Ins. Ø2.03-2.54mm
91521-1	TYPE III+	1.0 - 2.5 (18-14)
91515-1	TYPE III+, Type VI; Commercial MATE-N-LOK	0.05 - 0.6 (30-20)
91510-1	Universal MATE-N-LOK	0.2 - 0.96 (24-18)
91506-1	Universal MATE-N-LOK	1.2 - 2.1 (16-14) Ins. Ø3.30-5.08mm

CERTI-CRIMP II SAHT - Short Handle

Ideal for working in confined spaces
Widely used in the Aircraft and Military industries

Image representative of type only

Features:

- Fixed dies
- Straight action jaw closure
- Ratchet mechanism ensures complete crimp cycle
- Emergency only ratchet release
- Terminal/wire positioning aids & Ins. adjustment on most tools
- Ergonomic non-slip handles
- Approximate weight 0.5 kg (1.1 lbs)



Part Number	Description	mm ² (AWG) or other
1901611-2	PIDG STRATO-THERM Terminals & Splices	0.2 - 0.6 (24-20)
1901600-2	PIDG STRATO-THERM Terminals & Splices	1.0 - 1.5 (18-16)

CERTI-CRIMP II SAHT - Long Handle

Low handle force for ease of operation
Widely used in the Aircraft and Military industries

Image representative of type only

Features:

- Fixed dies
- Straight action jaw closure
- Ratchet mechanism ensures complete crimp cycle
- Emergency only ratchet release
- Terminal/wire positioning aids & Ins. adjustment on most tools
- Ergonomic non-slip handles
- Approximate weight 0.59 kg (1.3 lbs)



Part Number	Description	mm ² (AWG) or other
1901611-1	PIDG STRATO-THERM Terminals & Splices	0.2 - 0.6 (24-20)
1901600-1	PIDG STRATO-THERM Terminals & Splices	1.0 - 1.5 (18-16)

CERTI-CRIMP II SAHT - Head Assy

Head only for use with Power Assist options

Image representative of type only

Features:

Heads can be removed from Hand Tools, or are also available as a [-3] option.

Example 91500-1 CERTI-CRIMP II SAHT; the head can be removed from the handles and used along with this adapter on the Electric Terminator . Alternatively 91500-3 (head only) is also available.

Use with:

BT 3500 Battery-Hydraulic Hand Tools:

2-2031400-1 + CCII Adapter 2031480-1 - EMEA

or

3-2031400-1 + CCII Adapter 2031480-1 - UK

1583527-1 Micro Pneumatic Adapter

1213860-1 Adapter Electric Terminator EU

see Power Assist section for more information

Double Action Hand Tool

Note: The approvals shown against the tools listed are only applicable when using terminals and wires recommended for the relevant industry.
Widely used in Aircraft and Military applications

Image representative of type only

Features:

- Fixed dies
- Ratchet mechanism ensures complete crimp cycle
- Emergency only ratchet release
- Terminal/wire positioning aids & Ins. adjustment on many tools
- Ergonomic non-slip handles
- Approximate weight 0.54 kg (1.2 lbs)



Part Number	Description	mm ² (AWG) or other
45216	PIDG Closed End Splice	1.0 - 1.5 (18-16)
47386	PIDG & PLASTI-GRIP Terminals; PIDG Splices Standard tool for GB Railways - Qualified; Mil-T-7928/7; LUL RSE 024 pt6 & EE6161 Marks the applied product with a one dot indent code.	0.4 - 1.5 (22-16)
47386-5	PIDG & PLASTI-GRIP Terminals; PIDG Splices French Special - Qualified; Mil-T-7928 - AMP specified level Marks the applied product with a one dot indent code. Includes French Instruction Sheet	0.4 - 1.5 (22-16)
47387	PIDG & PLASTI-GRIP Terminals; PIDG Splices Standard tool for GB Railways - Qualified; Mil-T-7928; LUL RSE 024 pt6 & EE6161 Marks the applied product with a two dot indent code.	1.25 - 2.0 (16-14) 0.6 - 1.5 (20-16) HD
47386-4	PIDG & PLASTI-GRIP Terminals; PIDG Splices & FASTON EMEA Special - Qualified; Mil-T-7928 - AMP specified level for Ringtongues only Marks the applied product with a one dot indent code.	0.4 - 1.5 (22-16)
47387-7	PIDG & PLASTI-GRIP Terminals; PIDG Splices & FASTON EMEA Special - Qualified; Mil-T-7928 - AMP specified level for Ring Tongues only Marks the applied product with a two dot indent code.	1.5 - 2.5 (16-14) 0.6 - 1.5 (20-16) HD
90035-3	PIDG FASTON - Special GB Railways Tool Qualified; LUL RSE 024 pt6 & EE6161	0.4 - 1.0 (22-18)
90009-8	PIDG FASTON - Special GB Railways Tool Qualified; LUL RSE 024 pt6 & EE6161	1.5 - 2.5 (16-14)
482930-1	Special French tool for PIDG FASTON 2.8 (.110) with crimp orientation at 90° Marks the applied product with a one dot indent code.	0.15 - 0.4 (26-22)
47907-1	PIDG Terminals & Splices	0.2 - 0.56 (24-20)
46121	PIDG Terminals & Splices; PLASTI-GRIP Butt Splices Marks the applied product with a one dot indent code	0.15 - 0.4 (26-22)
47304	PIDG Terminals & Splices; PLASTI-GRIP Butt Splices for thin wall insulation Marks the applied product with a one dot indent code	0.15 - 0.4 (26-22)
525690	Special GB Aerospace PIDG & PLASTI-GRIP Ring Tongue Tool. Equivalent to 47386 but has special retaining pins/rings to reduce the risk of tool parts falling off whilst building and maintaining aircraft.	0.6 - 1.0 (20-18)
525691	Special GB Aerospace PIDG & PLASTI-GRIP Ring Tongue Tool. Equivalent to 47387 but has special retaining pins/rings to reduce the risk of tool parts falling off whilst building and maintaining aircraft.	1.25 - 2.0 (16-14)
753786-1	POSITIVE LOCK 4.8 [.187] Mk II Receptacle	0.70 - 2.08 (20-14)
753815-1	POSITIVE LOCK 6.3 [.250] Mk II Tablock Flag Receptacle	2.0 - 3.37 [14-12]
69363	SOLISTRAND Terminals & Splices - Standard Tool. Qualified; Mil-T-7928; LUL RSE 024 pt6 & EE6161	0.15 - 0.6 (26-20)
49935	SOLISTRAND Terminals & Splices Qualified; Mil-T-7928; LUL RSE 024 pt6 & EE6161	0.4 - 6.0 (22-10)
525693	Special tool for SOLISTRAND Terminals & Splices (GB) Equivalent to 49935 but has special retaining pins/rings to reduce the risk of tool parts falling off whilst building and maintaining aircraft.	0.4 - 6.0 (22-10)
49592	SOLISTRAND Terminals & Splices Qualified; Mil-T-7928; LUL RSE 024 pt6 & EE6161	2.5 - 4.0 (14-12)
46447	SOLISTRAND STRATO-THERM High Temp & Heat Resistant Terminals & Splices	0.4 - 6.0 (22-10)
46673	STRATO-THERM Uninsulated Terminals & Splices	0.4 - 1.5 (22-16)
46673-1	STRATO-THERM Uninsulated Terminals & Splices [thin wall cable]	0.4 - 1.5 (22-16) [thin wall cable]

Adapter - Double Action Hand Tool to 626 Pneumatic

1213563-1 - Adapter only

Features:

Heads can be removed from Hand Tools, example: the Handles from 47386 can be removed and the head used with this Adapter (includes cam).

Also required:

Hand held power unit 189721-1

or

Foot actuated Power Unit 189722-1

for more information, please see the Power Assist section

Image representative of type only

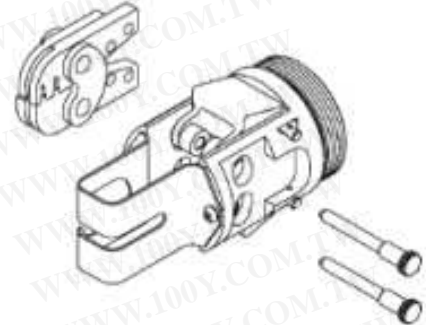

Head only - Double Action Hand Tool

For use in Power-assist options

Features:

Identical to the equivalent Hand Tool Head

Fixed dies

Terminal/wire positioning aids & Ins. adjustment on many Heads.

Use with:

BT 3500 Battery-Hydraulic Hand Tools:

2-2031400-1 + DAHT Adapter 2119483-1 - EMEA

or

3-2031400-1 + DAHT Adapter 2119483-1 - UK

Image representative of type only

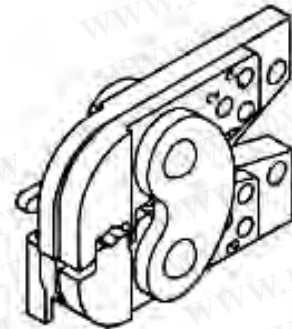

Part Number	Description	mm ² (AWG) or other
1-47386-0	PIDG & PLASTI-GRIP Terminals; PIDG Splices Head from 47386 - Qualified; Mil-T-7928/7; LUL RSE 024 pt6 & EE6161 Marks the applied product with a one dot indent code.	0.4 - 1.5 (22-16)
1-47387-0	PIDG & PLASTI-GRIP Terminals; PIDG Splices Head from 47387 - Qualified; Mil-T-7928; LUL RSE 024 pt6 & EE6161 Marks the applied product with a two dot indent code.	1.25 - 2.0 (16-14) 0.6 - 1.5 (20-16) HD Ins. Ø3.8mm1 max
1-47907-1	PIDG Terminals & Splices	0.2 - 0.56 (24-20)
1-46121-0	PIDG Terminals & Splices; PLASTI-GRIP Butt Splices Qualified; Mil-T-7928; LUL RSE 024 pt6 & EE6161 Marks the applied product with a one dot indent code	0.15 - 0.4 (26-22)
1-47304-0	PIDG Terminals & Splices; PLASTI-GRIP Butt Splices for thin wall insulation Marks the applied product with a one dot indent code	0.15 - 0.4 (26-22)

C-Head SAHT

69710-1 - Base Tool without Die-set

Widely used in Aircraft and Military applications

Can be used with all C-Head SAHT Dies

Image representative of type only

Features:

Interchangeable Dies

Straight action jaw closure

Ratchet mechanism ensures complete crimp cycle

Emergency only ratchet release

Approximate weight 0.86 kg (1.9 lbs)



C-Head SAHT - LD

1901260-1 Base Tool without Die-set

A light duty alternative to 69710-1

Can be used with all C-Head SAHT Dies EXCEPT:

- Die-set - C-Head SAHT - HD
- Through Splice applicators

Image representative of type only

Features:

Interchangeable Dies

Straight action jaw closure

Ratchet mechanism ensures complete crimp cycle

Emergency only ratchet release

Ergonomic non-slip handles

Approximate weight 0.5 kg (1.1 lbs)



Die-set - C-Head SAHT

A range of Die-sets for many premium crimp applications

Features:

Use in:

Hand Tool Frame 69710-1

Hand Tool Frame 1901260-1 (see restrictions)

Power Assist options:

BT 3500 Battery-Hydraulic Hand Tools:

2-2031400-1 + C-Head SAHT Adapter 2119810-1 - EMEA

or

3-2031400-1 + C-Head SAHT Adapter 2119810-1 - UK

1901556-1 Adapter Electric Terminator EU

1-528051-8 Adapter Bench Press AT-SC

For more information see the Power Assist section

Image representative of type only

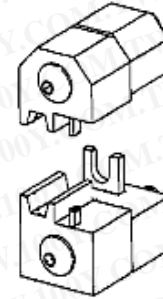

Part Number	Description	mm ² (AWG) or other
58212-1	AMPLIMITE	RG 142, 142A, 142B
576711	PIDG STRATO-THERM Terminals with PTFE or PEEK for thin-wall Insulation	0.2 - 0.4 (24-22)
576720	PIDG STRATO-THERM Terminals with PTFE or PEEK for thin-wall Insulation	0.5 (20)
576715	PIDG STRATO-THERM Terminals with PTFE or PEEK for thin-wall Insulation	1.0 (18)
576714	PIDG STRATO-THERM Terminals with PTFE or PEEK for thin-wall Insulation	1.5 (16)
47807-1	PIDG, PLASTI-GRIP Terminals & Splices	1.5 - 2.5 (16-14)
47806-2	PIDG, PLASTI-GRIP, Terminals & Splices	0.4 - 1.5 (22-16)
1-539634-9	Pin / Socket size 8	Gore Cable Type: GSC-03-81748-00

Die-set - C-Head SAHT - HD

A range of Heavy Duty Die-sets for many premium crimp applications

Features:

Use in:

Hand Tool Frame 69710-1

Power Assist options:

1901556-1 Adapter Electric Terminator EU

1-528051-8 Adapter Bench Press AT-SC

For more information see the Power Assist section

Image representative of type only

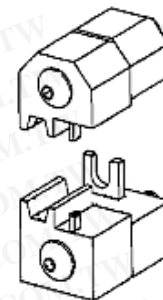

Part Number	Description	mm ² (AWG) or other
59993-1	AMPLIMITE	8 (10)
69735	PIDG STRATO-THERM Terminals & Splices with PTFE Insulation	4.0 - 6.0 (12-10)
576716	PIDG STRATO-THERM Terminals with PTFE or PEEK for thin-wall Insulation	2.5 (14)
576742	PIDG STRATO-THERM Terminals with PTFE or PEEK for thin-wall Insulation	4.0 (12)
576723	PIDG STRATO-THERM Terminals with PTFE or PEEK for thin-wall Insulation	6.0 (10)
47808-6	PIDG, PLASTI-GRIP Terminals & Splices	4.0 - 6.0 (12-10)
90145-1	TYPE XII Contact	2.5 - 4.0 (14-12)
90140-1	TYPE XII Contact	6.0 - 10.0 (10-8)
58380-1	Universal MATE-N-LOK	3.0 (12)
58380-2	Universal MATE-N-LOK	5.0 (10)

Heavy Head Hand Tool

Note: The specifications shown against the tools listed are only applicable when using terminals recommended for the relevant industry
 Widely used in Aircraft and Military applications

Image representative of type only

Features:

- Fixed dies
- Straight action jaw closure
- Ratchet mechanism ensures complete crimp cycle
- Emergency only ratchet release
- Terminal/wire positioning aids & Ins. adjustment on most tools
- Approximate weight 0.95 kg (2.1 lbs)



Part Number	Description	mm ² (AWG) or other
234170-1	AMP DYNAMIC D-5	1.5 - 2.5 (16-14)
234171-1	AMP DYNAMIC D-5	4.0 - 6.0 (12-10)
1366044-1	AMP DYNAMIC D-5 Receptacle	8.0 (10)
90246-1	PIDG FASTON - Standard tool	2.5 - 4.0 (14-12)
90276-2	PIDG FASTON Qualified; LUL RSE 024 pt6 & EE6161	4.0 - 6.0 (12-10) 1.5 - 2.5 (16-14) HD
484364-1	PIDG STRATO-THERM Terminals & Splices	1.0 (18)
576782	Special GB Aerospace tool for PIDG STRATO-THERM Terminals with PTFE or PEEK for thin-wall Insulation Qualified to BS 4G178	2.5 (14)
576783	Special GB Aerospace tool for PIDG STRATO-THERM Terminals with PTFE or PEEK for thin-wall Insulation Qualified to BS 4G178	4.0 (12)
576784	Special GB Aerospace tool for PIDG STRATO-THERM Terminals with PTFE or PEEK for thin-wall Insulation Qualified to BS 4G178	6.0 (10)
576778	Special GB Aerospace tool for PIDG STRATO-THERM Terminals with PTFE or PEEK for thin-wall Insulation Qualified to BS 4G178	0.2 - 0.4 (24-22)
576779	Special GB Aerospace tool for PIDG STRATO-THERM Terminals with PTFE or PEEK for thin-wall Insulation Qualified to BS 4G178	0.6 (20)
576780	Special GB Aerospace tool for PIDG STRATO-THERM Terminals with PTFE or PEEK for thin-wall Insulation Qualified to BS 4G178	1.0 (18)
576781	Special GB Aerospace tool for PIDG STRATO-THERM Terminals with PTFE or PEEK for thin-wall Insulation Qualified to BS 4G178	1.5 (16)
59239-4	PIDG, PLASTI-GRIP Terminals & Splices - Standard tool for GB Railways Qualified; Mil-T-7928; LUL RSE 024 pt6 & EE6161 Marks the applied product with a one dot indent code.	3.0 - 5.0 (12-10) 1.5 - 2.5 (16-14) HD
59287-2	PIDG, PLASTI-GRIP Large Expansion Terminals & Splices	4.0 - 6.0 (12-10) (16-14) HD
525692	Special GB Aerospace Tool. Equivalent to 59239-4 but has special retaining pins/rings to reduce the risk of tool parts falling off whilst building and maintaining aircraft.	4.0 - 6.0 (12-10)
69355	SOLISTRAND Terminals & Splices	10.0 (8)
59461	STRATO-THERM Uninsulated Terminals & Splices with Insulation Support	4.0 - 6.0 (12-10) (16-14) HD
90382-2	TYPE XII Contact	1.5 - 4.0 (16-12)
90384-1	TYPE XII Contact	6.0 - 10.0 (10-8)

Heavy Head Hand Tool - Head Assy

Head only for use with Power Assist options

Features:

Heads can be removed from Hand Tools and used with these Power Assist options:

BT 3500 Battery-Hydraulic Hand Tools:
2-2031400-1 + HHHH Adapter 2119840-1 - EMEA
or
3-2031400-1 + HHHH Adapter 2119840-1 - UK

Image representative of type only

Adapter - Heavy Head to 626 Pneumatic

525432-1 - Adapter only

Features:

Heads can be removed from Hand Tools, example:
the Handles from 59239-4 can be removed and the head used
with this Adapter on the 626 Pneumatic system.

Also required:

Adapter Holder with Ratchet 356304-1
or Adapter Holder without Ratchet 189928-1
and
Hand held power unit 189721-1
or Foot actuated Power Unit 189722-1

see Power Assist section for more information

Image representative of type only

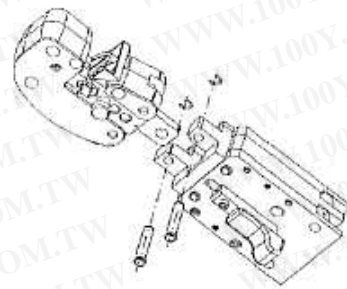

Reel-Fed CERTI-LOK

A unique tool that applies terminals from special small reels

Features:

- Terminal feeding and cutting device
- Straight action jaw closure
- Ratchet mechanism ensures complete crimp cycle
- Easy access ratchet release
- Handle pressure adjustment with locking device
- Ergonomic non-slip handles

Image representative of type only



Part Number	Description	mm ² (AWG) or other
539608-1	AMP MOD II	0.02 - 0.20 (32-24)
734203-1	AMP MOD IV	0.12 - 0.14 (26)
734204-1	AMP MOD IV	0.2 - 0.56 (24-20)
734643-1	AMPLIVAR	
734870-2	MICRO MATCH COSI contact	0.08 - 0.2 (28-24)
734870-1	MICRO MATCH COSI contact	0.2 - 0.6 (24-20)
734216-1	TYPE III+	0.2 - 1.5 (24-16)

CERTI-LOK

169400 - Base Tool without Die-set

Features:

- Interchangeable Dies
- Straight action jaw closure
- Ratchet mechanism ensures complete crimp cycle
- Easy access ratchet release
- Handle pressure adjustment with locking device
- Ergonomic non-slip handles
- Approximate weight 0.64 kg (1.4 lbs)

Image representative of type only



Adapter - CERTI-LOK to Electric Terminator

169411 - Adapter only

Features:

Adapts the Electric Terminator 539630-1 to take CERTI-LOK Dies

for more information on the Press and Press options, please see the Power Assist section

Image representative of type only



PEZ 100

539717-1 - Base Tool without Die-set
 1579000-1 - Base Tool without Die-set Long Handles

Image representative of type only

Features:

- Interchangeable Dies
- Flap type terminal locator
- Straight action jaw closure
- Ratchet mechanism ensures complete crimp cycle
- Easy access ratchet release
- Handle pressure adjustment with locking device
- Ergonomic non-slip handles



ERGOCRIMP

539635-1 - Base tool without Die-set
 Note: This tool is not compatible with SDE Dies

Image representative of type only

Features:

- Interchangeable Dies
- Virtually a straight action jaw closure
- Ratchet mechanism ensures complete crimp cycle
- Easy access ratchet release
- Handle pressure adjustment with locking device
- Ergonomic non-slip handles
- Approximate weight 0.59 kg (1.3 lbs)



Spare parts Kit 539635-2 (excluding main spring)
 Main Spring PN 1579005-1

Tetra-Crimp Hand Tool

58078-3 - Base Tool without Die-set

Image representative of type only

Features:

- Interchangeable Dies
- Ratchet mechanism ensures complete crimp cycle
- Tamper proof ratchet release setting
- Emergency ratchet release feature
- Terminal locator / support and wire stop on many tools
- Approximate weight 0.64 kg (1.4 lbs)
- Ergonomic non-slip handles



Part Number	Description	mm ² (AWG) or other
58052-3	Die-set for ULTRA FAST	0.15 - 0.4 (26-22)
90390-3	Die-set for ULTRA FAST (including Flag Terminals)	0.4 - 1.0 (22-18)
90391-3	Die-set for ULTRA FAST (including Flag Terminals)	1.5 - 2.5 (16-14)
58079-3	Die-set for ULTRA FAST PLUS	0.4 - 1.0 (22-18)
58080-3	Die-set for ULTRA FAST PLUS	1.5 - 2.5 (16-14)

Mini CERTI-LOK

A light weight and compact tool for many commercial applications

Features:

- Fixed dies
- Straight action jaw closure
- Ratchet mechanism ensures complete crimp cycle
- Easy access ratchet release
- Handle pressure adjustment with locking device
- Easy terminal positioning with 'Flap Locator' (some tools)
- Ergonomic non-slip handles
- Approximate weight 0.46 kg (1.0 lbs)

Image representative of type only



Modular Mini CERTI-LOK

Based on the Mini Certi-Lok tool

Features:

Heads with identical features to the Mini Certilok tool

- Choice of two handle lengths:
- 2-1579005-1 Short Handle
- 2-1579005-2 long Handle

Interchangerbility via snap-in pins.

Image representative of type only



C-Frame Hand Tool

6-1419172-9 - Base Tool without Die-set

Features:

- Interchangeable Dies
- Double action jaw closure
- Ratchet mechanism ensures complete crimp cycle
- Easy access ratchet release
- Handle pressure adjustment with locking device
- Ergonomic non-slip handles
- Approximate weight 0.55 kg (1.2 lbs)

Image representative of type only



Part Number	Description	mm ² (AWG) or other
1583684-1	Die-set for ADK Series Back Shell	6.0 mm Cable Dia Max
1583684-2	Die-set for ADK Series Back Shell	7.5 mm Cable Dia Max
1583684-3	Die-set for ADK Series Back Shell	8.5 mm Cable Dia Max
1583684-4	Die-set for ADK Series Back Shell	9.5 mm Cable Dia Max
948761-1	Complete tool for HDE20 Ferrule	Cable Ø4.8 - 6.3
948761-2	Complete tool for HDE 20 Ferrule	Cable Ø6.3 - 8.2
948761-3	Complete tool for HDE20 Ferrule	Cable Ø8.2 - 11.1
734566-1	Complete tool for N Series 50 & 70 ohm	

D-Frame Tool

Features:

- Fixed Die-sets
- Small and lightweight
- Ratchet mechanism ensures complete crimp cycle
- Easy access ratchet release
- Handle pressure adjustment with locking device
- Ergonomic non-slip handles
- Approximate weight 0.55 kg (1.2 lbs)

Image representative of type only



Part Number	Description	mm ² (AWG) or other
947488-1	Coax - BNC, TNC	Cable Dia 5 & 6mm
947679-1	HE 13 / 14 Crimp-on Snap-in	0.08 - 0.2 (28-24)
2-1579002-0	Wire Wire End Ferrules (Square crimp form)	0.5 - 6.0 (20-10)

Trapezium Crimp Tool

Special Trapezium crimp tool for Wire End Ferrule applications

Features:

- Ratchet mechanism ensures complete crimp cycle
- Easy access ratchet release
- Handle pressure adjustment with locking device
- Ergonomic non-slip handles

Image representative of type only



Part Number	Description	mm ² (AWG) or other
734641-2	Wire End Ferrules (trapezium crimp form)	0.14 - 6.0 (26-10)
734641-3	Wire End Ferrules (trapezium crimp form)	0.5 - 10 (20-6)
734641-4	Wire End Ferrules (trapezium crimp form)	10.0 - 16.0 (8-6)

Square Crimp Tool

Special Square crimp tool for Wire End Ferrule applications

Features:

- Ratchet mechanism ensures complete crimp cycle
- Easy access ratchet release
- Handle pressure adjustment with locking device
- Ergonomic non-slip handles

Image representative of type only



Part Number	Description	mm ² (AWG) or other
539660-1	Wire Wire End Ferrules (square crimp form)	0.08 - 10.0 (28-7)
539661-1	Wire Wire End Ferrules (square crimp form)	0.75 - 10 (20-8)
7-1579014-0	Wire End Ferrules DIN 46228 Pt. 1 & 4 - crimp length 13mm. Crimp is indented on two sides only - (better for smaller sizes)	0.08 - 10.0 (28-7)

Service Tool

734790-1 - Base Tool without Die-set

Features:

- Interchangeable Dies
- Ratchet mechanism ensures complete crimp cycle
- Easy access ratchet release
- Handle pressure adjustment with locking device
- Ergonomic non-slip handles
- Approximate weight 0.59 kg (1.3 lbs)

Image representative of type only



TERMI-POINT Service Tool

Features:

For the repair of crimped connections

Image representative of type only



Part Number	Description	mm ² (AWG) or other
654632-1	Service Tool without Mandrel for Maxi TERMI-POINT	
654633-1	Twin Mandrel (Yellow / Red) for 654632-1	[24-20]
655136-3	Service Tool without Mandrel - Standard TERMI-POINT	0.2 - 0.4 (24-22)

TERMI-POINT Hand Tool

Features:

- Pneumatic options (pictured)
- Interchangeable Mandrels
- Terminals fed from Reel

Image representative of type only



Part Number	Description	mm ² (AWG) or other
871295-5	Mandrel (brown) for Maxi TERMI-POINT Tool 871087-2	0.15 (26) Ins. Ø0.76-1.40mm
871295-2	Mandrel (red) for Maxi TERMI-POINT tool 871087-1	0.2 (24) Ins. Ø0.86-1.65mm
871295-4	Mandrel (red) for Maxi TERMI-POINT Tool 871087-2	0.2 (24) Ins. Ø0.86-1.65mm
69561-4	Mandrel (red) for Maxi TERMI-POINT tool 654182-1	0.2 (24) Ins. Ø1.1 -1.65mm
871295-3	Mandrel (orange) for Maxi TERMI-POINT Tool 871087-2	0.4 (22) Ins. Ø0.91-1.65mm
871295-1	Mandrel (yellow) for Maxi TERMI-POINT tool 871087-1	0.56 (20) Ins. Ø0.91-1.65mm
69561	Mandrel (yellow) for Maxi TERMI-POINT tool 654182-1	0.56 (20) Ins. Ø1.17-1.65mm
69561-1	Mandrel (yellow) for for Maxi TERMI-POINT tool 654182-1	0.56 (20) Ins. Ø1.68-2.16mm
654182-1	Hand Tool without Mandrel - Maxi TERMI-POINT	0.6 - 0.2 (20-24)
871087-1	Hand Tool (pneumatic) without Mandrel - Maxi TERMI-POINT	0.6 - 0.2 (20-24)
69526-2	Hand Tool without Mandrel - Standard TERMI-POINT	0.08 - 0.4 (28-22)
69551-5	Mandrel (black) for Standard TERMI-POINT Tool 69526-2	0.08 (28) Ins. Ø1.14-1.65mm
69551-6	Mandrel (brown) for Standard TERMI-POINT Tool 69526-2	0.15 (26) Ins. Ø0.56-1.14 mm
1-69411-9	Mandrel (brown) for Standard TERMI-POINT Tool 69526-2	0.15 (26) Ins. Ø1.14-1.65mm
69551-9	Mandrel (red) for Standard TERMI-POINT Tool 69526-2	0.2 (24) Ins. Ø0.74-1.23mm
1-69411-3	Mandrel (red) for Standard TERMI-POINT Tool 69526-2	0.2 (24) Ins. Ø1.10-1.65mm
871087-2	Hand Tool (pneumatic) without Mandrel - Standard TERMI-POINT	0.4 - 0.15 (22-26)
69551-8	Mandrel (orange) for Standard TERMI-POINT Tool 69526-2	0.4 (22) Ins. Ø0.87-1.23mm
1-69411-4	Mandrel (orange) for Standard TERMI-POINT Tool 69526-2	0.4 (22) Ins. Ø1.14-1.65mm

Service Kit Tool

Ideal for Service and Repair

Features:

- Tool-less Die change
- Ratchet mechanism ensures complete crimp cycle
- Emergency ratchet release feature
- Ergonomic non-slip handles
- Approximate weight 0.46 kg (1.0 lbs)

Image representative of type only



Part Number	Description	mm ² (AWG) or other
3-1579000-0	Hand Tool Frame only - Service Kit Tool	

Die-set - Service Kit Tool

Build up your own kit!

Features:

- Upper & lower Dies are permanently joined
- Interlocking Die-set holders

Use in Service Kit Tool 3-1579000-0

Image representative of type only



Part Number	Description	mm ² (AWG) or other
3-1579016-4	FASTON 6.3 [.250]	0.5 - 6.0 (20-10)
3-1579016-1	PIDG, PLASTIGRIP Terminals & Splices	0.1 - 6.0 (26-10) Green / Yellow
3-1579016-2	PIDG, PLASTIGRIP Terminals & Splices	0.5 - 2.5 (20-14) Red / Blue
3-1579016-3	SOLISTRAND Terminals & Splices	0.5 - 6.0 (20-10)
3-1579016-5	Wire End Ferrules	0.25 - 10.0 (24-8)

Pistol Grip

Specially Developed to cover a wide range of IDC products - these tools are ideal for small batch production and repair

Image representative of type only

Features:

- Interchangeable Heads
- Complete cycle ratchet control
- Product automatically indexes after insertion
- Head rotates for user convenience



Part Number	Description	mm ² (AWG) or other
548053-1	AMP CT 2.0 Receptacle	2 to 28 ways
870086-2	AMP MOD MT Female Connector, Dual Row	0.15 - 0.4 (26-22)
870086-3	AMP MOD MT Female Polarised Connectors, Dual Row	0.15 - 0.4 (26-22)
1372039-1	AMP MONO-SHAPE MK II Tab connector	0.35 - 1.5 (24-16)
528015-7	AMP MONO-SHAPE Tab connector	0.5 - 1.5 (20-16)
539453-1	AMP multifitting MK II	0.35 - 1.0 (24-18)
870088-3	AMPLIMITE HDE-20	0.05 - 0.6 (30-20)
946807-1	HE-13/14 (180°)	0.08 - 0.22 (28-24)
945419-1	HE-13/14 (90°)	0.08 - 0.22 (28-24)
656154-2	MiniMaTch	
549012-1	Modu w. pin housing 964144	1x4 way
539638-1	Modu w. pin housing 964144	1x5 way
734173-1	MT 6	0.4 - 1.0 (22-18)
656154-1	MT Connector - Decrete wire	2 to 20 Posns
734175-1	MT-6-M / Sonderversion	2 to 12 Posns
656154-5	MT-EDGE 5.0	0.5 (20)
658096-3	RV-100 MULTIPLEXER 16 Posn. RV-100 32, 48, 64, 80, 96 Posn.; RV-100-4 32 Posn.	0.05 - 0.35 (30-22)
873710-1	TANDEM-SPRING	2x13 way
549013-1	TS Receptacle	1x4 way

Pistol Grip II

58074-1 - Manual Handle without Head
 58075-1 - Pnuematic Handle without Head
 Ideal for small batch production and repair

Image representative of type only

Features:

- Interchangeable Heads
- Complete cycle ratchect control
- Product automatically indexes after insertion
- Head rotates for user convenience



Part Number	Description	mm ² (AWG) or other
58372-1	Head only for AMP CT 2.0	2 to 28 ways
58569-1	Head only for AMP MOD MTE Receptacle Inserts crimped Contacts into Housing	
58336-1	Head only for AMP MOD MTE Receptacle	0.03 - 0.4 (30-22)
58063-2	Head only, for AMPLIMITE HDE-20	0.05 - 0.6 (30-20)
608868-1	Complete Tool, for AMPLIMITE HDE - 20	0.05 - 0.6 (30-20)
937317-1	Complete Tool, for Mini CT MT	2 to 20 Posns
58246-2	Head only for MTA 100	0.06 - 0.4 (30-22)
58579-1	Complete Tool, for MTA 100	0.08 - 0.4 (28-22)
58246-1	Head only, for MTA 100	0.09 - 0.4 (28-22)
58247-1	Head only, for MTA 156 & descrete wires	0.15 - 1.0 (26-18)
58247-3	Head only, for MTA 156 Descrete Wire, Jacketed or Ribbon Cable applications	0.15 - 1.0 (26-18)
58580-1	Complete Tool, for MTA 156	0.15 - 1.0 (26-18)
58443-1	Head only for MTA-156 Discrete Wire Receptacles	[26-18] Ins. Ø2.41mm max

Pistol Grip III

1-528015-6 - Base Tool without Head
 Order Handle and Head separately
 Ideal for small batch production and repair

Image representative of type only

Features:

- Interchangeable Heads
- Complete cycle ratchect control
- Product automatically indexes after insertion



Part Number	Description	mm ² (AWG) or other
785900-1	Complete Tool for AMP MONOSHAPE	
734042-1	Head only for HE-13/14 (180°)	0.08 - 0.22 (28-24)
734043-1	Complete Tool for HE 13/14 (180°)	0.08 - 0.22 (28-24)
734040-1	Head only for HE-13/14 (90°)	0.08 - 0.22 (28-24)
734041-1	Complete Tool for HE-13/14 (90°)	0.08 - 0.22 (28-24)
870090-1	Complete Tool for MT Connector, Ribbon cable	2 to 20 Posns

Special Hand Tool for DUOPLUG 2.5

549033-1 - complete tool

Features:

Suitable for low volume production and repair work.
 The connector housing is placed in a support frame and the handles are partially closed, then the wire can be inserted up against the wire stop.
 Completely closing the handles pushes the wires into the IDC contacts and completes the termination.

Image representative of type only



Hand Tool - ANSLEY 779-2100

1437000-6 for all STD DIP Plugs

Features:

One Stationary Handle
 One Moveable Handle
 Upper Platten
 Lower Platten mounting Plate
 Accepts a range of Lower Platten Blocks to crimp a wide variety of products

Image representative of type only

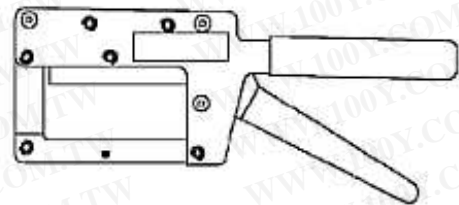

Part Number	Description	mm ² (AWG) or other
1-1437000-2	Platten Block - ANSLEY 609 / 622 Ribbon Cable Socket Connectors	10 to 60 Pos
1437000-8	Platten Block - ANSLEY 609 Ribbon Cable Socket Connectors	10 to 64 Pos
1-1437000-3	Platten Block - ANSLEY 622 Ribbon Cable Socket Connectors	10 to 60 Pos
1437000-9	Platten Block - ANSLEY 622 Ribbon Cable Socket Connectors	10 to 64 Pos

Standard Extraction Tool

Insert discrete terminals into connector housings or remove them, without causing damage to either the terminals or housings.

Image representative of type only

Features:

This standard tool design features a comfortable handle and snap-in/out protective cover. Users can stow the business end of the tool when not in use, to protect against inadvertent damage to product or personal injury.



Part Number	Description	mm ² (AWG) or other
1-1579007-1	AMP MCP 1.5k; AMP MCP 1.5k (SWS)	
1579007-1	AMP MCP 2.8	
1-1579007-3	AMP MCP 6.3/4.8k Receptacle	
1-1579007-7	AMP MCP 9.5 Tab; Maxi Power TIMER Receptacle	
1-1579008-6	AMP-DUAC Connectors	
1579007-9	AMPLIMITE HD-20	
1-1579007-5	ECONOSEAL III LC 1.8 [.070]	
3-1579007-6	GET .064 Pin/Socket	
1579008-5	IEC-Terminal	
4-1579007-1	Locking Tab 3.3 Receptacle	
539764-1	MATE-N-LOK 3.5 (.140)	
1-1579007-0	MCON 1.2-CB Receptacle; MCON 1.2-CB Receptacle (SWS) - Secondary Lock	
1579007-8	MCON 1.2-CB; MCON 1.2-CB (SWS)	
5-1579007-3	MCON 1.2-LL; MCON 1.2-LL (SWS)	
5-1579008-2	MCON 2.8 Receptacle; MCON 2.8 Receptacle (SWS)	
6-1579007-3	Micro Power Quadlok	
5-1579007-5	Micro TIMER I	
539960-1	Micro TIMER II, III, IV; TAB 1.6	
4-1579007-8	MQS	
6-1579007-0	MQS Clean Body	
3-1579007-7	Pin Ø1.5 (Spare tube 3-1579007-8)	
1-1579007-8	Pin/Socket Ø2.5 (Spare tube 4-1579007-7)	
539967-1	Pin/Socket Ø4.0 (Spare tube 5-1579007-2)	
6-1579007-4	Power Quadlok	
1579007-2	RAIL Contact	
7-1579007-0	SENSOR-TAB 1.5; SENSOR-REC 1.5 Type II	
2-1579007-5	Standard & Junior Power TIMER (asymmetric Tab contacts)	
1-1579007-6	Standard & Junior Power TIMER Receptacle and (symmetric Tab contacts)	
1-1579007-4	Standard & Junior TIMER; FASTIN-FASTON & POSITIVE-LOK Tab 2.8, 4.8, 5.8, 6.3	
4-1579007-3	Standard TIMER etc. Kit comprises; 1-1579007-4 & 1-1579007-6	
9-1579007-1	SUPER-SEAL 1.5; MULTILOCK 070	
9-1579007-5	Universal MATE-N-LOK Contacts - only with Housing contact cavity Ø 3.55mm	
9-1579007-6	Universal MATE-N-LOK Socket 926884 / 926885 with Housing contact cavity Ø5.0	
539972-1	Universal MATE-N-LOK; Socket Ø1.5; TYPE II, III+; CI-2, -3, -H; Econoseal E Series (Spare tube 5-1579007-0)	

Extraction Tool

Insert discrete terminals into connector housings or remove them, without causing damage to either the terminals or housings.

Image representative of type only

Features:

Many different design types currently exist for our vast terminal range, which we continue to convert. If you would like the tool you use converted to our Standard design, want a custom kit or tools in this design for other manufacturers products please contact us, and where volumes permit we will be pleased to provide you with a quotation for your requirement.



Part Number	Description	mm ² (AWG) or other
455822-1	AMP COMBO LINE	
723986-1	AMP DRAWER	
234168-1	AMP DYNAMIC D-3	
409158-1	AMP DYNAMIC D-5	
465195-1	AMP-LEAF	
843473-1	AMP MOD I, IV, V; TANDEM SPRING	
166645-1	AMP MOD IV, V	
843477-1	AMP MOD MTE; SHORT-POINT	
913923-1	AMP UNIVERSAL Power Connector	
188688-1	AMP DUAC	
91285-1	AMPLIMITE HD-20	
726364-2	AMPLIMITE HD-22	
318813-1	AMPLIMITE size 8; POWERBAND .125	
318837-1	COMM 093	
465644-1	Commercial MATE-N-LOK	
1276716-1	DYNAMIC D2	
724712-1	ECONOSEAL III HC 6.3 [.250] Receptacle	
1102855-1	HTS HDM Contacts	
1102855-7	HTS HE/HA Contacts	
1102855-2	HTS HND Contacts	
1102855-8	HTS HSK Contacts	
1102855-4	HTS HSM Contacts	
1102855-5	HTS HSS Contacts	
1102855-3	HTS HVT Contacts	
91084-1	LOCKING CLIP	
753787-1	MIC MK-2 Receptacle B TYPE	
724763-1	MIC Mk-I Tab	
723735-1	MIC Mk-I&II	
843996-6	MICRO MATE-N-LOK	
189727-1	Mini-Universal MATE-N-LOK	
455822-2	MR Contacts	
1276565-1	MULTILOCK 025	
755430-1	MULTILOCK 040	
715131-1	MULTILOCK 040 MkII	
755430-2	MULTILOCK 070	
342578-1	PM IV Cable seal- disassembly tool	
342576-1	PM IV Socket Ø3.0 mm	
724659-1	POSITIVE LOCK 4.8 [.187] Mk II Receptacle	
724659-2	POSITIVE LOCK 6.3 [.250] Mk II Receptacle	
724659-5	POSITIVE LOCK Mk II	
785084-1	SUPER-SEAL 1.5 (secondary lock of TAB Connector)	
69357-3	TERMI-POINT	0.08 - 0.6 (28-20)
91073-1	TWIN-LEAF	
305183-8	TYPE I; Miniature COAXICON	
726423	TYPE XII	

Standard Insertion Tool

Insert discrete terminals into connector housings or remove them, without causing damage to either the terminals or housings.

Image representative of type only

Features:

This standard tool design features a comfortable handle and snap-in/out protective cover. Users can stow the business end of the tool when not in use, to protect against inadvertent damage or personal injury.



Part Number	Description	mm ² (AWG) or other
1579008-9	AMP MCP 1.5 & 2.8 and Housings; 284848 & 284844	
3-1579007-2	Pin Ø2.5 (SWS) and Housing 1-967402-1	
1-1579007-9	Pin/Socket Ø4.0 (spare tube 5-1579007-1)	
5-1579018-6	Tab 1.6 (SWS)	

Insertion Tool

Insert discrete terminals into connector housings or remove them, without causing damage to either the terminals or housings.

Image representative of type only

Features:

Many different design types currently exist for our vast terminal range, which we continue to convert. If you would like the tool you use converted to our Standard design, want a custom kit or tools in this design for other manufacturers products – contact us, and where volumes permit we will be pleased to provide you with a quotation for your requirement.



Part Number	Description	mm ² (AWG) or other
380306-3	AMP 53 Series TAPER PIN	
552714-3	AMP Barrel Terminals	0.08 - 0.2 (28-24)
552714-4	AMP Barrel Terminals	0.08 - 0.4 (28-22)
552714-1	AMP Barrel Terminals	0.4 - 1.0 (22-18)
58430-1	AMPLIMITE .050 Shielded Connectors	
726363-2	AMPLIMITE HD-22	
344525-1	ECONOSEAL III, High Current with Seal	0.5 - 3.0 (20-14)
465665-1	FASTIN-FASTON 6.3 [.250] - requires Universal Handle 465629-1	
1102855-6	HTS Contacts	
274250-2	MAG-MATE	
59839-1	MTA-156	
965702-1	Pin/Socket Ø1.5 & Ø2.5 (Insulation less than Ø2.1mm)	Insulation less than Ø2.1mm
965700-1	Pin/Socket Ø4.0	
342577-1	PM IV Cable seal - assembly tool	
658167-1	RV-100	
725830-1	Standard TERMI-POINT	
658033-1	TYPE F	
200893-2	TYPE II, III+	
826790-3	TYPE III+, CI-2 Socket - Cable Seal protection tool	
826791-1	TYPE III+, CI-2 Pin - Seal protection tool	
455830-1	Universal MATE-N-LOK; Mini Universal MATE-N-LOK	
1583255-1	Z-Pack HM-Zd Vertical Pin Header	

Tee Handled Insertion Tool

Features:

- Comfortable moulded handle
- Moulded-in metal insert for long life

Image representative of type only



Part Number	Description	mm ² (AWG) or other
229384-1	AMP CHAMP Connectors	
91287-1	AMPLIMITE HDE-20	
525421-5	HE-13; HE-14	0.08 - 0.22 (28-24)
1-525421-3	IDC Bulb Holder 5 mm	0.2 (24)
525421-6	IDC FASTON	0.2 - 0.4 (24-22)
59803-1	MTA 100	0.08 - 0.4 (28-22)
59804-1	MTA 156	0.15 - 1.0 (26-18)

Insertion / Extraction Tool Kit

Custom kits made to suit your specific requirements

Insert discrete terminals into connector housings or remove them, without causing damage to either the terminals or housings

Image representative of type only

Features:

Kits are supplied in a rugged plastic carry case

This standard tool design features a comfortable handle and snap-in/out protective cover. Users can stow the business end of the tool when not in use, to protect against inadvertent damage or personal injury.



Part Number	Description	mm ² (AWG) or other
4-1579010-0	Insertion / Extraction Tool Kit - Renault	

ROTA-CRIMP Hand Tool

Generally used in Battery Lead applications

Features:

- Very large wire range covered
- Simply rotate the appropriate crimp nest into position
- Available with and without full cycle ratchet mechanism

Image representative of type only



Part Number	Description	mm ² (AWG) or other
600850	Tool without Ratchet for Battery Terminals & Lugs	10.0 - 120.0 (8-4/0)
600850-1	Tool with ratchet for Battery Terminals & Lugs (pictured)	10.0 - 120.0 (8-4/0)
601129-2	Tool with Ratchet for PLASTI-GRIP & Pre-insulated AMPPOWER Terminals; TERMINYL Terminals & Splices	Single Crimp 10.0 - 35.0 (8-2) Dual Crimp 1/0

Bantam ROTA-CRIMP Hand Tool

Generally used in Battery Lead applications

Features:

- Large wire range covered
- Simply rotate the appropriate crimp nest into position
- Ratchet mechanism ensures complete crimp cycle
- Easy access ratchet release

Image representative of type only



Part Number	Description	mm ² (AWG) or other
601075	Tool without Ratchet for Battery Terminals & Lugs	10.0 - 50.0 (8-1/0)
601075-1	Tool with Ratchet for Battery Terminals & Lugs (pictured)	10.0 - 50.0 (8-1/0)

Hydraulic Hand Tool - SOLISTRAND

Generally used in Military & Aerospace applications

Features:

- Integral Dies, simply rotate the appropriate die into position
- Pump action die closure

Image representative of type only



Part Number	Description	mm ² (AWG) or other
59975-1	SOLISTRAND Terminals & Splices	10.0 - 35.0 (8-2)

Hydraulic Head - SOLISTRAND

A version of 59975-1 for use with powered options

Features:

Integral Dies, simply rotate the appropriate die into position

Use with:

Optional Hose Assemblies; 1583662-1, 1583662-2 or 1583662-3

Respectively; 1.83 M (6'), 3 M (10'), 6.1 M (20')

Hand Pump 1583661-1

Foot Pump 1583659-1

Electric-Hydraulic Pumps; 439798-2, 523199-1

Image representative of type only



Part Number	Description	mm ² (AWG) or other
1673672-1	Complete Head for SOLISTRAND Terminals & Splices	10.0 - 35.0 (8-2)

Cable Cutter - Battery-Hydraulic Tool 100 KN

Take the effort out of cable cutting!

Features:

use with

1-579002-9 Battery-Hydraulic Tool 100 KN

Image representative of type only



Part Number	Description	mm ² (AWG) or other
4-1579002-5	Cutter Head only	Al & Cu up to Ø46mm (300 mm ² approx)

'U' Die Assy

A range of Die-sets for Heavy Duty crimping

Features:

Die outline dimensions conform to 'U' Die Industry Standard

Use in:

1490748-1 'U' Die 12 Ton Hydraulic Hand Tool

1490749-1 'U' Die 14 Ton Hydraulic Hand Tool

or

1213875-2 Battery-Hydraulic Tool Kit - 12 Ton 'U' Die

or

1490745-1 'U' Die 12 Ton Hydraulic Head

1490747-1 'U' Die 12 Ton Hydraulic Head (Titanium)

1490746-1 'U' Die 12 Ton Hydraulic Head - 1.5
(Excluding Die 1583097-1)

or

any 12 ton (min) compatible proprietary equipment

Image representative of type only

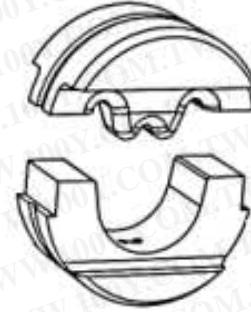

Part Number	Description	mm ² (AWG) or other
1583092-1	AMPOWER Terminals & Splices - Complete Die-set	16.0 (6)
1583093-1	AMPOWER Terminals & Splices - Complete Die-set	25.0 (4)
1583094-1	AMPOWER Terminals & Splices - Complete Die-set	35.0 (2)
1583095-1	AMPOWER Terminals & Splices - Complete Die-set	50.0 (1/0)
1583096-1	AMPOWER Terminals & Splices - Complete Die-set	70.0 (2/0)
1583097-1	AMPOWER Terminals & Splices - Complete Die-set	95.0 (3/0)
1490597-1	TERMINYL Terminals & Splices - Complete Die-set (PLASTI-GRIP where no insulation crimp is required)	10.0 (8)
1490598-1	TERMINYL Terminals & Splices - Complete Die-set (PLASTI-GRIP where no insulation crimp is required)	16.0 (6)
1490599-1	TERMINYL Terminals & Splices - Complete Die-set (PLASTI-GRIP where no insulation crimp is required)	25.0 (4)

'U' Die Assy (14 ton)

A range of Die-sets for Heavy Duty crimping

Features:

Die outline dimensions conform to 'U' Die Industry Standard

Use in:

1490749-1 'U' Die 14 Ton Hydraulic Hand Tool

or

1901821-1 'U' Die 12 Ton Hydraulic Head - 1.5

(Excluding Dies; 1490576-1 & 1583098-1)

or

any 14 ton (min) compatible proprietary equipment

Image representative of type only

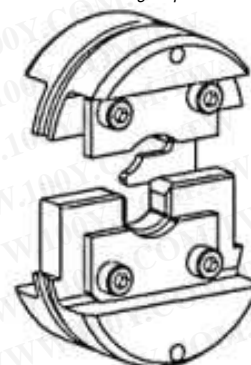

Part Number	Description	mm ² (AWG) or other
1490534-1	AMPLI-BOND and PLASTI-GRIP Terminals & Splices - Complete Die-set	10.0 (8)
1490535-1	AMPLI-BOND and PLASTI-GRIP Terminals & Splices - Complete Die-set	16.0 (6)
1490536-1	AMPLI-BOND and PLASTI-GRIP Terminals & Splices - Complete Die-set	25.0 (4)
1490410-1	AMPLI-BOND and PLASTI-GRIP Terminals & Splices - Complete Die-set	35.0 (2)
1583098-1	AMPOWER Terminals & Splices - Complete Die-set	120.0 (4/0)
1490556-1	COPALUM Sealed Terminals and Splices	Cu 10.0 (8) Al 16.0 (6)
1490557-1	COPALUM Sealed Terminals and Splices	Cu 16.0 (6) Al 25.0 (4)
1490555-1	COPALUM Sealed Terminals and Splices	Cu 8.0 (10) Al 10.0 (8)
1490573-1	COPALUM Terminals and Splices	Cu 10.0 (8) Al 16.0 (6)
1490715-1	COPALUM Terminals and Splices	Cu 10.0 (8) Al 16.0 (6)
1490574-1	COPALUM Terminals and Splices	Cu 16.0 (6) Al 25.0 (4)
1490716-1	COPALUM Terminals and Splices	Cu 16.0 (6) Al 25.0 (4)
1490575-1	COPALUM Terminals and Splices	Cu 25.0 (4) Al 35.0 (2)
1490717-1	COPALUM Terminals and Splices	Cu 25.0 (4) Al 35.0 (2)
1490576-1	COPALUM Terminals and Splices	Cu 35.0 (2) Al 50.0 (1/0)
1490718-1	COPALUM Terminals and Splices	Cu 35.0 (2) Al 50.0 (1/0)
1490572-1	COPALUM Terminals and Splices	Cu 8.0 (10) Al 10.0 (8)
1490714-1	COPALUM Terminals and Splices	Cu 8.0 (10) Al 10.0 (8)
1490406-1	TERMINYL Terminals & Splices - Complete Die-set (PLASTI-GRIP where no insulation crimp is required)	35.0 (2)
1490700-1	TERMINYL Terminals & Splices - Complete Die-set (PLASTI-GRIP where no insulation crimp is required)	50.0 (1/0)

'U' Die Nest

A range of Die Nests for heavy duty crimping

Image representative of type only

Features:

Nest outline dimensions conform to 'U' Die Industry Standard

Use in:

1490748-1 'U' Die 12 Ton Hydraulic Hand Tool

1490749-1 'U' Die 14 Ton Hydraulic Hand Tool

or

1213875-2 Battery-Hydraulic Tool Kit - 12 Ton 'U' Die

or

1901820-1 'U' Die 12 Ton Hydraulic Head

1490747-1 'U' Die 12 Ton Hydraulic Head (Titanium)

1901821-1 'U' Die 12 Ton Hydraulic Head - 1.5

or

any 12 ton (min) compatible proprietary equipment

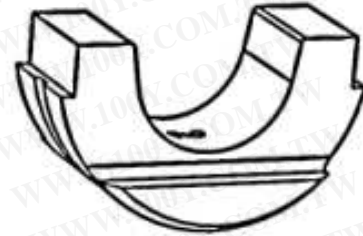

Part Number	Description	mm ² (AWG) or other
2-1490413-1	SOLISTRAND 90° Bend Ring Tongue Terminals - use with Indenter 1490414-3	100.0 - 125.0 [4/0]
1-1490413-5	SOLISTRAND 90° Bend Ring Tongue Terminals - use with Indenter 1490414-2	13.0 - 15.0 [6]
1-1490413-6	SOLISTRAND 90° Bend Ring Tongue Terminals - use with Indenter 1490414-2	21.0 [4]
1-1490413-7	SOLISTRAND 90° Bend Ring Tongue Terminals - use with Indenter 1490414-2	34.0 - 35.0 [2]
1-1490413-8	SOLISTRAND 90° Bend Ring Tongue Terminals - use with Indenter 1490414-2	59.0 - 60.0 [1/0]
1-1490413-9	SOLISTRAND 90° Bend Ring Tongue Terminals - use with Indenter 1490414-3	67.0 - 70.0 [2/0]
1-1490413-4	SOLISTRAND 90° Bend Ring Tongue Terminals - use with Indenter 1490414-1	7.0 - 8.0 [8]
2-1490413-0	SOLISTRAND 90° Bend Ring Tongue Terminals - use with Indenter 1490414-3	80.0 - 95.0 [3/0]
1752680-8	SOLISTRAND Flag Terminals - use with Indenter 1752681-2	10.0 (8)
1752680-1	SOLISTRAND Flag Terminals - use with Indenter 1752681-1	120.0 (4/0)
1752680-7	SOLISTRAND Flag Terminals - use with Indenter 1752681-3	16.0 (6)
1752680-6	SOLISTRAND Flag Terminals - use with Indenter 1752681-3	25.0 (4)
1752680-5	SOLISTRAND Flag Terminals - use with Indenter 1752681-3	35.0 (2)
1752680-4	SOLISTRAND Flag Terminals - use with Indenter 1752681-1	50.0 (1/0)
1752680-3	SOLISTRAND Flag Terminals - use with Indenter 1752681-1	70.0 (2/0)
1752680-2	SOLISTRAND Flag Terminals - use with Indenter 1752681-1	95.0 (3/0)
1-1490413-0	SOLISTRAND HD Terminals & Splices - use with Indenter 1490414-2	13.0 - 15.0 [6] HD
1-1490413-1	SOLISTRAND HD Terminals & Splices - use with Indenter 1490414-2	21.0 [4] HD
1-1490413-2	SOLISTRAND HD Terminals & Splices - use with Indenter 1490414-3	34.0 - 35.0 [2] HD
1-1490413-3	SOLISTRAND HD Terminals & Splices - use with Indenter 1490414-3	59.0 - 60.0 [1/0] HD
1490413-9	SOLISTRAND HD Terminals & Splices - use with Indenter 1490414-2	7.0 - 8.0 [8] HD
1490413-8	SOLISTRAND; STRATO-THERM SOLISTRAND Terminals & Splices - use with Indenter 1490414-3	100.0 - 125.0 [4/0]
1490413-2	SOLISTRAND; STRATO-THERM SOLISTRAND Terminals & Splices - use with Indenter 1490414-2	13 - 15 [6]
1490413-3	SOLISTRAND; STRATO-THERM SOLISTRAND Terminals & Splices - use with Indenter 1490414-2	21.0 (4)
1490413-4	SOLISTRAND; STRATO-THERM SOLISTRAND Terminals & Splices - use with Indenter 1490414-2	34.0 - 35.0 [2]
1490413-5	SOLISTRAND; STRATO-THERM SOLISTRAND Terminals & Splices - use with Indenter 1490414-3	59.0 - 60.0 [1/0]
1490413-6	SOLISTRAND; STRATO-THERM SOLISTRAND Terminals & Splices - use with Indenter 1490414-3	67.0 - 70.0 [2/0]
1490413-1	SOLISTRAND; STRATO-THERM SOLISTRAND Terminals & Splices - use with Indenter 1490414-1	7.0 - 8.0 [8]
1490413-7	SOLISTRAND; STRATO-THERM SOLISTRAND Terminals & Splices - use with Indenter 1490414-3	80.0 - 95.0 [3/0]

'U' Die Indenter

A range of Indenters for Heavy Duty crimping

Image representative of type only

Features:

Indenter outline dimensions conform to 'U' Die Industry Standard
Use in:

1490748-1 'U' Die 12 Ton Hydraulic Hand Tool

1490749-1 'U' Die 14 Ton Hydraulic Hand Tool

or

1213875-2 Battery-Hydraulic Tool Kit - 12 Ton 'U' Die

or

1901820-1 'U' Die 12 Ton Hydraulic Head

1490747-1 'U' Die 12 Ton Hydraulic Head (Titanium)

1901821-1 'U' Die 12 Ton Hydraulic Head - 1.5

or

any 12 ton (min) compatible proprietary equipment

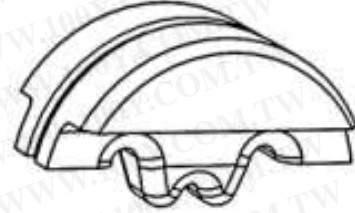

Part Number	Description	mm ² (AWG) or other
1490414-2	SOLISTRAND & HD; STRATO-THERM SOLISTRAND; SOLISTRAND 90° Bend Terminals & Splices	13.0 - 35.0 [6-2] 7.0 - 21.0 [8-4] HD
1490414-3	SOLISTRAND & HD; STRATO-THERM SOLISTRAND; SOLISTRAND 90° Bend Terminals & Splices	59.0 - 125.0 [1/0-4/0] 34.0 - 60 [2-1/0]HD
1490414-1	SOLISTRAND & HD; STRATO-THERM SOLISTRAND; SOLISTRAND 90° Bend Terminals & Splices	7.0 - 8.0 [8] 7.0 - 8.0 [8] HD
1752681-2	SOLISTRAND Flag Terminals - use with nest 1752680-8	10.0 (8)
1752681-3	SOLISTRAND Flag Terminals - use with nests; 1752680-5, 1752680-6, 1752680-7	16.0 - 35.0 (6-2)
1752681-1	SOLISTRAND Flag Terminals - use with nests; 1752680-1, 1752680-2, 1752680-3, 1752680-4	50.0 - 120.0 (1/0-4/0)
1901657-3	SOLISTRAND HD Seamless Ring Tongue Terminals & Butt Splices use with Nests; 1-1490413-8, 1- -9, 2- -0, 2- -1	[1/0-4/0]
1901657-2	SOLISTRAND HD Seamless Ring Tongue Terminals & Butt Splices use with Nests; 1-1490413-5, 1- -6, 1- -7	[6-1]
1901657-1	SOLISTRAND HD Seamless Ring Tongue Terminals & Butt Splices use with Nest 1-1490413-4	[8]

'U' Die 12 Ton Hydraulic Hand Tool

Suitable for ALL 'U' Dies - with the exception of 'U' Die Assy (14 ton)

Image representative of type only

Features:

36.5mm (1.2") stroke for faster crimping

Pump action die closure

Circa 20,000 cycles



Part Number	Description	mm ² (AWG) or other
1490748-1	Tool without Die-set (U Die alternative to 59974-1)	12 Ton U Dies only

'U' Die 14 Ton Hydraulic Hand Tool

Suitable for ALL 'U' Dies

Features:

- 38mm (1.5") stroke
- Pump action die closure
- Circa 20,000 cycles

Image representative of type only



Part Number	Description	mm ² (AWG) or other
1490749-1	Tool without Die-set (U Die alternative to 59973-1)	Any U Die

'U' Die 12 Ton Hydraulic Head

Suitable for ALL 'U' Dies - with the exception of 'U' Die Assy (14 ton)

Features:

- 36.5mm (1.2") stroke for fast cycle
- Rated for use with 700 bar (10,000 psi) pump units
- Circa 20,000 cycles

Image representative of type only



Use with:

- Optional Hose Assemblies; 1583662-1, 1583662-2 or 1583662-3 Respectively; 1.83 M (6'), 3 M (10'), 6.1 M (20')
- Hand Pump 1583661-1
- Foot Pump 1583659-1
- Electric-Hydraulic Pumps; 1804700-2, 523199-1

Part Number	Description	mm ² (AWG) or other
1490745-1	Head without dies 25.4mm (1") stroke (U Die alternative to 69051)	
1490747-1	Lightweight Titanium Head without dies (U Die alternative to 69051)	12 Ton U Dies only

Battery-Hydraulic Tool Kit - 12 Ton 'U' Die

Suitable for ALL 'U' Dies - with the exception of 'U' Die Assy (14 ton)

Features:

- Rotating Head 320°
- Excellent power to weight ratio
- Circa 10,000 Cycles

Image representative of type only



Kit Includes:

- Crimp Tool
- Battery Charger 220v (PN 1213873-2)
- Rechargeable Battery (PN 1213872-1)
- Carry Case with strap

Part Number	Description	mm ² (AWG) or other
1213875-2	Complete Kit with EU Power Plug	12 Ton U Dies only

'U' Die 14 Ton Hydraulic Head

Suitable for ALL 'U' Dies

Features:

- 38mm (1.5") Stroke
- Rated for use with 700 bar (10,000 psi) pump units
- Rated for 20,000 cycles

Use with:

- Optional Hose Assemblies; 1583662-1, 1583662-2 or 1583662-3 Respectively; 1.83 M (6'), 3 M (10'), 6.1 M (20')
- Hand Pump 1583661-1
- Foot Pump 1583659-1
- Electric-Hydraulic Pumps; 1804700-2, 523199-1

Image representative of type only



Part Number	Description	mm ² (AWG) or other
1490746-1	Head without dies 38mm (1.5") stroke (U Die alternative to 69051)	Any U Die

'U' Die 14 Ton Hydraulic Head - Latched

Suitable for ALL 'U' Dies

Features:

- Latched Head for added strength
- 38mm (1.5") Stroke
- Rated for use with 700 bar (10,000 psi) pump units

Use with:

- Optional Hose Assemblies; 1583662-1, 1583662-2 or 1583662-3 Respectively; 1.83 M (6'), 3 M (10'), 6.1 M (20')
- Hand Pump 1583661-1
- Foot Pump 1583659-1
- Electric-Hydraulic Pumps; 1804700-2, 523199-1

Image representative of type only



Part Number	Description	mm ² (AWG) or other
1976230-1	Head (Latched) without Dies	Any U Die

Dies for Battery Tool Kit - 4 Ton Latch Head

Image representative of type only

Features:

Use in:

1901343-2 Battery Tool Kit with retract switch (EU power plug)

1901343-4 Battery Tool Kit without retract switch (EU power plug)

Part Number	Description	mm ² (AWG) or other
1976977-1	Die-set for PIDG STRATO-THERM Terminals & Splices with PTFE or PEEK thin-wall Insulation	4.0 (12)
1976976-1	Die-set for PIDG STRATO-THERM Terminals & Splices with PTFE or PEEK thin-wall Insulation	6 (10.0)
1901001-1	Die-Nest for SOLISTRAND Terminals & Splices - use with Indenter 1901002-2	10.0 (8)
1901002-2	Die-Indenter for SOLISTRAND Terminals & Splices - use with Nest 1901001-1	10.0 (8)
1901002-1	Die-Indenter for SOLISTRAND Terminals & Splices - use with Nest's; 1901000-1, 1901000-2, 1901000-3	16.0 - 35 (6-2)
1901000-1	Die-Nest for SOLISTRAND Terminals & Splices - use with Indenter 1901002-1	16.0 (6)
1901000-2	Die-Nest for SOLISTRAND Terminals & Splices - use with Indenter 1901002-1	25.0 (4)
1901000-3	Die-Nest for SOLISTRAND Terminals & Splices - use with Indenter 1901002-1	35.0 (2)
1901006-1	Die-set for TERMINYL Terminals & Splices; (PLASTI-GRIP where no insulation crimp is required)	10.0 (8) Red
1901007-1	Die-set for TERMINYL Terminals & Splices; (PLASTI-GRIP where no insulation crimp is required)	16.0 (6) Blue

Battery Tool Kit - 4 Ton Latch Head

Ideal for low to medium production volumes

Features:

Over 80 crimps per charge

Compact - only 356mm (14") long and weighs 1.6 kg (3.5lbs)

The Tool Kit is supplied in a durable plastic Carry Case and includes:

Battery Tool with Latched Head

Battery Charger 220v

Two Batteries

Spares

Battery Charger 220v (PN 1725840-2) EU power plug

Rechargeable Battery (PN 1725839-1)

Image representative of type only

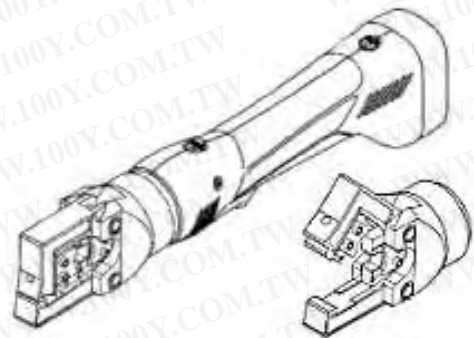

Part Number	Description	mm ² (AWG) or other
1901343-2	Battery Tool Kit - 4 Ton Latch Head with retract switch (EU power plug)	
1901343-4	Battery Tool Kit - 4 Ton Latch Head without retract switch (EU power plug)	

Die-set - Hydraulic Head Open (Shank Die)

Image representative of type only

Features:

Can be used with

Head 1752868-1 - 700 bar (10,000 psi)

or

Head 69099 - 580 bar (8,200 psi)



Part Number	Description	mm ² (AWG) or other
68044	COPALUM Terminals and Splices	Cu 10.0 (8) Al 16.0 (6)
68085	COPALUM Terminals and Splices	Cu 10.0 (8) Al 16.0 (6)
68045	COPALUM Terminals and Splices	Cu 16.0 (6) Al 25.0 (4)
68086	COPALUM Terminals and Splices	Cu 16.0 (6) Al 25.0 (4)
68046	COPALUM Terminals and Splices	Cu 25.0 (4) Al 35.0 (2)
68130	COPALUM Terminals and Splices	Cu 25.0 (4) Al 35.0 (2)
68047	COPALUM Terminals and Splices	Cu 35.0 (2) Al 50.0 (1/0)
68131	COPALUM Terminals and Splices	Cu 35.0 (2) Al 50.0 (1/0)
68048	COPALUM Terminals and Splices	Cu 50.0 (1/0) Al 70.0 (2/0)
68132	COPALUM Terminals and Splices	Cu 50.0 (1/0) Al 70.0 (2/0)
68049	COPALUM Terminals and Splices	Cu 70.0 (2/0) Al 95.0 (3/0)
68133	COPALUM Terminals and Splices	Cu 70.0 (2/0) Al 95.0 (3/0)
68043	COPALUM Terminals and Splices	Cu 8.0 (10) Al 10.0 (8)
68084	COPALUM Terminals and Splices	Cu 8.0 (10) Al 10.0 (8)
318106-1	COPALUM Terminals and Splices	Cu 95.0 (3/0) Al 120.0 (4/0)
69216	SOLISTRAND Terminals & Splices	10.0 (8)
45445	SOLISTRAND Terminals & Splices	120.0 (4/0)
69217	SOLISTRAND Terminals & Splices	16.0 (6)
69218	SOLISTRAND Terminals & Splices	25.0 (4)
45433	SOLISTRAND Terminals & Splices	35.0 (2)
45436	SOLISTRAND Terminals & Splices	50.0 (1/0)
45439	SOLISTRAND Terminals & Splices	70.0 (2/0)
45442	SOLISTRAND Terminals & Splices	95.0 (3/0)
69211-1	STRATO-THERM Post Insulated Terminals & Splices	10.0 (8)
69212-1	STRATO-THERM Post Insulated Terminals & Splices	16.0 (6)
69213-1	STRATO-THERM Post Insulated Terminals & Splices	25.0 (4)
69214-1	STRATO-THERM Post Insulated Terminals & Splices	35.0 (2)
69215-1	STRATO-THERM Post Insulated Terminals & Splices	50.0 (1/0)
69254-1	STRATO-THERM Post Insulated Terminals & Splices	70.0 (2/0)

Hydraulic Head Open (Shank Die)

Features:

Rated for use with 700 bar (10,000 psi) pump units

Use with:

Optional Hose Assemblies; 1583662-1, 1583662-2 or 1583662-3
Respectively; 1.83 M (6'), 3 M (10'), 6.1 M (20')

Hand Pump 1583661-1

Foot Pump 523199-2

Electric-Hydraulic Pumps; 1804700-2, 523199-1

Image representative of type only



Part Number Description

1752868-1 Hydraulic Head without Die-set (700 bar equivalent of 69099)

mm² (AWG) or other

Hydraulic Head Open - Dyna-Crimp

Features:

Rated for use with 580 bar (8,200 psi) pump units

Use with:

Optional Hose Assemblies; 59909-7, 1-59909-5 or 2-59909-1
Respectively; 2.12 M (7'), 4.58 M (15') 6.4 M (21')

Hand Pump 314979-1

Foot Pump 523199-3

Electric-Hydraulic Pump; 69120-2

Image representative of type only



Part Number Description

69099 Hydraulic Head without Die-Set

mm² (AWG) or other

Die-set - Hydraulic Head Closed (Shank Die)

Features:

Use in Heads:

1752787-1 & 1752877-1 - 700 bar (10,000 psi)

or

Dynacrimp Heads:

58422-1 & 69066 - 580 bar (8,200 psi)

Dies listed with * can only be used in Heads:

1752787-1 & 58422-1

see also relevant Die Instruction Sheet for more details

Image representative of type only



Part Number	Description	mm ² (AWG) or other
48860-1	AMPLI-BOND and PLASTI-GRIP Terminals and Splices	25.0 (4)
48861-1	AMPLI-BOND and PLASTI-GRIP Terminals & Splices	35.0 (2)
314948-1	* COPALUM Sealed Terminals and Splices	120.0 (4/0)
68007	COPALUM Sealed Terminals and Splices	Cu 10.0 (8) Al 16.0 (6)
68008	COPALUM Sealed Terminals and Splices	Cu 16.0 (6) Al 25.0 (4)
68009	COPALUM Sealed Terminals and Splices	Cu 25.0 (4) Al 35.0 (2)
68010-1	COPALUM Sealed Terminals and Splices	Cu 35.0 (2) Al 50.0 (1/0)
68011-1	* COPALUM Sealed Terminals and Splices	Cu 50.0 (1/0) Al 70.0 (2/0)
314964-1	COPALUM Sealed Terminals and Splices	Cu 50.0 (1/0) Al 70.0 (2/0)
59877-1	* COPALUM Sealed Terminals and Splices	Cu 70.0 (2/0) Al 95.0 (3/0)
68006	COPALUM Sealed Terminals and Splices	Cu 8.0 (10) Al 10.0 (8)
47824	TERMINYL Terminals & Splices (PLASTI-GRIP where no insulation crimp is required)	50.0 (1/0)
47825	TERMINYL Terminals & Splices (PLASTI-GRIP where no insulation crimp is required)	70.0 (2/0)

Hydraulic Head Closed (Shank Die)

Features:

Rated for use with 700 bar (10,000 psi) pump units

Use with:

Optional Hose Assemblies; 1583662-1, 1583662-2 or 1583662-3
Respectively; 1.83 M (6'), 3 M (10'), 6.1 M (20')

Hand Pump 1583661-1

Foot Pump 523199-2

Electric-Hydraulic Pumps; 1804700-2, 523199-1

Image representative of type only



1752787-1

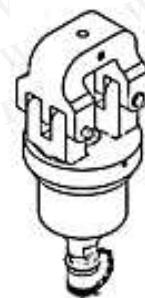

1752877-1

Part Number	Description	mm ² (AWG) or other
1752787-1	Hydraulic Head without Die-set (700 bar equivalent of 58422-1)	
1752877-1	Hydraulic Head without Die-set (700 bar equivalent of 69066) - lighter than 1752787-1	

Hydraulic Head Closed - Dyna-Crimp

Features:

Rated for use with 580 bar (8,200 psi) pump units

Use with:

Optional Hose Assemblies; 59909-7, 1-59909-5 or 2-59909-1
Respectively; 2.12 M (7'), 4.58 M (15') 6.4 M (21')

Hand Pump 314979-1

Foot Pump 523199-3

Electric-Hydraulic Pump; 69120-2

Image representative of type only



Part Number	Description	mm ² (AWG) or other
58422-1	Head without dies	
69066	Head without dies - lighter than 58422-1	

Die-set - Hydraulic Head Open (Shank Die H'Duty)

Features:

Can be used with

Head 1752786-1 - 700 bar (10,000 psi)

or

Head 69082 - 580 bar (8,200 psi)

Image representative of type only



Part Number	Description	mm ² (AWG) or other
46760-2	AMPOWER Terminals & Splices	1,000 MCM HD
69653	AMPOWER Terminals and Splices	350 MCM
46754-2	AMPOWER Terminals & Splices	400 MCM
46755-2	AMPOWER Terminals & Splices	500 MCM
46756-2	AMPOWER Terminals & Splices	600 MCM
59870-1	AMPOWER Terminals and Splices	600 MCM HD
46757-2	AMPOWER Terminals & Splices	700 MCM
46758-2	AMPOWER Terminals & Splices	800 MCM
46759-2	AMPOWER Terminals & Splices	900 MCM
68034	COPALUM Terminals and Splices	Cu 120.0 (4/0) Al 250 MCM
68035	COPALUM Terminals and Splices	Cu 250 MCM Al 300 MCM
68036	COPALUM Terminals and Splices	Cu 300 MCM Al 400 MCM
68037	COPALUM Terminals and Splices	Cu 400 MCM Al 500 MCM
68050	COPALUM Terminals and Splices	Cu 95.0 (3/0) Al 120.0 (4/0)
68129	COPALUM Terminals and Splices	Cu 95.0 (3/0) Al 120.0 (4/0)
69911	SOLISTRAND Terminals & Splices	250 - 300 MCM
69912	SOLISTRAND Terminals & Splices	300 - 350 MCM
69913	SOLISTRAND Terminals & Splices	400 MCM
69914	SOLISTRAND Terminals & Splices	500 - 600 MCM

Hydraulic Head Open (Shank Die Heavy Duty)

Features:

Rated for use with 700 bar (10,000 psi) pump units

Use with:

Optional Hose Assemblies; 1583662-1, 1583662-2 or 1583662-3
Respectively; 1.83 M (6'), 3 M (10'), 6.1 M (20')

Hand Pump 1583661-1

Foot Pump 523199-2

Electric-Hydraulic Pumps; 1804700-2, 523199-1

Image representative of type only



Part Number	Description
-------------	-------------

1752786-1	Hydraulic Head without Die-set (700 bar equivalent of 69082)
-----------	--

mm² (AWG) or other

Hydraulic Head Open (Heavy Duty) - Dyna-Crimp

Features:

Rated for use with 580 bar (8,200 psi) pump units

Use with:

Optional Hose Assemblies; 59909-7, 1-59909-5 or 2-59909-1
Respectively; 2.12 M (7'), 4.58 M (15') 6.4 M (21')

Hand Pump 314979-1

Foot Pump 523199-3

Electric-Hydraulic Pump; 69120-2

Image representative of type only



Part Number	Description
-------------	-------------

69082	Head without dies
-------	-------------------

mm² (AWG) or other

Die-set - Hydraulic Head Closed (Shank Die H'Duty)

Features:

Can be used with

Head 1752788-1 - 700 bar (10,000 psi)

or

Head 58445-1 - 580 bar (8,200 psi)

Image representative of type only



Part Number	Description	mm ² (AWG) or other
-------------	-------------	--------------------------------

48816	SOLISTRAND Terminals & Splices	250 - 300 MCM
-------	--------------------------------	---------------

48817	SOLISTRAND Terminals & Splices	300 - 350 MCM
-------	--------------------------------	---------------

48818	SOLISTRAND Terminals & Splices	400 MCM
-------	--------------------------------	---------

48819	SOLISTRAND Terminals & Splices	500 - 600 MCM
-------	--------------------------------	---------------

Hydraulic Head Closed (Shank Die Heavy Duty)

Features:

Rated for use with 700 bar (10,000 psi) pump units

Use with:

Optional Hose Assemblies; 1583662-1, 1583662-2 or 1583662-3
Respectively; 1.83 M (6'), 3 M (10'), 6.1 M (20')

Hand Pump 1583661-1

Foot Pump 523199-2

Electric-Hydraulic Pumps; 1804700-2, 523199-1

Image representative of type only



Part Number Description

1752788-1 Heavy Duty Hydraulic Head without Die-set (700 bar equivalent of 58445-1)

mm² (AWG) or other

Hydraulic Head Closed (Heavy duty) - Dyna-Crimp

Features:

Rated for use with 580 bar (8,200 psi) pump units

Use with:

Optional Hose Assemblies; 59909-7, 1-59909-5 or 2-59909-1
Respectively; 2.12 M (7'), 4.58 M (15') 6.4 M (21')

Hand Pump 314979-1

Foot Pump 523199-3

Electric-Hydraulic Pump; 69120-2

Image representative of type only



Part Number Description

58445-1 Head without dies

mm² (AWG) or other

Battery-Hydraulic Tool 100 KN

1-1579002-9 with closed head design

The listed Hex crimp Dies conform to DIN 48083

Lugs to be applied should conform to DIN 46235

Image representative of type only

Features:

Fast battery re-charge in 15 minutes

50 cycles approx. with one charge

Rotating head for easy access

Kit Includes: (Spare part PN)

Tool + Head

Battery charger (7-1579005-7)

Battery (7-1579005-8)

Carry Case (8-1579005-0)

Foam inlay (8-1579005-1)



Option:

Bench-mount 7-1579005-9

Part Number	Description	mm ² (AWG) or other
3-1579009-1	Die-set - Indent Crimp for Cable Lugs	10.0 (8)
5-1579009-4	Die-set - Indent Crimp for Cable Lugs	120.0 (4/0)
3-1579009-2	Die-set - Indent Crimp for Cable Lugs	16.0 mm ²
3-1579009-3	Die-set - Indent Crimp for Cable Lugs	25.0 (4)
5-1579009-1	Die-set - Indent Crimp for Cable Lugs	25.0 (4)
3-1579009-4	Die-set - Indent Crimp for Cable Lugs	35.0 (2)
3-1579009-5	Die-set - Indent Crimp for Cable Lugs	50.0 mm ²
5-1579009-2	Die-set - Indent Crimp for Cable Lugs	6.0 (10)
3-1579009-6	Die-set - Indent Crimp for Cable Lugs	70.0 mm ²
5-1579009-3	Die-set - Indent Crimp for Cable Lugs	95.0 mm ²
1-1579009-6	Die-set - 7mm thick; Hex Crimp for Tubular & Cast Cable/Battery Lugs	Al 300 mm ²
1579009-3	Die-set - 7mm thick; Hex Crimp for Tubular & Cast Cable/Battery Lugs	Cu 10 mm ²
1-1579009-7	Die-set - 14mm thick; Hex Crimp for Tubular & Cast Cable/Battery Lugs	Cu 10 mm ²
1-1579009-0	Die-set - 7mm thick; Hex Crimp for Tubular & Cast Cable/Battery Lugs	Cu 120 mm ²
2-1579009-4	Die-set - 14mm thick; Hex Crimp for Tubular & Cast Cable/Battery Lugs	Cu 120 mm ²
1-1579009-2	Die-set - 7mm thick; Hex Crimp for Tubular & Cast Cable/Battery Lugs	Cu 150 mm ² ; Al 95-120 mm ²
2-1579009-5	Die-set - 14mm thick; Hex Crimp for Tubular & Cast Cable/Battery Lugs	Cu 150 mm ² ; Al 95-120 mm ²
1579009-4	Die-set - 7mm thick; Hex Crimp for Tubular & Cast Cable/Battery Lugs	Cu 16 mm ² ; Al 10 mm ²
1-1579009-8	Die-set - 14mm thick; Hex Crimp for Tubular & Cast Cable/Battery Lugs	Cu 16 mm ² ; Al 10 mm ²
1-1579009-3	Die-set - 7mm thick; Hex Crimp for Tubular & Cast Cable/Battery Lugs	Cu 185 mm ² ; Al 150 mm ²
2-1579009-6	Die-set - 14mm thick; Hex Crimp for Tubular & Cast Cable/Battery Lugs	Cu 185 mm ² ; Al 150 mm ²
1-1579009-4	Die-set - 7mm thick; Hex Crimp for Tubular & Cast Cable/Battery Lugs	Cu 240 mm ² ; Al 185 mm ²
2-1579009-7	Die-set - 14mm thick; Hex Crimp for Tubular & Cast Cable/Battery Lugs	Cu 240 mm ² ; Al 185 mm ²
1579009-5	Die-set - 7mm thick; Hex Crimp for Tubular & Cast Cable/Battery Lugs	Cu 25 mm ²
1-1579009-9	Die-set - 14mm thick; Hex Crimp for Tubular & Cast Cable/Battery Lugs	Cu 25 mm ²
1-1579009-5	Die-set - 7mm thick; Hex Crimp for Tubular & Cast Cable/Battery Lugs	Cu 300 mm ² ; Al 240 mm ²
2-1579009-8	Die-set - 14mm thick; Hex Crimp for Tubular & Cast Cable/Battery Lugs	Cu 300 mm ² ; Al 240 mm ²
1579009-6	Die-set - 7mm thick; Hex Crimp for Tubular & Cast Cable/Battery Lugs	Cu 35 mm ² ; Al 16-25 mm ²
2-1579009-0	Die-set - 14mm thick; Hex Crimp for Tubular & Cast Cable/Battery Lugs	Cu 35 mm ² ; Al 16-25 mm ²
1579009-7	Die-set - 7mm thick; Hex Crimp for Tubular & Cast Cable/Battery Lugs	Cu 50 mm ² ; Al 35 mm ²
2-1579009-1	Die-set - 14mm thick; Hex Crimp for Tubular & Cast Cable/Battery Lugs	Cu 50 mm ² ; Al 35 mm ²
1579009-8	Die-set - 7mm thick; Hex Crimp for Tubular & Cast Cable/Battery Lugs	Cu 70 mm ² ; Al 50 mm ²
2-1579009-2	Die-set - 14mm thick; Hex Crimp for Tubular & Cast Cable/Battery Lugs	Cu 70 mm ² ; Al 50 mm ²
1579009-9	Die-set - 7mm thick; Hex Crimp for Tubular & Cast Cable/Battery Lugs	Cu 95 mm ² ; Al 70 mm ²
2-1579009-3	Die-set - 14mm thick; Hex Crimp for Tubular & Cast Cable/Battery Lugs	Cu 95 mm ² ; Al 70 mm ²

Heavy duty Electric Hydraulic Pump

Features:

Built for continuous use
 Tank capacity = 11.37 liters (2.5 gallons)
 Weight = 25 kg (65 Lbs)
 90-95 dBA

Accessories - see 409-10081

Image representative of type only



Part Number	Description	mm ² (AWG) or other
69120-2	Heavy duty Electric Hydraulic Pump - 580 Bar (8,200 psi) 220v	
1804700-2	Heavy duty Electric Hydraulic Pump - 700 Bar (10,000 psi) 220v	

Electric Hydraulic Pump, light duty

Features:

Lightweight and compact design 10 kg
 Large Carry-handle for easy portability
 Two speed cycle reduces cycle time for improved productivity
 24 v DC remote motor control, 3m length for operator safety
 Starts under full load
 High strength moulded shroud
 Supplied with male quick coupler (no hose supplied)

Pressure Gauge options:
 523200-1 Pressure Gauge
 523200-2 Digital Pressure Gauge
 523200-3 1/4" Adapter (required when using either Gauge)

Image representative of type only



Part Number	Description	mm ² (AWG) or other
523199-1	Portable pump 700 bar (10,000 psi) suitable for intermittent duty cycle	

Hydraulic Hand Pump

Features:

This pump action unit allows hydraulic heads via optional length hydraulic hoses a degree of positional flexibility

Image representative of type only



Part Number	Description	mm ² (AWG) or other
1583661-1	Hand Pump 700 bar (10,000 psi)	

Hydraulic Foot Pump

580 (8,500 psi) & 700 bar (10,000 psi) options

Features:

- Pump action operation
- Clicker valve pressure regulation
- Supplied with male quick-coupling

Image representative of type only



Part Number	Description
523199-2	Max pressure rating 700 bar (10,000 psi)
523199-3	Max pressure rating 580 bar (8,500 psi)

mm² (AWG) or other

Group Cutter

1490498-1

Features:

- Suitable for Copper or Aluminum, solid or stranded to 35 mm² (2 awg) and Coax to RG 9
- Steel handles lock together for safe storage
- Non-slip plastic handle grips
- Not for Steel or ACSR cable

Image representative of type only



Cable Cutter 350 mcm

605744-1

Features:

- Suitable for Copper or Aluminum, solid or stranded to 185 mm² (350 MCM)
- Steel Handles
- Non-slip plastic handle grips
- Not for Steel or ACSR cable

Image representative of type only



Cable Cutter 500 mcm

605742-1

Features:

Suitable for Copper or Aluminum, solid or stranded to 300 mm² (500 MCM)
Fibreglass Handles
Non-slip plastic handle grips
Not for Steel or ACSR cable

Image representative of type only



Cable Cutter 350 mcm with Ratchet

1490489-1

Features:

Suitable for Copper or Aluminum, solid or stranded to 180 mm² (350 MCM)
Handles lock together for safe storage
Ratchet mechanism keeps handle force low
Non-slip plastic handle grips
Not for Steel or ACSR cable

Image representative of type only



Cable Cutter 500 mcm with Ratchet

607453-2

Features:

Suitable for Copper or Aluminum, solid or stranded to 300 mm² (500 MCM)
Fibreglass Handles
Non-slip plastic handle grips
Not for Steel or ACSR cable

Image representative of type only



Cable Cutters SH Range

A range of heavy duty Cable Cutting tools

Features:

- Very compact and lightweight
- One handed - low handle closing force
- Burr free cutting
- Lockable cutting stroke
- Non-slip plastic hand grips

Image representative of type only



Part Number	Description	mm ² (AWG) or other
734045-1	solid and stranded copper and aluminium cables	Solid Cu 185 mm ² Solid Al 185 mm ² Stranded Cu / Al Ø52 Hi Flex Cu Ø52
169415-1	Solid and stranded copper and aluminium cables	Solid Cu 185 mm ² Solid Al 240 mm ² Stranded Cu / Al Ø25 Hi Flex Cu Ø32
1-1579002-8	solid and stranded copper and aluminium cables (no ASCR)	Solid Cu 480 mm ² Solid Al 480 mm ² Stranded Cu / Al Ø54

Corex Coax Stripper

For Cables with a Jacket diameter of 2.54 to 7.62 mm

Features:

- Complete cable strip
- Easy cutter adjustment
- Simple rotary cutting motion
- Colour coded cassettes
- Pre-set strip lengths

Image representative of type only



Part Number	Description	mm ² (AWG) or other
603995-2	2 step cable stripper for Comercial BNC connectors and RG 58 / 59 / 62 cable. 6.8 mm outer jacket strip length. Spare Cassete Blue, PN 603996-2	RG 58 / 59 / 62 Cable Ø5.0-6.5mm
947489-1	3 step cable stripper for Commercial BNC connectors. 7.5 mm outer jacket & 3.5 mm dielectric strip lengths. Spare Cassete Brown PN 947490-1	RG 58 / 59 / 62 Cable Ø5.0-6.5mm
603995-5	3 step cable stripper for Dual Crimp BNC connectors. 5.5 mm outer jacket & 5.5 mm dielectric strip lengths Spare Cassete Black PN 603996-4	RG 58 / 59 / 62 Cable Ø5.0-6.5mm
603995-6	3 step cable stripper for Dual Crimp Commercial BNC connectors and RG; 174, 179, 188 & 316 cable. 6.8 mm outer jacket & 2.5 mm dielectric strip lengths. Spare Cassete White PN 603996-5	RG; 174, 179, 188 & 316 Cable Ø2.5-3.0mm
603995-1	2 step cable stripper for Single crimp BNC connectors and RG 195 / 180 cable. 6 mm outer jacket strip length. Spare Cassete Red, PN 603996-1	RG 195 / 180 Cable Ø3.0-5.0mm
603995-3	2 step cable stripper for UHF connectors and RG 6 & Belden 8281. 12 mm outer jacket strip length. Spare Cassete Yellow, PN 603996-3	RG 6 & Belden 8281 Cable Ø6.4-7.0mm

JackKnack

2119000-1 ideally used in conjunction with the TE Mod Jack tool

Features:

- Cable jacket stripper
- JackKnack clamp
- Cable filler shear
- Wire placement tool
- Ergonomic lightweight design

Image representative of type only



Coax Cable Stripper

1490490-1

Features:

3 Blades designed to strip RG 6, 58 and 59 cable in one step
Replaceable Blade Cartridges

Image representative of type only



Rotary Cable Stripper

606700-1

Features:

Works on cables up to 25 mm diameter
Circular + Straight Strip
Supplied with spare blade

Image representative of type only



Automatic Wire Stripper

734185-1

Features:

Works on PVC, THHN and THHW cable 0.08 - 6.0 (28-10)
Adjustable stripping length
Ergonomic non-slip handles
Built-in cutter

Image representative of type only



Die-cast Automatic Wire Stripper

Features:

- Adjustable strip length
- Automatic cut-depth
- Non-slip handles

Image representative of type only



Part Number	Description	mm ² (AWG) or other
1-1579002-2	for PVC, THHN and THHW cable (includes blades) Spare Blade set 3-1579005-7	0.08 - 6.0 (28-10)
4-1579002-2	for SOLARLOK Cable (includes blades) Spare Blade set 1579006-7	2.5 - 6.0 (14-10)

Small Wire Cutters

1116571-1

Used primarily when lacing / installing the tool-less Mod Jack

Image representative of type only

Features:

- Cuts wire flush
- Spring loaded handles



KT 80 Cutting Tool

654061-1 - Ideal for cutting Ribbon Cable

Features:

- Up to 64 conductors of 0.5mm² by 81.5mm wide
- Clean undistorted cut
- Built-in Guide ensures square cut

Image representative of type only



Replaceable:
Blade 658654-1
Anvil 658563-1

Cable Tie Gun

734587-1 - for Cable Ties 2.2 - 4.8 mm and thickness up to 1.6 mm

Features:

- Automatic cut-off
- Adjustable tension setting

Image representative of type only



Non-impact Punch-down Tool

Tools without impact assist

Features:

- Rubber palm grip
- Blade Storage area in the side of the Tool
- Accepts all Twist & Lock Blades

Image representative of type only



Part Number	Description
1583236-1	Tool with 110 Blade

mm² (AWG) or other
0.08 - 0.34 (28-24)

Impact Punch-down Tool

Tools with impact assist

Features:

- Rubber palm grip
- Spare blade storage
- Adjustable Hi / Low impact setting
- Accepts all standard twist & Lock blades

Image representative of type only



Part Number	Description
1583608-1	Tool with 110 Blade

mm² (AWG) or other
0.08 - 0.34 (28-24)

Premium Impact Punch-down Tool

Tools with impact assist

Features:

- Integral spot light
- Non-slip cushioned grip
- Pick hook and spudger
- Spare blade storage
- Adjustable impact force
- Accepts all standard twist & Lock blades

Image representative of type only



Part Number	Description	mm ² (AWG) or other
1375308-1	Tool with 110 Blade 1375309-1 Spare 110 Blade	0.08 - 0.34 (28-24)
1375308-4	Tool with 066 / 110 Blade 1375310-1 Spare 066 / 110 Blade	0.08 - 0.34 (28-24)

Professional Hand Tool

2-231652-0 - Base Tool without Die-set

Features:

- Interchangeable Dies for all but 10 posn. plugs
- Terminates both strain reliefs and inserts contacts in one motion
- Ratchet mechanism ensures complete crimp cycle
- Cuts, strips and terminates
- Compatible with many other leading brand products
- AMP plugs are UL approved when terminated using this tool

Image representative of type only



Part Number	Description	mm ² (AWG) or other
2-231652-8	Complete tool for MODULAR PLUG connectors	4 & 6 Posn Line
853400-8	Die-set for MODULAR PLUG connectors Use in Hand Tool Frame 2-231652 or Economy Tool 1490496-1	4 & 6 Posn Line
2-231652-3	Complete tool for MODULAR PLUG connectors	4 Posn Hand-set
853400-3	Die-set for MODULAR PLUG connectors Use in Hand Tool Frame 2-231652 or Economy Tool 1490496-1	4 Posn Hand-set
2-231652-6	Complete tool for MODULAR PLUG connectors	6 Position off-set Flat, Oval & Round - Solid & Stranded
2-231652-7	Complete tool for MODULAR PLUG connectors	6 posn Long Body Flat, Oval & Round - Solid & Stranded
853400-7	Die-set for MODULAR PLUG connectors - Flat oval & Round - Solid or Stranded Use in Hand Tool Frame 2-231652 or Economy Tool 1490496-1	6 Posn Long Body Flat, Oval & Round - Solid or Stranded
853400-6	Die-set for MODULAR PLUG connectors - Flat oval & Round - Solid or Stranded Use in Hand Tool Frame 2-231652 or Economy Tool 1490496-1	6 Posn off-set Flat, Oval & Round - Solid or Stranded
3-231652-0	Complete tool for MODULAR PLUG connectors	8 Posn High Performance CAT 5 Cable
1-853400-0	Die-set for MODULAR PLUG connectors - CAT 5 cable Use in Hand Tool Frame 2-231652 or Economy Tool 1490496-1	8 Posn High Performance CAT 5 cable
2-231652-1	Complete tool for MODULAR PLUG connectors	8 Posn Long Body
853400-1	Die-set for MODULAR PLUG connectors Use in Hand Tool Frame 2-231652 or Economy Tool 1490496-1	8 Posn Long Body

Mod Jack Tool

Tool & Lacing Fixture combinations for rear entry cable Jacks.

Features:

- Buit-in cable stripper
- Terminates and cuts all conductors in one go
- Very small breakouts can be achieved
- Comes in a convenient Draw-string Pouch

Can be used on CAT 3 , 5 & 6 cable with:
 Rear cable entry 110 SL Series Jacks
 Rear cable entry AMP TWIST 6S SL Jacks

Image representative of type only



Part Number	Description	mm ² (AWG) or other
1673956-1	Lacing Fixture for rear cable entry 110 SL series Jacks. Use in Base Tool & Pouch 1725150-3	0.2 (24) stranded 0.2-0.4 (24-22) solid
1725150-1	Base tool, Pouch & Lacing Fixture 1673956-1 for rear cable entry 110 SL series Jacks	0.2 (24) stranded 0.2-0.4 (24-22) solid
1725150-3	Base tool & Pouch for rear cable entry AMP TWIST 6S SL series Jacks. NO Lacing Fixture required	0.2 (24) stranded 0.2-0.4 (24-22) solid

Crimping Kit for Modular Plugs

Features:

- 2-231652-0 Professional hand Tool
- 231662-1 Blade Replacement Kit
- Screw Driver
- Rhobust plastic Carry Case
- Dies for specified Plug types

Image representative of type only



Part Number	Description	mm ² (AWG) or other
1-231666-0	Standard Kit for Shielded & Non-shielded Plugs	4, 6 & 8 Posn. Line
1-231666-3	Professional Kit for Shielded & Non-shielded Plugs	4, 6 & 8 Posn. Line 6 Posn. Long Body 4 Posn. Telephone Plug
1-231666-1	Standard Kit for Shielded & Non-shielded Plugs	4-6, 8 Posn. 4 Posn. Handset

Tone Generator

1490531-1

1673606-1 - includes 1490531-1 plus Tone Tracer 1490533-1 in handy Two Pocket Pouch

Image representative of type only

Features:

Three built-in tones

Auto off

Separate talk battery for increased voltage and power for test sets

Modular Jack allows multiple cord sets to be used for different applications



Tone Tracer

1490533-1

1673606-1 - includes 1490533-1 plus Tone Generator 1490531-1 in handy Two Pocket Pouch

Image representative of type only

Features:

Detection without direct cable or wire contact

Ergonomically shaped

Can be used with any Tone Generator

Replacement quick change tips available



4-Pair Tester

1490530-1

Features:

Tests for opens, shorts, mis-wires, reversals and split pairs

Auto on/off

Battery low indicator

Image representative of type only



SUPER CHAMP II

Tools for service & repair

Features:

Made from high quality special steel for long life
Fitted with plastic comfort handles

Image representative of type only



Part Number	Description	mm ² (AWG) or other
169111-1	Open Barrel Terminals 'F' crimp Crimp widths; 2.2, 2.4, 2.8, 3.2, 3.8 & 4.8mm Wire strippers for 0.5-0.75, 1.0, 1.5, 2.5, 4 & 6mm	0.4 - 6.0 (22-10)
169060-8	PIDG, PLASTI-GRIP - All Types Bolt cutters for 3, 3.5, 4 & 5mm bolts Wire strippers for 0.5-0.75, 1.0, 1.5, 2.5, 4 & 6mm	0.26 - 6.6 (24-10)

SUPER CHAMP FT

720781-3 - for service & repair with Bulkhead Series and PIDG & PLASTIGRIP Terminals

Image representative of type only

Features:

Made from high quality special steel for long life
Fitted with plastic comfort handles

Bulkhead Series Terminals

0.3 mm²

0.5 - 0.85 mm²

1.25 - 2.0 mm²

PIDG & PLASTIGRIP

RBY 0.5 - 6mm² (22-10)

General wire strippers



CRIMPAC CG

734372-1 - Base Tool without dies

Features:

- Toggle lever handle force adjuster with quick release
- Cable cutting device 0.5 - 6 mm² (21-10)
- Wire stripping device 0.5 - 6 mm² (21-10)

Image representative of type only



Part Number	Description	mm ² (AWG) or other
825582-2	Complete tool for CI-2; MATE-N-LOK 3.5; Standard TIMER AMLIVERSAL Logo	0.5 - 5.3 (20-10)
825582	Complete tool for CI-2; MATE-N-LOK 3.5; Standard TIMER	0.5 - 5.3 (20-10)
825508-5	Complete tool for PIDG & PLASTI-GRIP Terminals	0.5 - 6.0 (20-10)
734481-1	Die-set for PIDG, PLASTI-GRIP - All Types Use in Hand Tool Frame 734372-1	0.6 - 6.0 (22-10)

Die-set - SDE for Fibre Optic Connectors

SDE Dies allow Hand or Powered options

Features:

- Use in:
- SDE PRO-CRIMPER III Hand Tool 354940-1
- SDE PEW 12 Hand Tool 9-1478240-0
- SDE DA Hand Tool 1213745-1
- SDE BATTERY TOOL (Kit) 1725837-2 for shoulder dies
- SDE 626 Head 679304-1 + accessories
- SDE Electric Terminator 1490076-2
- SDE Bench Press Adapter 1579000-8 + Press 1481004-7

Image representative of type only



Part Number	Description	mm ² (AWG) or other
91900-1	HTS Fibre Optic contact HD-LWL series	

Dual Purpose Butterfly Tool

Mass termination tool for AMP CHAMP products

Features:

- Mass terminates and shears all wires in a single action
- Can be fixed by screws to a bench
- Supplied in a carrying case

Image representative of type only



Part Number	Description	mm ² (AWG) or other
229378-1	Standard tool for AMP CHAMP	14, 24, 36 & 50 Posn
231880-1	Standard tool for AMP CHAMP	64 Posn

AF8

601967-1 AF8 [M22520/1-01] Crimp Tool without Turret
 2031846-1 WA27F (Pneumatic AF8) without Turret

Image representative of type only

Features:

- 4/8 indent Crimp to Military standard
- Ratchet mechanism ensures complete crimp cycle
- 8 Position Dial select Indent Depth control
- Many Turrets available
- Ergonomic non-slip handles



AF8 - Turret

Accurately positions Contacts in the Tool

Image representative of type only

Features:

- Data plate shows compatible Contacts and settings

Use in:

- 601967-1 - AF8 Base Tool without Turret
- 2031846-1 - Pneumatic AF8 (WA27F) without Turret



Part Number	Description	mm ² (AWG) or other
601967-5	Universal Head UH2-5 [M22520/1-05]	
601967-9	Turret TH45	0.15 - 1.5 (26-16)
601967-2	Turret TH1A [M22520/1-02] for ARINC contacts	0.15 - 4.0 (26-12)
1-601967-2	Single Position Head TP465 [M22520/1-11] for M39029	2.5 - 4.0 (14-12)
601967-4	Turret TH4 [M22520/1-03] for MS17803; MS21097; OSI2814 contacts	0.15 - 1.5 (26-16)
601967-7	Turret TP85 [M22520/1-07] for MS18232; MS18233 contacts	RG178/U; RG196/U
601967-3	Turret TH163 [M22520/1-04] for MS27490; MS27655	0.2 - 4.0 (24-12)
601967-8	Turret TH199S [M22520/1-08] for MS3343; MS90460; MS90461 contacts	0.14 - 4.0 (26-12)
1-601967-6	Turret TH502 for Multimate TYPE II Size 16 Pin Contacts	0.03 - 2.5 (32-14)
1-601967-5	Turret TH501 for Multimate TYPE II Size 16 Socket Contact	0.03 - 2.5 (32-14)
601967-6	Turret TP45 [M22520/1-06] for OSI2814 type M size 16 & 22	0.14 - 1.5 (26-16)
1-601967-1	Turret TH128 for Type II contacts	2.5 - 4.0 (14-12)

AFM8

601966-1 AFM8 [M22520/2-01] Crimp Tool without Positioner
 2031845-1 WA22 (Pneumatic AFM8) without Positioner

Image representative of type only

Features:

- 4/8 indent Crimp to Military standard
- Ratchet mechanism ensures complete crimp cycle
- 8 Position Dial select Indent Depth control
- Many Positioners available
- Ergonomic non-slip handles



AFM8 - Positioner

Accurately positions Contacts in the Tool

Features:

Data plate shows compatible Contacts and settings

Use in:

601966-1 [AFM8] - Base Tool without Positioner
 2031845-1 [WA22] - Pneumatic version without Positioner

Image representative of type only



Part Number	Description	mm ² (AWG) or other
1-601966-0	Positioner K328	
2-601966-8	Positioner K370 for ARINC 404 COAXICON	RG316/U; 188/U RG179/U RG178/U; 196/U
601966-8	Positioner K267 [M22520/2-23] for ARINC 404 Contacts	0.12 - 0.4 (26-22)
601966-7	Positioner K370 [M22520/2-12] for ARINC COAXICON size 15 contacts	RG178; RG179; RG188; RG196; RG316
1-601966-6	Positioner K345 for ARINC COAXICON size 5 contacts	.141Semi rigid; RG58C; RG180B; RG188; RG223
2-601966-6	Positioner K397 for ARINC COAXICON size 7 contacts	RG188
1-601966-7	Positioner K344 for ARINC COAXICON size 7 contacts	RG58C; RG188
601966-5	Positioner K13-1 [M22520/2-08] for ARINC size 20 Contacts	0.2 (24)
601966-6	Positioner K42 [M22520/2-09] for ARINC size 22 Pin Contacts	0.4 - 0.3 (22-28)
966254-1	Positioner for Coaxicon MCX Straight Plugs	
1-601966-5	Positioner K287 [M22520/2-11] for M39029/1-100; 1-101; 2-105; 3-108	0.15 - 0.6 (26-20)
2-601966-0	Positioner K338 [M22520/2-13] for M39029/16&18 contacts	0.03 - 0.09 (32-28)
2-601966-2	Positioner K339 [M22520/2-16] for M39029/17 contacts	0.03 - 0.09 (32-28)
1-601966-1	Positioner K151 [M22520/2-04] for MS18232; MS18233; MS18265; MS18266 contacts	RG178/U; RG196/U
1-601966-4	Positioner K43 [M22520/2-10] for MS27490; MS27491; MS27492; MS27493; MS27494; MS27655 contacts	0.2 - 0.6 (24-20)
1-601966-3	Positioner K40 [M22520/2-07] for MS27490; MS27655 contacts	0.08 - 0.4 (28-22)
601966-3	Positioner K60S [M22520/2-03] for MS3343; MS90461 contacts	0.03 - 0.4 (32-22)
601966-4	Positioner K41 [M22520/2-06] for Size 22 Socket Contacts	0.4 - 0.3 (22-28)
601966-2	Positioner K1S [M22520/2-02] for TERMINAL-BLOCK contact.	0.6 - 0.15 (20-26)
1579003-1	Positioner for TRIAD-01	
1490038-1	Positioner K789 for Winchester 100-54020S; 100-54028S contacts	0.06 - 0.6 (30-20)

Tools for Screw-machined Contacts

Revised:

March 2011

FT8

608668-1 - Base Tool without Positioner

Features:

- 4/8 indent Crimp
- Ratchet mechanism ensures complete crimp cycle
- 8 Position Dial select Indent Depth control
- Ergonomic non-slip handles

Image representative of type only



Part Number	Description	mm ² (AWG) or other
608668-2	Positioner TP731 for AMPLIMITE Size 8 Use with Hand Tool 608668-1	1.0 - 1.5 (18-16)

M300 BT

608651-1 - Base Tool without Positioner

Features:

- 4/8 indent Crimp
- Ratchet mechanism ensures complete crimp cycle
- 8 Position Dial select Indent Depth control
- Ergonomic non-slip handles

Image representative of type only



Part Number	Description	mm ² (AWG) or other
608651-2	Positioner TP1151 for AMPLIMITE Size 8 Use with Hand Tool 608651-1	2.5 - 10.0 (14-8)
608651-3	Positioner SP858 for AMPLIMITE Size 8 Use in hand Tool 608651-2	6.0 - 10.0 (10-8)

M309

2031849-1 - Base Tool without Positioner

Features:

- 4/8 indent Crimp
- Ratchet mechanism ensures complete crimp cycle
- 8 Position Dial select Indent Depth control
- Ergonomic non-slip handles

Image representative of type only



M310

356114-1 - Base Tool without Positioner

Features:

- 4/8 indent Crimp
- Ratchet mechanism ensures complete crimp cycle
- 8 Position Dial select Indent Depth control
- Ergonomic non-slip handles

Image representative of type only



Part Number	Description	mm ² (AWG) or other
356120-1	Positioner TP1088 Use in Hand Tool 356114-1	
356336-1	Positioner TP944 use with Hand tool 356114-1	2.5 - 10.0 (14-8)
356119-1	Positioner TP1068 for Type XII contacts Use in Hand Tool 356114-1	10.0 (8)
356337-1	Positioner TP1013 for Universal MATE-N-Lok II High Current 2mm use with Hand tool 356114-1	2.5 - 6.0 (14-10)

M317

2031853-1 - Base Tool without Positioner

Features:

- 4/8 indent Crimp
- Ratchet mechanism ensures complete crimp cycle
- 8 Position Dial select Indent Depth control
- Ergonomic non-slip handles

Image representative of type only



Tools for Screw-machined Contacts

Revised: March 2011

MH860

2031850-1 - Base Tool without Positioner

Features:

- 4/8 indent Crimp to Military standard M22520/7-01
- Ratchet mechanism ensures complete crimp cycle
- 8 Position Dial select Indent Depth control
- Many Turrets available
- Ergonomic non-slip handles

Image representative of type only



Part Number	Description	mm ² (AWG) or other
2031848-1	Positioner 86-20 for M39029 Contacts Use with hand Tool 2031850-1	0.2 - 0.6 (24-20)

HX4

608650-1 - Base Tool without Positioner

Features:

- Crimp to Military standard M22520/5-01
- Ratchet mechanism ensures complete crimp cycle
- Ergonomic non-slip handles

Image representative of type only



Part Number	Description	mm ² (AWG) or other
2031852-1	Die-set Y197 - M22520/5-6	Hex .178 / .213" A/F
2031851-1	Die-set Y178 - M22520/5-6	Hex .429" A/F

ERGOCRIMP - Chrome

1-1105850-8 Base Tool without Die-set (pictured)

Note: This tool is not compatible with SDE Dies

Image representative of type only

Features:

- Chrome plated for greater corrosion resistance.
- Interchangeable Dies
- Virtually a straight action jaw closure
- Ratchet mechanism ensures complete crimp cycle
- Easy access ratchet release
- Handle pressure adjustment with locking device
- Ergonomic non-slip handles

The listed Dies can be used in the same options as regular ERGOCRIMP Dies



Part Number	Description	mm ² (AWG) or other
2-1105652-8	Die-set for HS S Contacts	10.0 & 16.0
539744-2	Die-set for HTS HDM	0.2 - 0.5
539668-2	Die-set for HTS HDM Contacts	0.2 - 1.5
1-1105652-8	Die-set for HTS HSS Contacts	6.0 & 25.0
1-1105851-8	Complete Tool for HTS: HE/HA; HND; HVT Contacts	0.14 - 4.0
1-1105852-8	Die-set for HTS: HE/HA; HND; HVT Contacts	0.14 - 4.0
2-1105870-8	Die-set for HTS: HSK; HSM; HSS Contacts	4.0 - 10.0
1-1105870-8	Die-set for HTS: HSM; HSK; HSS Contacts	0.75 - 2.5

Hydraulic Hand Tool 30 KN

1-1105653-8 Hand tool without Die-set

Features:

- Lightweight Tool with rotating head
- Pump action closure with low handle force
- Adjustable stroke
- Automatic release with audible "click"
- Manual override trigger release

Image representative of type only



Part Number	Description	mm ² (AWG) or other
5-1105653-8	Die-set for HF Contacts	25.0 (4)
6-1105653-8	Die-set for HF Contacts	35.0 (2)
8-1105653-8	Die-set for HF Contacts	70.0 (2/0)
7-1105653-8	Die-set for HF Contacts	50.0 (1/0)
3-1105653-8	Die-set for HS S & HF Contacts	10.0 (8)
4-1105653-8	Die-set for HS S & HF Contacts	16.0 (6)
2-1105653-8	Die-set for HTS: HSS; HF Contacts	6.0 (10)

Tools for Screw-machined Contacts

Revised:

March 2011

Hydraulic Hand Tool 60 KN

1110956-1 Hand tool without Die-set supplied in plastic carry case

Features:

Rotating head

Pump action closure with low handle force

Automatic release with audible "click"

Manual override trigger release

Image representative of type only



Part Number	Description	mm ² (AWG) or other
1110956-5	Die-set for HF Contacts	120.0 (4/0)
1110956-6	Die-set for HF Contacts	150.0mm ²
1110956-7	Tool-set comprising; 1110956-1 + 1110956-2 to -6 inclusive for HF contacts	50.0 - 150.0 (1/0-4/0)
1110956-2	Die-set for HF Contacts	50.0 (1/0)
1110956-3	Die-set for HF Contacts	70.0 (2/0)
1110956-4	Die-set for HF Contacts	95.0 (3/0)

Ampliset repair Kit

Ideal for Service and Repair

Features:

- 1-off Superchamp II hand tool
- A small quantity of 21 of the most common pre-insulated terminals and splices
- Packaged in a compact plastic wallet

For more detail please see information flyer 1308204

Image representative of type only



Part Number	Description	mm ² (AWG) or other
725972	Pre-insulated Terminals & Splices	0.5 - 6.6 (20-10)

Service Kit - SUPERCHAMP II

Ideal for Service and Repair

Features:

- Superchamp II hand tool
- A small quantity of the most common pre-insulated terminals and splices
- Packaged in a hard plastic snap-shut case

For more detail please see information flyer 1308204

Image representative of type only



Part Number	Description	mm ² (AWG) or other
725922	Installation, service and repair for Electrician's	0.5 - 6.6 (20-10)
725929	Service and repair for Automotive applications	0.5 - 6.6 (20-10)

Service Kit - CRIMPAC CG

Ideal for Service and Repair

Faster crimping than Service Kit PN 725922 as the CRIMPAC AG Hand Tool crimps both wire and insulation simultaneously

Image representative of type only

Features:

- CRIMPAC CG hand tool
- Twice the quantity of terminals and splices supplied in Service Kit PN 725922
- Packaged in a hard plastic snap-shut case

For more detail please see information flyer 1308204



Part Number	Description	mm ² (AWG) or other
725923	Installation, service and repair for Electrician's	0.5 - 6.6 (20-10)

Universal Service Tool Kit

Ideal for Service and Repair

Features:

Comprises:

Service Kit Tool 3-1579000-0

Interchangeable Die-sets for:

PIDG, PLASTIGRIP Green/Yellow

PIDG, PLASTIGRIP Red/Blue

FASTON; FASTIN-FASTON 0.5 - 6.0 (22-10)

SOLISTRAND Terminals & Splices 0.5 - 6.0 (22-10)

Wire End Ferrules 0.25 - 6.0 (24-10)

Image representative of type only



Part Number	Description
1-1579010-5	Universal Service Tool Kit

mm² (AWG) or other
see relevant Die

Starter Kit

Ideal for Service and Repair

Features:

A strong all purpose Carry Case

Termination Tool Kit

25 Jacks

Instruction Sheet

CD-Rom with videos showing step-by-step cable termination & printable instructions

Image representative of type only



Part Number	Description
2-1579010-7	110 SL Series Shielded Jacks
2-1579010-6	110 SL Series Unshielded Jacks
2-1579010-9	AMP TWIST Jacks
2-1579010-8	Cat5e SL Jacks

mm² (AWG) or other
0.2 (24) stranded
0.2-0.4 (24-22) solid
0.2 (24) stranded
0.2-0.4 (24-22) solid
0.2 (24) stranded
0.2-0.4 (24-22) solid
0.2 (24) stranded
0.2-0.4 (24-22) solid

Installers Kit

Ideal for Installation, Service and Repair

Features:

- A strong all purpose Carry Case
- SL110 Jack Termination Tool Kit
- Premium Impact Tool
- Cable Stripper
- 4-Pair Cable tester
- Palm Tool
- Wire Cutters
- Cross-head & Flat-bladed Screwdrivers
- Instruction Sheet
- CD-Rom with videos showing step-by-step cable termination & printable instructions

Image representative of type only



Part Number	Description
2-1579010-1	110 SL Jacks & AMP TWIST 6S SL

mm ² (AWG) or other
0.2 (24) stranded
0.2-0.4 (24-22) solid

Pistol Grip tool kit for 2mm FB + HM

1490375-1 for Shielded 2mm FB connectors

Features:

- Pistol Grip hand tool
- Module feed tracks 2 x 4 posn. & 2 x 5 posn.
- Bench clamp, cable support bar & brush
- Hex. Keys; 1.5, 2.5, 3 & 4mm
- Durable plastic carry case with foam insert
- All you need to apply 2mm FB connectors

Image representative of type only



Pistol Grip Kit for RV-100

Task specific Kits for RV-100 Connectors

Features:

- Kit Comprises:
- Pistol Grip Hand Tool
- Bench Clamp
- Service Tool
- Replacement contacts
- Durable plastic carry case with foam insert.

Image representative of type only



See relevant Instruction Sheet for exact list

Part Number	Description
528405-7	RV-100 23 Posn.
658164-3	RV-100 MULTIPLEXER 16 Posn. RV-100 32, 48, 64, 80, 96 Posn.; RV-100-4 32 Posn.

mm ² (AWG) or other
0.06 - 0.4 (30-22)
0.05 - 0.35 (30-22)

VS-3 Hand Tool Kit

Features:

- 1 Kit comprises:
 - Hand Tool
 - Crimp Height Gauge
 - Black Nylon Chord
 - Repair Tag
 - Durable Plastic Carry-case

-5 Kit is the same as the -1 Kit + Tool Holder 229755-1

-6 Kit is the same as the -1 Kit except:
the standard hand tool is replaced with 230971-5

Image representative of type only

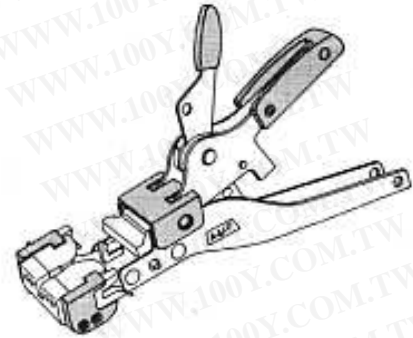

Part Number	Description	mm ² (AWG) or other
244271-1	PICABOND	[28-19]
244271-5	PICABOND (includes Tool Holder 229755-1)	[28-19]
244271-3	PICABOND Mini	(28-19)

VS-3 Hand Tool Holder

Features:

- Cable Clamp with 360° rotation
- Serrated Jaws
- Tool lock

Image representative of type only

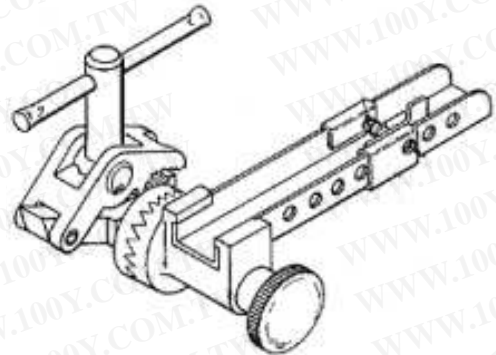

Part Number	Description	mm ² (AWG) or other
229755-1	VS-3 Hand Tool Holder	

10 Pair Splicing Kit

A range of specialist kits for 10 Pair AMP STACK applications

Features:

Quick and easy one action termination
 Splicing Head has many positioning options
 Applies AMP STACK 10 pair MkIV modules and compatible connectors:
 Straight Splicing, Pluggable or Half-tap
 Dry or Sealed

Image representative of type only



Part Number	Description	mm ² (AWG) or other
790112-1	GB restricted British Telecom special Comprises; Carry Case, Hand Tool, Splicing Head, Check Combe and Single Point Insertion Tool	0.4 - 0.9 (22-20)
790112-2	GB restricted to British Telecom Comprises; Carry Case, Hand Tool, Splicing Head, Check Combe, Single Point Insertion Tool and Electrical Tester	0.4 - 0.9 (22-20)
790112-3	GB restricted to British Telecom Comprises; Carry Case, Hand Tool, Splicing Head, Check Combe, Single Point Insertion Tool and 10 Pair Clamp Bar	0.4 - 0.9 (22-20)
790112-4	GB restricted to British Telecom Comprises; Carry Case, Hand Tool, Splicing Head, Check Combe, Single Point Insertion Tool, 10 Pair Clamp Bar and Electrical Tester	0.4 - 0.9 (22-20)
1-790112-1	Comprises; Carry Case, Hand Tool, Splicing Head, Check Combe and Single Point Insertion Tool	0.4 - 0.9 (22-20)
1-790112-2	Comprises; Carry Case, Hand Tool, Splicing Head, Check Combe, Single Point Insertion Tool and Electrical Tester	0.4 - 0.9 (22-20)
1-790112-3	Comprises; Carry Case, Hand Tool, Splicing Head, Check Combe, Single Point Insertion Tool and 10 Pair Clamp Bar	0.4 - 0.9 (22-20)
1-790112-4	Comprises; Carry Case, Hand Tool, Splicing Head, Check Combe, Single Point Insertion Tool, 10 Pair Clamp Bar and Electrical Tester	0.4 - 0.9 (22-20)
1-790112-5	Standard Commercial Kit Comprises; Carry Case, Hand Tool, Splicing Head, Check Combe, Single Point Insertion Tool, Electrical Tester, Instruction Sheet	0.4 - 0.9 (22-20)
790142-1	Universal Kit Comprises; Carry Case, Hand Tool, Single Point Insertion Tool, Splicing Head, Electrical Tester, Sparating Tool and Check Combe	0.4 - 0.9 (22-20)
1-790142-1	Universal Kit Comprises; Carry Case, Hand Tool, Single Point Insertion Tool, Splicing Head, Electrical Tester, Sparating Tool and Check Combe	0.4 - 0.9 (22-20)

25 Pair Splicing Kit

A range of specialist kits for 25 Pair AMP STACK applications

Features:

- Quick and easy one action termination
- Splicing Head has many positioning options
- Applies AMP STACK 25 pair Mk III modules and compatible connectors:
- Straight Splicing, Pluggable or Half-tap
- Dry or Sealed
- A two position latch feature allows for any combination of module to be terminated

Image representative of type only



Part Number	Description	mm ² (AWG) or other
790131-1	GB Special for British Telecom Comprises; Carry Case, Hand Tool, Splicing Head, T-Pedestal, Check Combe and Single Point Insertion Tool	0.32 - 0.8 (24-20)
790131-2	GB Special for British Telecom Comprises; Carry Case, Hand Tool, Splicing Head, T-Pedestal, Check Combe, Single Point Insertion Tool, Single Pair Tester and Single Point Separating Tool	0.32 - 0.8 (24-20)
790131-3	Standard Commercial Kit Comprises; Carry Case, Hand Tool, Single Point Insertion Tool, Splicing Head, Electrical Tester, T-Pedestal and Check Combe	0.32 - 0.8 (24-20)

Crimping Pliers

TELSPLICE

Features:

- Shut height stop prevents over-crimping
- Rounded nose won't snag on wires
- Built-in wire cutter

Image representative of type only



Part Number	Description	mm ² (AWG) or other
790162-1	all TELSPLICE products - sprung-open Jaws	0.4 - 0.9 (22-20)
231839-1	all TELSPLICE products - passive Jaws	0.4 - 0.9 (22-20)

Double Point Electrical Tester

790106-1 - A specifically designed probe acting as an interface between the applied product and test equipment and to prevent damage to the connector

Image representative of type only

Features:

- A plug-on test probe
- Can be used held in position or clipped in position



Single Point Insertion Tool

224290-1 Repair tool for use with AMP STACK1 0 & 25 Pair Modules

Image representative of type only

Features:

- Comfortable moulded handle
- Moulded-in metal insert for long life



Part Number	Description	mm ² (AWG) or other
224290-1	Not to be supplied to BritishTelecom	0.3 - 0.9 (24-20)
790172-1	Prefered by British Telecom over 224290-1	0.3 - 0.9 (24-20)

10 Pair Separator Tool

790104-1 - Designed to separate AMP STACK pluggable modules

Image representative of type only

Features:

- Robust pressed steel design
- One action separation



Check Combe, 10 pair

356073-1 - visual aid used in AMP STACK modular jointing applications to check wire colour positioning

Features:

Simple durable moulded design

Image representative of type only



Check Combe, 25 pair

224517-1 - visual aid used in AMP STACK modular jointing applications to check wire colour positioning

Features:

Simple durable moulded design

Image representative of type only



Single Point Separator Tool

790141-1 - Designed to separate AMP STACK 10 or 25 pair pluggable modules

Features:

Does the same job as 790104-1 but in a progressive way
Sprung open jaws aid separation

Image representative of type only



Splicing Head, 10 Pair with Pedestal Bar, 10 Pair

1-790114-1 - for AMP STACK Mk IV 10 Pair applications

Features:

- Snug fit product location
- Wire combs for wire guidance and separation
- Spring clamping to hold
- Compact pedestal bar mounting

Image representative of type only



Splicing Head, 10 Pair

1-790114-2 - for AMP STACK Mk IV 10 Pair applications

Features:

- Snug fit product location
- Wire combs for wire guidance and separation
- Spring clamping to hold

Image representative of type only



Splicing Head, 25 Pair

224636-1 - for AMP STACK Mk III 25 Pair applications

Features:

- Snug fit product location
- Wire combs for wire guidance and separation
- Spring clamping to hold

Image representative of type only



BT 3500 Battery-Hydraulic Hand Tool

- 2-2031400-1 EU mains plug
- 3-2031400-1 UK mains plug

Image representative of type only

Features:

- Highly portable - many options
- Over 250 crimps per charge
- Compact and lightweight Head
- Quick take-up terminal retention

The Tool Kit includes:

- Carry case with shoulder straps
- Li-ion Battery
- Battery Charger 220 v
- Re-set Tool



for SDE options, please see the SDE section

Part Number	Description	mm ² (AWG) or other
2031403-1	BT 3500 Bench-mount	
2031450-1	C Head for SDE Shoulder Dies	
2031460-1	Closed Head for SDE Pin & Shoulder Dies	
2031480-1	Certi-crimp II Head adapter	
2031489-1	Carry Case	
2063863-1	Padded belt	
2063864-1	4-Point Harness (for use with padded belt)	
2063870-2	Charger 220V 50 Hz - EMEA	
2063870-3	Charger 220V 50 Hz - UK	
2063874-2	AC Adapter 220v 50 Hz - EMEA	
2063874-3	AC Adapter 220v 50 Hz - UK	
2119483-1	DAHT Head Adapter	
2119810-1	C-Head SAHT Adapter	
2119840-1	HFFF Head Adapter	

Electric Terminator EU

539630-1 - Portable Bench-top Unit with foot switch (requires head / Adapter).
Ideal for low to medium production volumes.

Image representative of type only

Features:

Portable Bench-top Unit

- Mains powered unit - no air required (EU mains plug)
- Switchable 110v or 240v supply
- Cycle Counter
- Two stage crimp cycle option
- Includes Foot switch 1673664-1



Part Number	Description	mm ² (AWG) or other
169411	Adapter for CERTI-LOK Dies	
1213860-1	Adapter for CERTI-CRIMP II Heads	
1673663-2	Adapter for SDE Dies	
1901556-1	Adapter for C-Head SAHT Dies	
2-1579001-3	Mini CERTI-LOK Head for Wire End Ferrules	0.08 - 10.0 (28-8)

Micro Pneumatic

Ideal for low to medium production volumes.

Features:

- All pneumatic
- Wire range of 0.12 - 2.0 mm² [26-14]
- Weighing only 0.7 kg (1.5lb)
- 146.5 mm (5.75") long

The Basic system requires:

- A Power Unit
- A Tool Holder / Adapter
- A Head Assembly

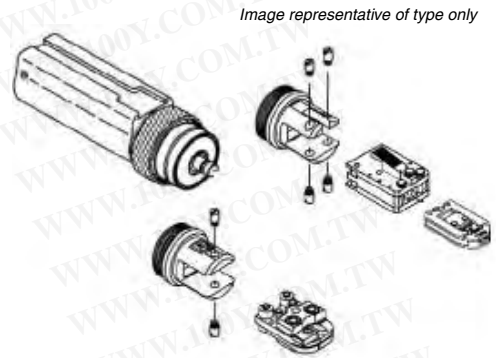

Image representative of type only

Micro Pneumatic Adapter

Adapter only

Features:

- Also required:
- Adapter Holder with Ratchet 356304-1
- or Adapter Holder without Ratchet 189928-1
- and
- Hand held power unit 1490567-1

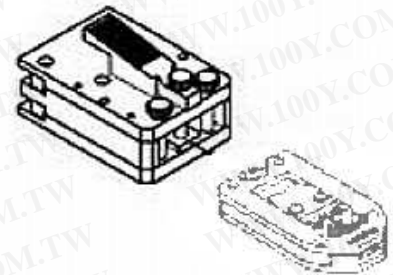

Image representative of type only

Part Number	Description	mm ² (AWG) or other
1583527-1	Adapter for CERTI-CRIMP II SAHT (pictured)	

Micro Pneumatic Crimping Head

Crimping Head only

Features:

- Also required:
- Small Tool Holder with Ratchet 1673611-1
- and
- Hand held power unit 1490567-1

The listed Heads can also be used in the 626 pneumatic system

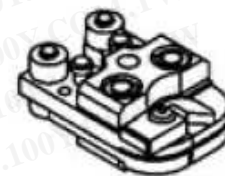

Image representative of type only

Part Number	Description	mm ² (AWG) or other
314270-3	PIDG Terminals & Splices; PLASTI-GRIP Terminals	0.4 - 1.5 (22-16)
314269-1	PIDG Terminals & Splices; PLASTI-GRIP terminals	1.5 - 2.5 (16-14)
314868-1	PLASTI-GRIP Butt Splice	0.4 - 1.5 (22-16)
314869-1	PLASTI-GRIP Butt Splice	1.5 - 2.5 (16-14)
314516-1	SOLISTRAND Terminals & Splices	0.4 - 1.5 (22-16)
314517-1	SOLISTRAND Terminals & Splices	1.5 - 2.5 (16-14)
314518-1	SOLISTRAND Terminals & Splices	2.5 - 4.0 (14-12)

626 Pneumatic

Ideal for low to medium production volumes.

Features:

All pneumatic
Wire range of 0.12 - 13.0 mm² [26-6]

The Basic system requires:

- A Power Unit
- A Tool Holder / Adapter
- A Head Assembly & Die-set (when applicable)

Image representative of type only

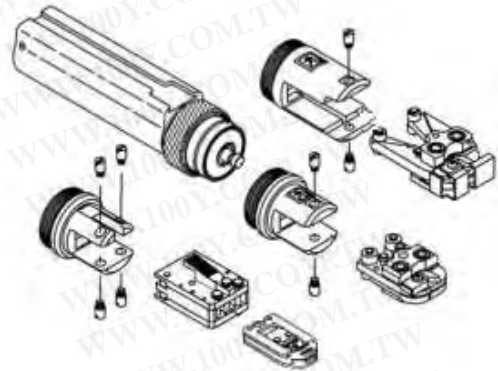

626 Pneumatic Adapter

Adapter only

Features:

Also required:
Adapter Holder with Ratchet 356304-1
or Adapter Holder without Ratchet 189928-1
and
Hand held power unit 189721-1
or Foot actuated Power Unit 189722-1

Image representative of type only

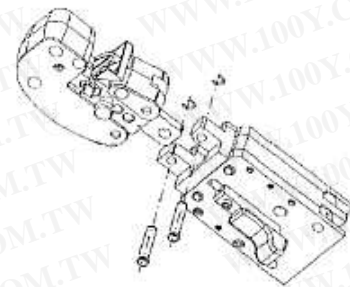

The above Adapter Holders also take Micro Pneumatic Adapters

Part Number	Description	mm ² (AWG) or other
525432-1	Adapter for Heavy Head Hand Tool	
1213563-1	Adapter for Double Action Hand Tool (pictured)	

626 Pneumatic Crimping Head (Small Tool Holder)

Crimping Head only

Features:

Also required:
Small Tool Holder with Ratchet 356303-1
or Tool Holder without Ratchet 189766-1
and
Hand held power unit 189721-1
or Foot actuated Power Unit 189722-1

Image representative of type only

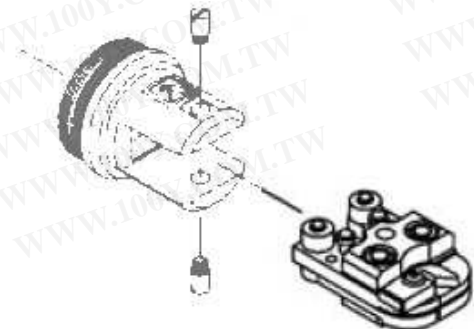

Part Number	Description	mm ² (AWG) or other
217205-1	Closed End Splice	0.4 - 1.5 (22-16)
354422-1	Closed End Splice	0.4 - 2.5 (22-14)
354422-2	Closed End Splice	0.4 - 6.0 (22-10)
314537-1	PIDG, PLASTI-GRIP Terminals & Splices	0.15 - 0.4 (26-22)
189989-1	Crimping Head for SOLISTRAND Terminals & Splices	0.4 - 6.0 (22-10)

626 Pneumatic Crimping Head (Large Tool Holder)

Crimping Head only

Features:

Also required:

Large Tool Holder with Ratchet 356302-1
or Tool Holder without Ratchet 189767-1
and

Hand held power unit 189721-1 (-2 with Booster]
or Foot actuated Power Unit 189722-1 (-2 with Booster]

Image representative of type only

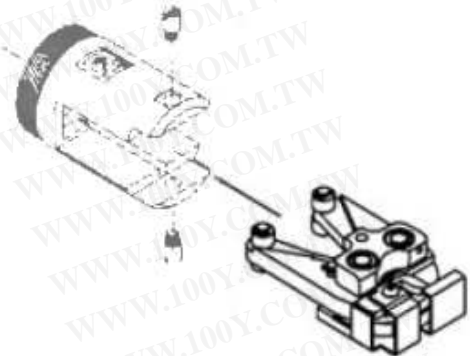

Part Number	Description	mm ² (AWG) or other
679304-1	Head Only for SDE Dies	4.0 - 6.0 (12-10)
189896-1	SOLISTRAND Terminals	1.0 - 10.0 (18-8)
189466-1	Closed End Splice	1.0 - 6.0 (18-10)
189447-1	COPALUM Terminals and Splices	1.5 - 2.5 (16-14)
1320369-1	COPALUM Terminals and Splices - *requires (-2) Power Units!	10.0 (8)
189444-1	COPALUM Terminals and Splices	4.0 - 6.0 (12-10)
679300-1	PIDG Terminals & Splices; PLASTI-GRIP Terminals	4.0 - 6.0 (12-10)
679301-1	Crimping Head for SOLISTRAND Terminals & Splices	0.4 - 6.0 (22-10)
1338757-1	SOLISTRAND Terminals & Splices	10.0 (8)
1338758-1	SOLISTRAND Terminals & Splices	6.0 (10)
217206-1	STRATO-THERM SOLISTRAND High Temp & Heat Resistant Terminals & Splices	0.4 - 6.0 (22-10)
904395-1	TERMINYL Terminals & Splices; (PLASTI-GRIP where no insulation crimp is required)	10.0 (8)

Bench Press AT-SC

528050-1 Bench Press AT-SC including SDE Die-set adapter

Ideally suited to:

- Insulated terminals up to 6 mm²
- Copper tube terminals up to 16 mm²
- Wire End Ferrules up to 50 mm²

Image representative of type only

Features:

NO GUARDING NECESSARY!

The machine will not operate when the jaw opening is greater than 6mm.

Variable pre-hold pressure.

Double Foot Pedal Actuation:

First pedal opens the jaws for terminal placement, releasing the pedal closes the head with pre-hold pressure only.

Second pedal activates the crimp cycle, pressing the first pedal again allows the crimped terminal to be removed.



Part Number	Description	mm ² (AWG) or other
1-528051-2	Die Holder for PEZ 100 Dies	
1-528051-4	Die Holder for WDT Dies	
1-528051-6	Die Holder for ERGOCRIMP Dies	
1-528051-8	Die Holder for C-Head SAHT Dies	

勝特力材料 886-3-5753170
 勝特力电子(上海) 86-21-34970699
 勝特力电子(深圳) 86-755-83298787
[Http://www.100y.com.tw](http://www.100y.com.tw)