

End clamp - CLIPFIX 35 - 3022218

Please be informed that the data shown in this PDF Document is generated from our Online Catalog. Please find the complete data in the user's documentation. Our General Terms of Use for Downloads are valid (<http://phoenixcontact.com/download>)



Quick mounting end clamp for NS 35/7,5 DIN rail or NS 35/15 DIN rail, with marking option, width: 9.5 mm, color: gray

Product Features

- Phoenix Contact has engineered its CLIPFIX end brackets to maintain a secure grip on the various DIN rail systems
- Design width of just 9.5 mm
- Large-surface labeling



Key Commercial Data

Packing unit	1 pc
Minimum order quantity	50 pc
GTIN	 4 017918 156541
Weight per Piece (excluding packing)	6.4 g
Custom tariff number	85389099
Country of origin	Poland

Technical data

Dimensions

Length (b)	55.6 mm
Width (a)	9.5 mm

General

Color	gray
Flammability rating according to UL 94	V2
Material	PA

Standards and Regulations

End clamp - CLIPFIX 35 - 3022218

Technical data

Standards and Regulations

Flammability rating according to UL 94	V2
--	----

Classifications

eCl@ss

eCl@ss 4.0	27141199
eCl@ss 4.1	27141199
eCl@ss 5.0	27141135
eCl@ss 5.1	27141135
eCl@ss 6.0	27141135
eCl@ss 7.0	27141135
eCl@ss 8.0	27141135
eCl@ss 9.0	27141135

ETIM

ETIM 2.0	EC000761
ETIM 3.0	EC001041
ETIM 4.0	EC001041
ETIM 5.0	EC001041

UNSPSC

UNSPSC 6.01	30212109
UNSPSC 7.0901	39121708
UNSPSC 11	39121708
UNSPSC 12.01	39121708
UNSPSC 13.2	39121708

Accessories

Accessories

DIN rail

DIN rail perforated - NS 35/ 7,5 PERF 2000MM - 0801733



DIN rail, material: steel galvanized and passivated with a thick layer, perforated, height 7.5 mm, width 35 mm, length: 2000 mm

End clamp - CLIPFIX 35 - 3022218

Accessories

DIN rail, unperforated - NS 35/ 7,5 UNPERF 2000MM - 0801681



DIN rail, material: Steel, unperforated, height 7.5 mm, width 35 mm, length: 2 m

DIN rail perforated - NS 35/ 7,5 WH PERF 2000MM - 1204119



DIN rail 35 mm (NS 35)

DIN rail - NS 35/ 7,5 WH UNPERF 2000MM - 1204122



DIN rail 35 mm (NS 35)

DIN rail, unperforated - NS 35/ 7,5 AL UNPERF 2000MM - 0801704



DIN rail, unperforated, Width: 35 mm, Height: 7.5 mm, Length: 2000 mm, Color: silver

DIN rail perforated - NS 35/ 7,5 ZN PERF 2000MM - 1206421



DIN rail, material: Galvanized, perforated, height 7.5 mm, width 35 mm, length: 2 m

End clamp - CLIPFIX 35 - 3022218

Accessories

DIN rail, unperforated - NS 35/ 7,5 ZN UNPERF 2000MM - 1206434



DIN rail, material: Galvanized, unperforated, height 7.5 mm, width 35 mm, length: 2 m

DIN rail, unperforated - NS 35/ 7,5 CU UNPERF 2000MM - 0801762



DIN rail, material: Copper, unperforated, height 7.5 mm, width 35 mm, length: 2 m

End cap - NS 35/ 7,5 CAP - 1206560



DIN rail end piece, for DIN rail NS 35/7.5

DIN rail perforated - NS 35/15 PERF 2000MM - 1201730



DIN rail, material: steel galvanized and passivated with a thick layer, perforated, height 15 mm, width 35 mm, length: 2000 mm

DIN rail, unperforated - NS 35/15 UNPERF 2000MM - 1201714



DIN rail, material: Steel, unperforated, height 15 mm, width 35 mm, length: 2 m

End clamp - CLIPFIX 35 - 3022218

Accessories

DIN rail perforated - NS 35/15 WH PERF 2000MM - 0806602



DIN rail 35 mm (NS 35)

DIN rail - NS 35/15 WH UNPERF 2000MM - 1204135



DIN rail 35 mm (NS 35)

DIN rail, unperforated - NS 35/15 AL UNPERF 2000MM - 1201756



DIN rail, deep drawn, high profile, unperforated, 1.5 mm thick, material: aluminum, height 15 mm, width 35 mm, length 2000 mm

DIN rail perforated - NS 35/15 ZN PERF 2000MM - 1206599



DIN rail, material: Galvanized, perforated, height 15 mm, width 35 mm, length: 2 m

DIN rail, unperforated - NS 35/15 ZN UNPERF 2000MM - 1206586



DIN rail, material: Galvanized, unperforated, height 15 mm, width 35 mm, length: 2 m

End clamp - CLIPFIX 35 - 3022218

Accessories

DIN rail, unperforated - NS 35/15 CU UNPERF 2000MM - 1201895



DIN rail, material: Copper, unperforated, 1.5 mm thick, height 15 mm, width 35 mm, length: 2 m

End cap - NS 35/15 CAP - 1206573



DIN rail end piece, for DIN rail NS 35/15

DIN rail, unperforated - NS 35/15-2,3 UNPERF 2000MM - 1201798



DIN rail, material: Steel, unperforated, 2.3 mm thick, height 15 mm, width 35 mm, length: 2 m

Labeled terminal marker

Zack marker strip - ZB 8 CUS - 0825011



Zack marker strip, can be ordered: Strip, white, labeled according to customer specifications, Mounting type: Snap into tall marker groove, for terminal block width: 8.2 mm, Lettering field: 10.5 x 8.15 mm

Marker for terminal blocks - UC-TM 8 CUS - 0824597



Marker for terminal blocks, can be ordered: by sheet, white, labeled according to customer specifications, Mounting type: Snap into tall marker groove, for terminal block width: 8.2 mm, Lettering field: 7.6 x 10.5 mm

End clamp - CLIPFIX 35 - 3022218

Accessories

Marker for terminal blocks - UCT-TM 8 CUS - 0829616



Marker for terminal blocks, can be ordered: by sheet, white, labeled according to customer specifications, Mounting type: Snap into tall marker groove, for terminal block width: 8.2 mm, Lettering field: 7.6 x 10.5 mm

Zack marker strip - ZB 8,LGS:FORTL.ZAHLEN - 1052015



Zack marker strip, Strip, white, labeled, can be labeled with: Plotter, Printed horizontally: Consecutive numbers 1 - 10, 11 - 20, etc. up to 491 - 500, Mounting type: Snap into tall marker groove, for terminal block width: 8.2 mm, Lettering field: 10.5 x 8.15 mm

Zack marker strip - ZB 8,QR:FORTL.ZAHLEN - 1052028



Zack marker strip, Strip, white, labeled, can be labeled with: Plotter, Printed vertically: Consecutive numbers 1 - 10, 11 - 20, etc. up to 91 - 100, Mounting type: Snap into tall marker groove, for terminal block width: 8.2 mm, Lettering field: 10.5 x 8.15 mm

Marker for terminal blocks - ZB 8,LGS:L1-N,PE - 1052413



Marker for terminal blocks, Strip, white, labeled, can be labeled with: Plotter, Horizontal: L1, L2, L3, N, PE, L1, L2, L3, N, PE, Mounting type: Snap into tall marker groove, for terminal block width: 8.2 mm, Lettering field: 10.5 x 8.15 mm

Marker carriers

Terminal strip marker carrier - KLM 2 - 0807575



Terminal strip marker carrier, gray, unlabeled, Mounting type: Plug in, Lettering field: 20 mm x 8 mm

End clamp - CLIPFIX 35 - 3022218

Accessories

Terminal marking

Marker card - SBS 8:UNBEDRUCKT - 1007235



Marker card, Card, white, unlabeled, can be labeled with: Plotter, Mounting type: Snap into tall marker groove, Snap into flat marker groove, for terminal block width: 8.2 mm, Lettering field: 6 x 8.1 mm

Zack marker strip - ZB 8:UNBEDRUCKT - 1052002



Zack marker strip, Strip, white, unlabeled, can be labeled with: Plotter, Mounting type: Snap into tall marker groove, for terminal block width: 8.2 mm, Lettering field: 10.5 x 8.15 mm

Marker for terminal blocks - UC-TM 8 - 0818072



Marker for terminal blocks, Sheet, white, unlabeled, can be labeled with: BLUEMARK CLED, BLUEMARK LED, Plotter, Mounting type: Snap into tall marker groove, for terminal block width: 8.2 mm, Lettering field: 7.6 x 10.5 mm

Marker for terminal blocks - UCT-TM 8 - 0828740



Marker for terminal blocks, Sheet, white, unlabeled, can be labeled with: THERMOMARK CARD, BLUEMARK CLED, BLUEMARK LED, TOPMARK LASER, Mounting type: Snap into tall marker groove, for terminal block width: 8.2 mm, Lettering field: 7.6 x 10.5 mm

Drawings

End clamp - CLIPFIX 35 - 3022218

Dimensional drawing

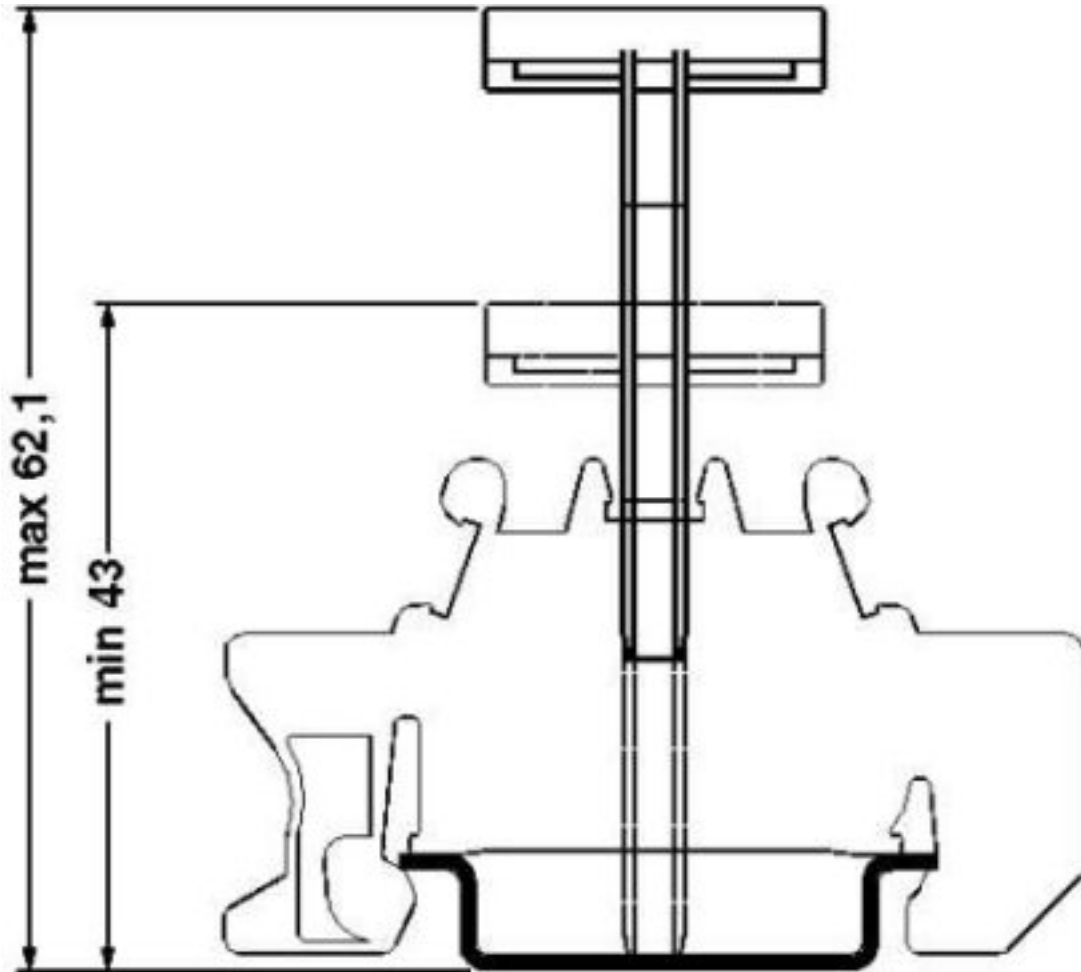

End clamp - CLIPFIX 35 - 3022218

Dimensional drawing

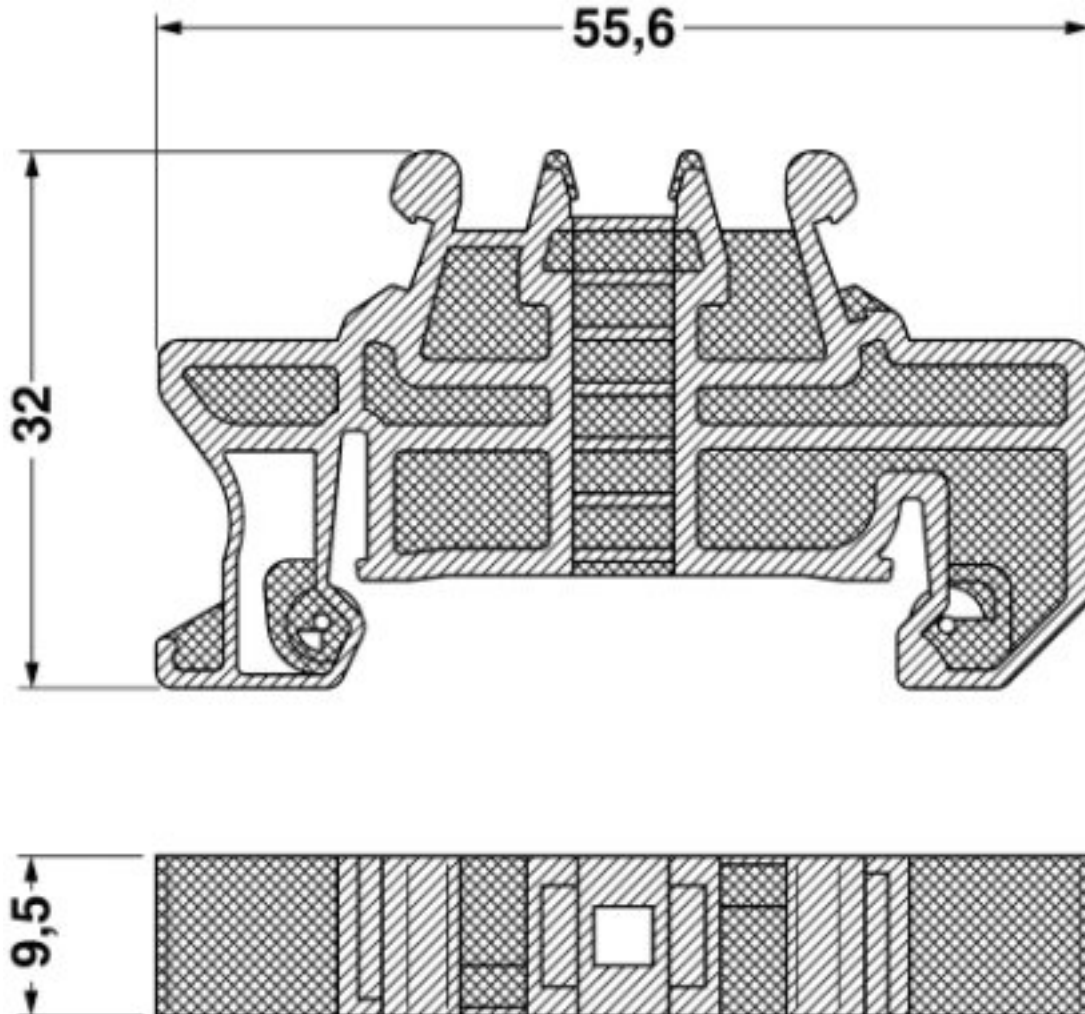

Mouser Electronics

Authorized Distributor

Click to View Pricing, Inventory, Delivery & Lifecycle Information:

[Phoenix Contact:](#)

[3022218](#)