

勝特力電材超市-龍山店 886-3-5773766
 勝特力電材超市-光復店 886-3-5729570
 勝特力電子(上海) 86-21-34970699
 勝特力電子(深圳) 86-755-83298787
<http://www.100y.com.tw>

REVISIONS					
REV	ECO	DESCRIPTION	DATE	BY	APPR
A3	-	RELEASE NEW DWG FORMAT	21OCT13	DRP	-
A4	-	REVISED PLATING INFO	16/JUN/16	JAH	-
A5	C1070S	UPDATE DRAWING	21/JUN/19	ROOKIE	TOMMY
B1	C1298S	UPDATE PLATING	14/SEP/20	SULLEN	TOMMY

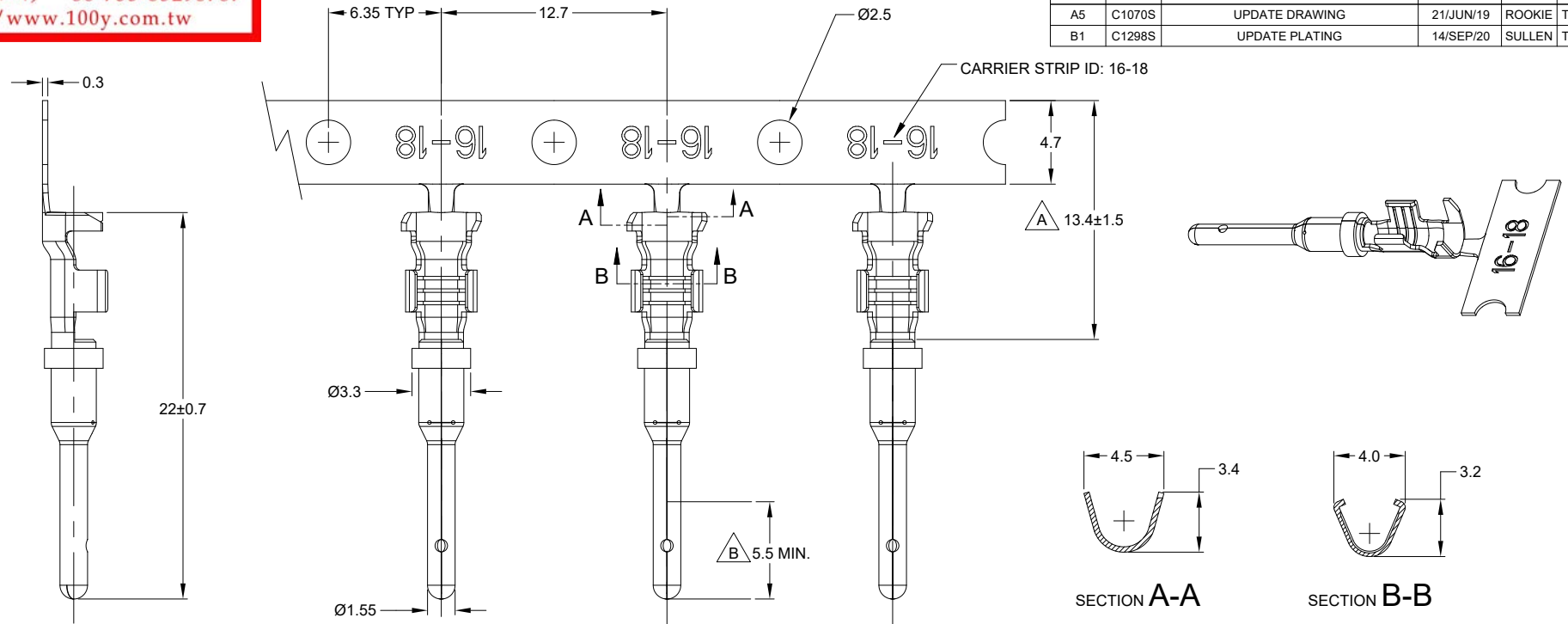

NOTES: UNLESS OTHERWISE SPECIFIED

- MATERIAL: COPPER ALLOY
- PLATING: SEE PART NUMBER CHART
- CONTACT SIZE: 16
- SPECIFICATIONS:
 - CURRENT RATING: 13 AMPS
 - CONTACT MILLIVOLT DROP: 100 MILLIVOLT DROP @ 13 AMP TEST CURRENT.
 - RoHS COMPLIANT
- RECOMMENDED WIRE RANGE: 16 - 18 AWG (1.5 - 0.75mm²)
 CUSTOMER OPTIONAL WIRE RANGE: 14 AWG (2.0mm²)
 RECOMMENDED INSUL O.D: 1.91 - 3.55MM (0.075 - 0.140INCH)
- PACKAGE: 4000 PCS/REEL
- AVAILABLE APPLICATORS: MFX-3953-K OR MFX-3953-G
- ALL DIMENSIONS ARE FOR REFERENCE USE ONLY

PART NUMBER CHART		
PLATING	PART NUMBER	PLATING DESCRIPTION
NICKEL	AT60-16-0122	SELECTIVE TIN OVER NICKEL OVERALL IN Δ ZONE
GOLD	AT60-16-0144	SELECTIVE GOLD FLASH OVER NICKEL OVERALL IN ∇ ZONE OR ENTIRE CONTACT
TIN	AT60-16-0177	TIN OVER NICKEL OVERALL

SEE PART NUMBER CHART		REF: 1060-16-0144, 1060-16-0122, 1060-16-0177	
QUANTITY	PART NUMBER	DESCRIPTION	ITEM
<p>MATERIALS LIST</p> <p>Amphenol</p> <p>Sine Systems - www.amphenol-sine.com 44724 Morley Drive Clinton Township, MI 48036</p> <p>CONTACT, PIN, STAMPED, SIZE 16, 16-18 AWG, A SERIES</p>			
<p>UNLESS OTHERWISE SPECIFIED</p> <p>1) All dimensions are in metric (mm).</p> <p>2) Tolerances are as follows:</p> <p>1 PL DEC ±0.30 Fractions ±1/64 2 PL DEC ±0.15 3 PL DEC ±0.08 Angles ±1°</p> <p>3) Note reference = Δ</p>		<p>SIGNATURES DATE</p> <p>DRAWN: SULLENZHANG 14/SEP/20</p> <p>CHECKED: ORIONLI 15/SEP/20</p> <p>ENGINEER:</p> <p>APPROVAL: TOMMYXIE 18/SEP/20</p> <p>CUSTOMER:</p>	
<p>MATERIAL SPECIFICATIONS:</p> <p>PROCESS SPECIFICATIONS:</p> <p>NEXT ASSY:</p>		<p>THIS DRAWING IS SUPPLIED FOR INFORMATION ONLY. DESIGN FEATURES, SPECIFICATIONS AND PERFORMANCE DATA SHOWN HEREON ARE THE PROPERTY OF THE AMPHENOL CORPORATION. NO RIGHTS OF REPRODUCTION ARE IMPLIED. ALL DIMENSIONS ARE SUBJECT TO NORMAL MANUFACTURING VARIATIONS.</p>	
<p>SIZE TYPE DWG NO.</p> <p>B C- AT60-16-01XX</p>		<p>REVISION</p> <p>B1</p>	
<p>SCALE: NONE</p>		<p>SHEET 1 OF 1</p>	

TITLE: PIN, STAMPED, SIZE 16, 16-18 AWG, A SERIES
 DWG NO: AT60-16-01XX
 REV: B1
 SH: 1
 OF: 1