

勝特力電材超市-龍山店 886-3-5773766  
 勝特力電材超市-光復店 886-3-5729570  
 勝特力電子(上海) 86-21-34970699  
 勝特力電子(深圳) 86-755-83298787  
<http://www.100y.com.tw>

REVISIONS					
REV	ECO	DESCRIPTION	DATE	BY	APPR
A1	-	RELEASE NUMBER	26OCT19	BROOK	TOMMY

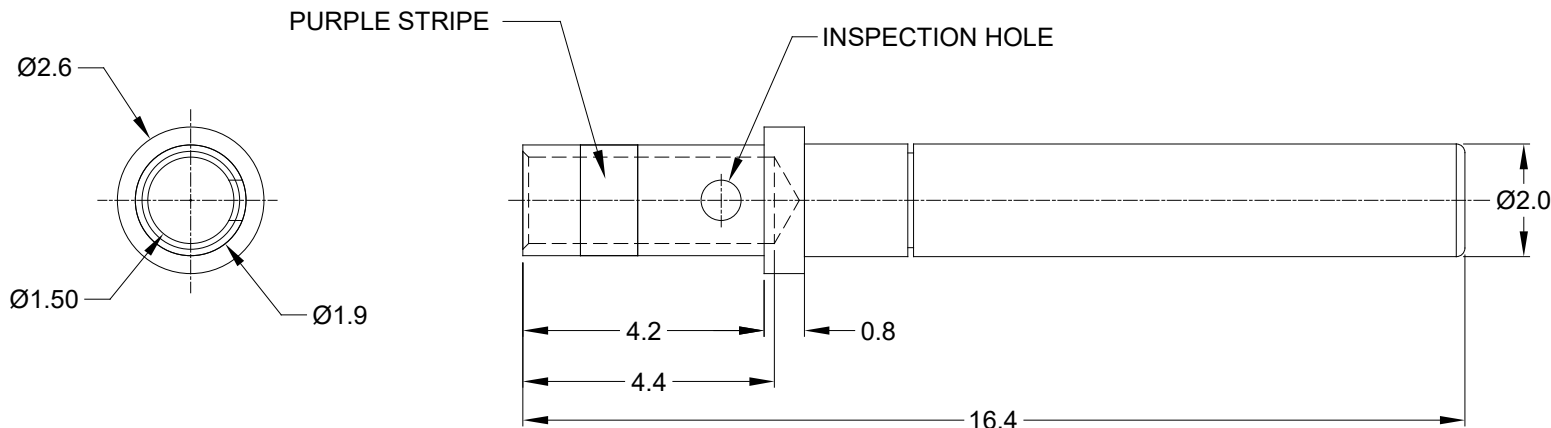

NOTES: UNLESS OTHERWISE SPECIFIED

- MATERIAL: COPPER ALLOY
- PLATING: SEE PART NUMBER CHART
- CONTACT SIZE: 20
- SPECIFICATIONS:
  - CURRENT RATING: 7.5 AMPS
  - CONTACT MILLIVOLT DROP: 60 MILLIVOLT DROP @ 7.5 AMP TEST CURRENT.
  - RoHS COMPLIANT
- RECOMMENDED WIRE RANGE: 18-16 AWG [0.75~1.0mm<sup>2</sup>]
- AVAILABLE HAND CRIMPER: CA-5D12
- ALL DIMENSIONS ARE FOR REFERENCE USE ONLY

PART NUMBER CHART	
PLATING	PART NUMBER
GOLD	AT62-005-2031
NICKEL	AT62-005-20141

SEE PART NUMBER CHART		0462-005-2031, 0462-005-20141	
PART NUMBER		DESCRIPTION	
QUANTITY	MATERIALS LIST		
UNLESS OTHERWISE SPECIFIED 1) All dimensions are in metric(mm). 2) Tolerances are as follows: 1 PL DEC ±0.30    Fractions ±1/64 2 PL DEC ±0.15    Angles ±1° 3 PL DEC ±0.08 3) Note reference = $\triangle$ X		SIGNATURES	DATE
MATERIAL SPECIFICATIONS:		DRAWN: BROOK.DING	26OCT19
PROCESS SPECIFICATIONS:		CHECKED: ORION.LI	26OCT19
NEXT ASSY:		ENGINEER:	
		APPROVAL: TOMMY	26OCT19
		CUSTOMER:	
		THIS DRAWING IS SUPPLIED FOR INFORMATION ONLY. DESIGN FEATURES, SPECIFICATIONS AND PERFORMANCE DATA SHOWN HEREON ARE THE PROPERTY OF THE AMPHENOL CORPORATION. NO RIGHTS OF REPRODUCTION ARE IMPLIED. ALL DIMENSIONS ARE SUBJECT TO NORMAL MANUFACTURING VARIATIONS.	
		<div style="text-align: center;"> <h1>Amphenol</h1> <p>Sine Systems - <a href="http://www.amphenol-sine.com">www.amphenol-sine.com</a>                      44724 Morley Drive                      Clinton Township, MI 48036</p> </div>	
		CONTACT, SOCKET, SOLID, SIZE 20, 16-18 AWG, A SERIES	
SIZE	TYPE	DWG NO:	REVISION
A	C-	AT62-005-20XXX	A1
SCALE: NONE		SHEET 1 OF 1	