

REVISIONS					
REV	ECO	DESCRIPTION	DATE	BY	APPR
A3	-	RELEASE NEW DWG FORMAT	21/OCT/13	DRP	-
A4	C1070S	UPDATE DRAWING	28/JUN/19	JOE	TOMMY
A5	C1298S	UPDATE PLATING	14/SEP/20	SULLEN	TOMMY

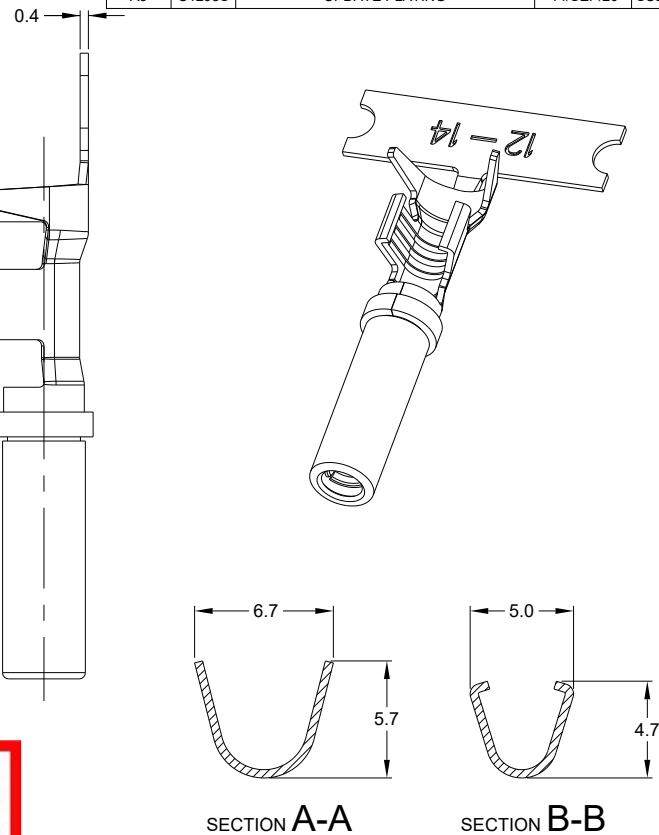
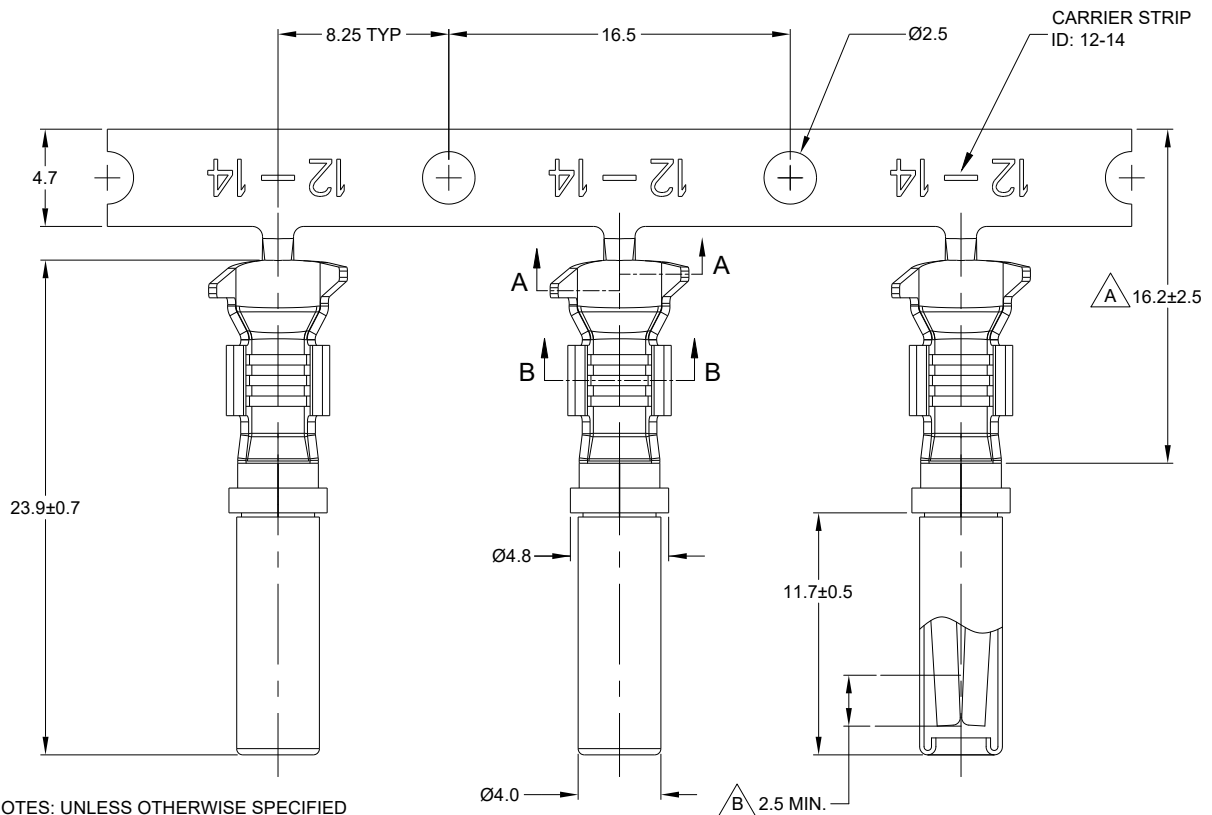

NOTES: UNLESS OTHERWISE SPECIFIED

- MATERIAL: COPPER ALLOY
- PLATING: SEE PART NUMBER CHART
- CONTACT SIZE: 12
- SPECIFICATIONS:
  - CURRENT RATING: 25 AMPS
  - CONTACT MILLIVOLT DROP: 100 MILLIVOLT DROP @ 25 AMP TEST CURRENT.
  - ROHS COMPLIANT
- RECOMMENDED WIRE RANGE: 12 - 14 AWG (4.0 - 2.0MM<sup>2</sup>)  
RECOMMENDED INSUL O.D.: 2.87 - 4.47MM (0.113 - 0.176INCH)
- PACKAGE: 2000 PCS/REEL
- AVAILABLE APPLICATORS: MFX-3973-K OR MFX-3973-G
- ALL DIMENSIONS ARE FOR REFERENCE USE ONLY

勝特力電材超市-龍山店 886-3-5773766  
 勝特力電材超市-光復店 886-3-5729570  
 勝特力電子(上海) 86-21-34970699  
 勝特力電子(深圳) 86-755-83298787  
<http://www.100y.com.tw>

PART NUMBER CHART		
PLATING	PART NUMBER	PLATING DESCRIPTION
NICKEL	AT62-12-0166	SELECTIVE TIN OVER NICKEL OVERALL IN $\Delta$ ZONE
GOLD	AT62-12-0144	SELECTIVE GOLD FLASH OVER NICKEL OVERALL IN $\Delta$ ZONE OR ENTIRE CONTACT
TIN	AT62-12-0177	TIN OVER NICKEL OVERALL

SEE PART NUMBER CHART		REF: 1062-12-0144, 1062-12-0166	
PART NUMBER		DESCRIPTION	
QUANTITY		MATERIALS LIST	
UNLESS OTHERWISE SPECIFIED 1) All dimensions are in metric(mm). 2) Tolerances are as follows: 1 PL DEC ±0.30 2 PL DEC ±0.15 3 PL DEC ±0.08 Fractions ±1/64 Angles ±1°		SIGNATURES DATE DRAWN: SULLENZhang 14/SEP/20 CHECKED: ORIONLI 15/SEP/20 ENGINEER: APPROVAL: TOMMYXIE 18/SEP/20 CUSTOMER:	
MATERIAL SPECIFICATIONS:		<b>Amphenol</b> Sine Systems - www.amphenol-sine.com 44724 Morley Drive Clinton Township, MI 48036	
PROCESS SPECIFICATIONS:		CONTACT, SOCKET, STAMPED, SIZE 12, 12-14 AWG, A SERIES THIS DRAWING IS SUPPLIED FOR INFORMATION ONLY. DESIGN FEATURES, SPECIFICATIONS AND PERFORMANCE DATA SHOWN HEREON ARE THE PROPERTY OF THE AMPHENOL CORPORATION. NO RIGHTS OF REPRODUCTION ARE IMPLIED. ALL DIMENSIONS ARE SUBJECT TO NORMAL MANUFACTURING VARIATIONS.	
NEXT ASSY:		SIZE TYPE DWG NO. <b>B C-</b> <b>AT62-12-01XX</b>	REVISION <b>A5</b>
		SCALE: NONE	SHEET 1 OF 1

TITLE: CONTACT, STAMPED, SIZE 12, 12-14 AWG, A SERIES  
 DWG NO: AT62-12-01XX  
 REV: A5  
 SH: 1  
 OF: 1