

REVISIONS					
REV	ECO	DESCRIPTION	DATE	BY	APPR
A3	-	RELEASE NEW DWG FORMAT	21/OCT/13	DRP	-
A4	C1070S	UPDATE DRAWING	28/JUN/19	JOE	TOMMY
A5	C1298S	UPDATE PLATING	14/SEP/20	SULLEN	TOMMY
A6	-	UPDATE THE WIRE GAGE	09/OCT/23	LUCAS	TOMMY

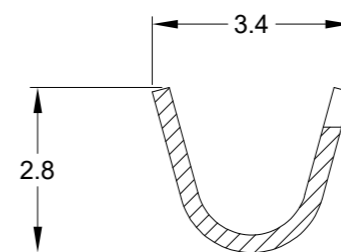

SECTION A-A  
SCALE - 2:1

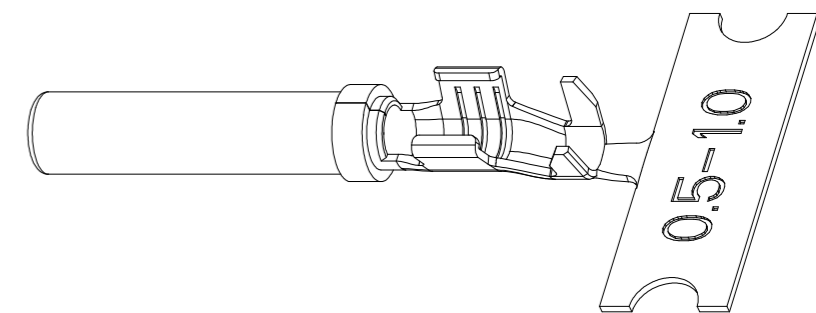
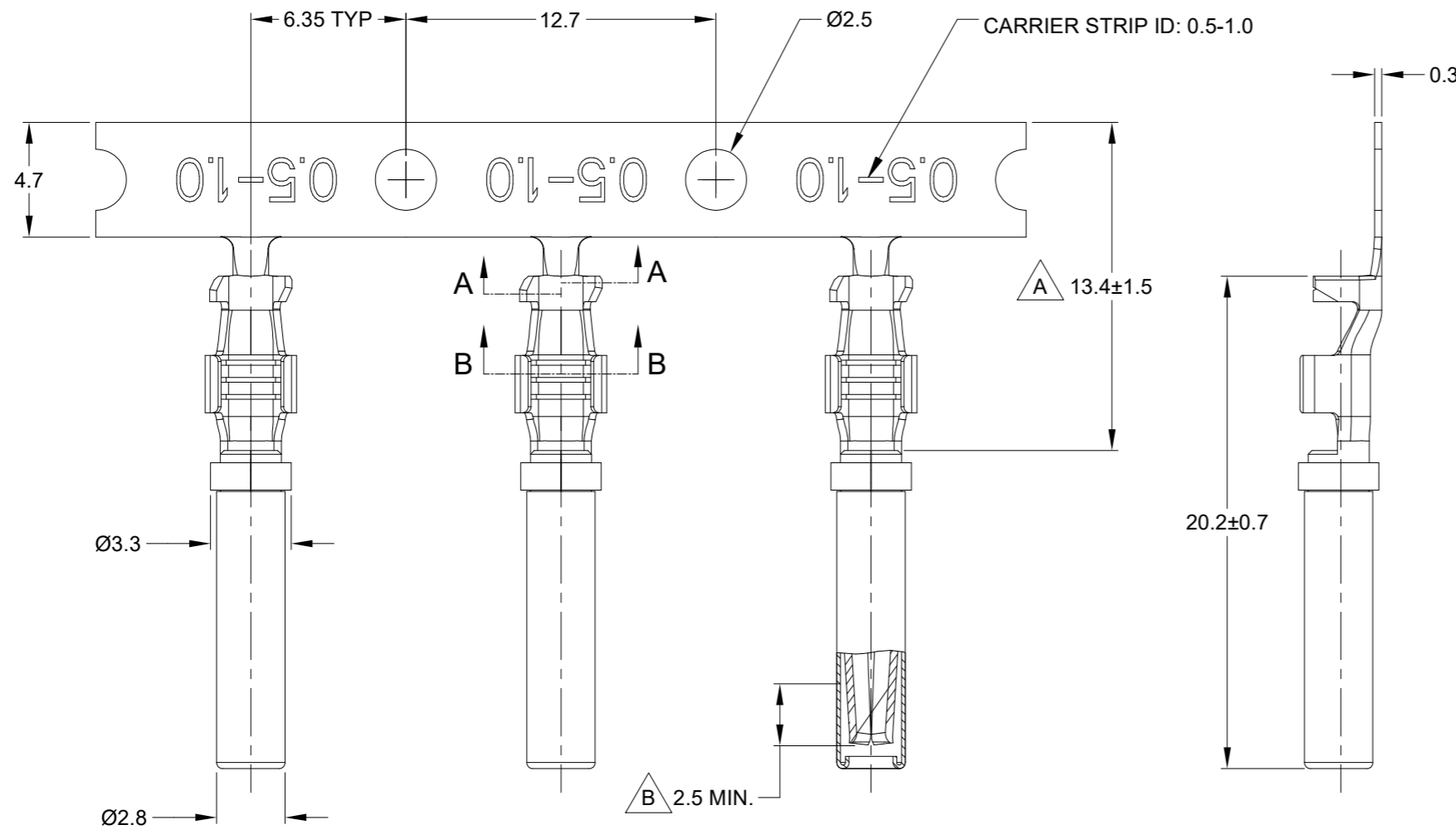
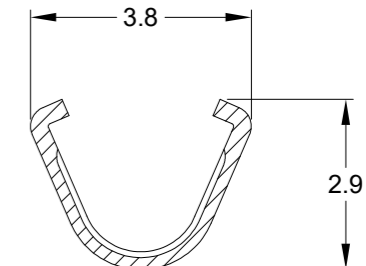

SECTION B-B  
SCALE - 2:1

NOTES: UNLESS OTHERWISE SPECIFIED

- MATERIAL: COPPER ALLOY
- PLATING: SEE PART NUMBER CHART
- CONTACT SIZE: 16
- SPECIFICATIONS:
  - CURRENT RATING: 13 AMPS
  - CONTACT MILLIVOLT DROP: 100 MILLIVOLT DROP @ 13 AMP TEST CURRENT.
  - RoHS COMPLIANT
- RECOMMENDED WIRE RANGE: 16 - 20 AWG (1.0 - 0.5mm<sup>2</sup>)  
RECOMMENDED INSUL O.D: 1.40 - 2.54MM (0.055 - 0.1 INCH)
- PACKAGE: 4000 PCS/REEL
- AVAILABLE APPLICATORS: MFX-3950-K OR MFX-3950-G
- ALL DIMENSIONS ARE FOR REFERENCE USE ONLY

勝特力電材超市-龍山店 886-3-5773766  
 勝特力電材超市-光復店 886-3-5729570  
 勝特力电子(上海) 86-21-34970699  
 勝特力电子(深圳) 86-755-83298787  
<http://www.100y.com.tw>

PART NUMBER CHART		
PLATING	PART NUMBER	PLATING DESCRIPTION
NICKEL	AT62-16-0622	SELECTIVE TIN OVER NICKEL OVERALL IN $\Delta$ ZONE
GOLD	AT62-16-0644	SELECTIVE GOLD FLASH OVER NICKEL OVERALL IN $\Delta$ ZONE OR ENTIRE CONTACT
TIN	AT62-16-0677	TIN OVER NICKEL OVERALL

SEE PART NUMBER CHART		REF: 1062-16-0622, 1062-16-0644, 1062-16-0677	
QUANTITY	PART NUMBER	DESCRIPTION	ITEM
UNLESS OTHERWISE SPECIFIED			
1) All dimensions are in metric(mm).			
2) Tolerances are as follows:			
1 PL DEC ±0.30			
2 PL DEC ±0.15			
3 PL DEC ±0.08			
Fractions ±1/64			
Angles ±1°			
3) Note reference = $\Delta$			
MATERIAL SPECIFICATIONS:		SIGNATURES	
PROCESS SPECIFICATIONS:		DATE	
NEXT ASSY:		DRAWN: LUCAS CHAI 09/OCT/23	
		CHECKED: ORION LI 10/OCT/23	
		ENGINEER:	
		APPROVAL: TOMMY XIE 12/OCT/23	
		CUSTOMER:	
		THIS DRAWING IS SUPPLIED FOR INFORMATION ONLY. DESIGN FEATURES, SPECIFICATIONS AND PERFORMANCE DATA SHOWN HEREON ARE THE PROPERTY OF THE AMPHENOL CORPORATION. NO RIGHTS OF REPRODUCTION ARE IMPLIED. ALL DIMENSIONS ARE SUBJECT TO NORMAL MANUFACTURING VARIATIONS.	
		<p><b>Amphenol</b></p> <p>Sine Systems - www.amphenol-sine.com          44724 Morley Drive          Clinton Township, MI 48036</p> <p>CONTACT, SOCKET, STAMPED,          SIZE 16, 16-20 AWG, A SERIES</p>	
SIZE	TYPE	DWG NO:	REVISION
B	C-	AT62-16-06XX	A6
SCALE:	NONE		SHEET 1 OF 1

TITLE: SOCKET, STAMPED, SIZE 16, 16-20 AWG, A SERIES  
 DWG NO: AT62-16-06XX  
 REV: A6  
 SH: 1  
 OF: 1